

The Most Trusted name in Pumps & Meters

FILL-RITE.

Series 100 Rotary Hand Pump



Model 100 Rotary Hand Pump Shown
FILL-RITE

Description of Included Models

Model Number	Description	Shipping Weight
110	Basic UL Listed pump with Vacuum Breaker	10 lbs 4.5 kgs
112	Basic UL Listed pump with Vacuum Breaker, 8' Hose & Nozzle, 2" Bung Adapter(1" inlet) and Telescoping suction tube	17 lbs 7.7 kgs
113	Basic UL Listed pump Basic UL Listed pump with 2" Bung Adapter(1" inlet), Telescoping suction tube and Spout	16 lbs 7.3 kgs
114	Basic UL Listed pump with 2" Bung Adapter(1" inlet), Telescoping suction tube, Spout and Drip Pan	18 lbs 8.2 kgs

Safety Listings

Approval Mark	Organization Description	File Number	Guide Number
	Underwriters Laboratories Inc., a nationally recognized independent organization for testing of products to ensure public safety. Recognized and accepted in USA, Canada and other countries	MH6988	EVRZ

Available Options

Option	Description	Shipping Weight (lbs.)	Shipping Weight (kgs.)
113	Rotary pump equipped with Model 111 counter kit.	11.0	4.54
L	Basic unit supplied with liter measure for Series 100	-	-
-X001	Unit supplied less hose	(3.0)	(1.4)
-X002	Unit supplied less telescoping suction tube	(2.0)	(0.9)
-X003	Unit supplied less nozzle	-	-
-X004	Unit supplied less spout	(2.0)	(0.9)
-X005	Unit supplied less hose and nozzle	(3.0)	(1.4)

Accessories

Part Number	Description
5200F1790	Hand pump Nozzle
5200F1619	Discharge spout
5200F1750	Hose - 5/8" X 8' with 3/4" ferrules
100ACC111	Counter kit
100F0842	Barrel bung adapter
400F6634	Wall mount bracket for this pump
100F1189	Telescoping steel suction pipe extends from 22" to 40"
VP172F8617	Suction tube upper section - 17" female to female ends
VP172F6834	Suction tube lower section - 17" male end to 15° cut end
VP62F9091	Steel 1" X 8" nipple to attach suction tube sections to pump
7000KTF7183	Particulate filter kit
7000KTF7186	Hydrosorb filter kit

Performance

Flow Capability	10.3 Ounces (0.306 Liters) per Revolution.
Maximum Dry Vacuum	6" of Mercury
Minimum Lift**	8' of Diesel. For gasoline see below.
Maximum Viscosity of fluid pumped	SAE30 Motor Oil
Maximum ambient operating temperature	150 °F (66 °C)*
Minimum ambient operating temperature	-15 °F (-26 °C)*

* Consult factory for extreme temperature applications outside this range.

** The lift in feet is equivalent to the vertical distance from the surface of the fluid in the tank to the inlet of the pump, PLUS the friction losses through the vertical and horizontal runs of pipe. All elbows and other fittings must be included in the calculation of friction loss. The system should be designed to require a minimum amount of suction lift.

*** Lift of gasoline dependent on Reid's vapor pressure of the gasoline and it's temperature. The lower the vapor pressure and temperature, the higher the possible lift. Refer to the attached Practical Gasoline Suction Lift Considerations to determine the gasoline lift you can expect.

CAUTION: Only pump as clearly carrying the UL Listing Mark should be used with gasoline or any low flashpoint fluid. Look for the Mark.

Fluid Compatibility

The Series 100 Rotary Hand Pumps are designed for petro products of all types. If there is a question for a particular fluid, check the affects of that fluid on the following wetted materials.

Cast Iron Steel Zinc Plated Steel
Acetal Viton® Vellumoid

Also

Nylon-110, 120, 112, and 122 Only

Dimensions

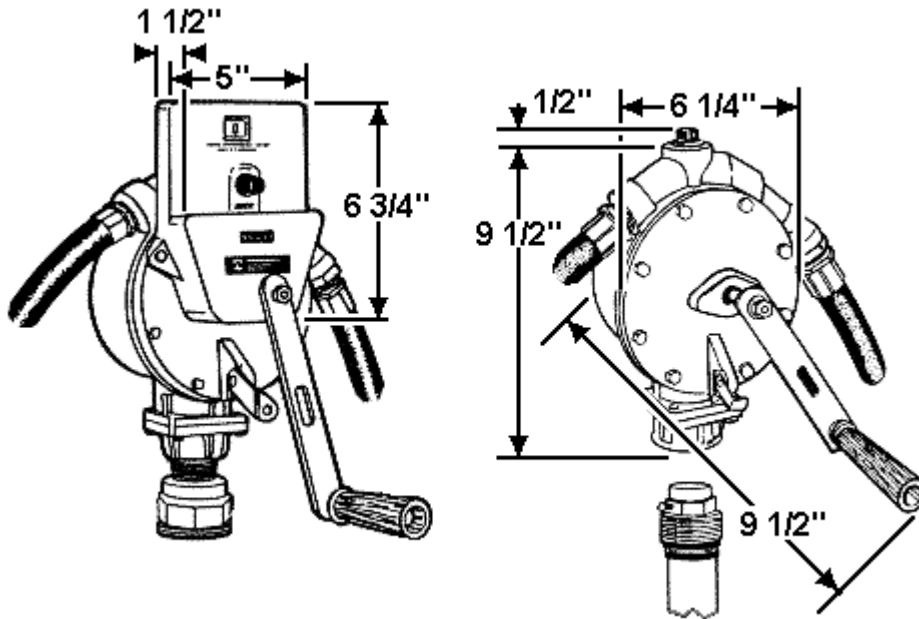

Repair

The Series 100 rotary hand pumps is designed for long years of trouble free service. A number of the more common situations that have been noted are included in the frequently asked questions. If it becomes necessary to take your pump to a service center, always thoroughly flush with a compatible solvent, water for water based fluids and kerosene or diesel fuel for petro products, before packing.

Refer to the Parts and Technical Service Guide packed with the new pump for additional service and repair ideas. A copy of the full guide is included under Reference Documents at the end of this page.

Maintenance

To keep the pump running at its best, periodically perform the following procedures:

1. Thoroughly flush using a compatible solvent, kerosene or diesel fuel, if the pump is to be stored unused for any period of time.
2. if leakage is noted around piston shaft, tighten packing nut in 1/4 turn increments until leakage stops. Over tightening will make pumping more difficult than is necessary.

Frequently Asked Questions

1. My pump is leaking between the cover and the casting. What should I do?

First try tightening the four tie bolts 1/4 turn. Use EXTREME caution as over tightening of these bolts can break the casting. If tightening does not stop the leaking remove the bolts and examine the o-ring in the casting channel and the cylinder edge for damage. A new o-ring may be required. See the parts listing in the Service Guide for the part number of the gasket.

2. The pump capacity is MUCH less than when the pump is new. What's going on?

The pump is either developing much less vacuum than when new, there is an obstruction in the flow path or there is a leakage in the suction causing air to replace liquid. Remove the four bolts attaching the pump body to the inlet flange and remove the pump body. Check to insure the inlet filter screen is not clogged restricting flow. Rotate the handle while holding your palm over the pump inlet, sensing the level of vacuum developed. Little or no vacuum would indicate worn parts preventing the full vacuum from being developed. Install the repair kit F1214 and retest. Significant vacuum would indicate blockage or a leak in the inlet. The blockage or leak must be located and corrected.

3. Fluid is squirting out of the square headed fitting in the pump casting top. How do I stop it?

That "fitting" is the Vacuum Breaker and a critical component of your pumps safety system. Should the hose and nozzle fall on the ground while full of fluid, a siphon action could be established. This could drain the entire tank on which the pump is installed. The Vacuum Breaker is a one way valve which closes when fluid is being pumped. If a vacuum develops in the pump, do to a siphoning action, it allows the entry of air preventing fluid from being drawn out of the tank. If fluid is "squirting" out when pumping, the valve is leaking. Either dirt is preventing the valve from closing or the valve is defective and should be replaced. In either case remove the vacuum breaker and check for dirt or damage. If damaged the vacuum breaker must be replaced with the matching replacement. See your parts manual or the Parts and Technical Service Guide offered under Reference Literature.

4. I have to crank for quite a while before any fluid comes out. What is wrong?

The situation described sounds like a condition normally described as "loss of prime". The check valve is designed to keep fluid in the inlet piping and pump inlet when the pump is not being operated. This insures that fluid flows almost immediately when the pump handle is rotated. If that valve is leaking or there is a leak somewhere in the inlet system, fluid will drain back into the tank., and "prime" will be lost. The valve should be cleaned and carefully examined for proper functioning and/or the leak in the inlet piping located and repaired.

FILL-RITE®

SERIES 100 ROTARY HAND PUMP AND MODEL 111 COUNTER ASSEMBLY

Owner's Operation & Safety Manual Models FR110, FR112, FR113

SAFETY INSTRUCTIONS

To ensure safe and efficient operation, it is essential to read and follow each of these warnings and precautions.

1. Improper use or installation of this product can cause serious bodily injury or death.
2. Do NOT smoke near pump or use pump near an open flame when pumping flammable fluids. Fire could result.
3. A Fill-Rite filter should be used on pump outlet to ensure that no foreign material is transferred to fuel tank.
4. Use gasoline and oil resistant thread sealant or sealant tape on all threaded joints to protect against leakage.
5. Storage tank or barrel should be anchored to prevent tipping in both the full and empty conditions.
6. To minimize static electricity build-up, keep nozzle in contact with container being filled.

WARNING

This product should not be used for fluid transfer into aircraft. This product is not suited for use with fluids for human consumption or fluids containing water.

Fluid Compatibility

If in doubt about compatibility of a specific fluid, contact supplier of fluid to check for any adverse reactions to the wetted materials.

The 100 is compatible with the following fluids:

- Gasoline, Diesel, Heptane, Kerosene, Stoddard Solvent, Light Oils, Mineral Spirits

Do NOT use the 100 with the following fluids:

- Water, Sulfuric Acid, Naptha, Methanol, Methyl Ethyl Ketone (MEK), Acetone, Ammonia, Benzene, Bleach, Chlorine

SAFETY APPROVAL



INSTALLATION

NOTE: All pipe threads must have a sealant to protect against leaks. Use sealant tape provided with the pump, or use a gasoline and oil resistant pipe sealant.

1. Screw suction pipe into pump inlet flange and tighten.
2. Extend suction pipe into tank or barrel opening to within 3" of bottom of tank or barrel. Do not rest suction pipe on bottom.
3. Screw inlet flange of pump completely and securely into undamaged tank or barrel bung.

PUMPS WITH HOSE AND NOZZLE

4. Screw one end of hose into pump discharge opening and the nozzle to other end of hose.

PUMPS WITH DISCHARGE SPOUTS

4. Screw discharge spout assembly into top of pump.

PUMPS WITH METER, HOSE AND NOZZLE

4. Screw street elbow into top of pump, nipple into street elbow, meter onto nipple. Note: Position the meter to the right of the handle facing operator for ease of operator viewing. Screw one end of hose into meter outlet and the nozzle to the other end of hose.

COUNTER INSTALLATION

1. Remove crank from shaft.
2. Remove two screws directly above horizontal centerline of pump.
3. Push drive gear onto shaft with flat in gear hole located on longer flat of shaft.
4. Position counter on pump and attach with two screws and two washers.
5. Reattach crank.

PUMP FLOW REVERSAL INSTRUCTIONS

1. Remove the Vacuum Breaker (item 2) and install a pipe plug.
2. Take out Check Valve Assembly (item 25).
3. Turn the handle backwards for reverse flow, normal direction for normal flow.

TROUBLESHOOTING

IF PUMP FAILS TO PRIME: Check suction line for leaks or obstructions. Check vanes and slots for nicks, burrs or wear. Check rotor for excessive wear or damage.

LOW PUMPING CAPACITY: Remove and clean screen. Check for leaks in suction line. Check rotor and vanes for excessive wear and damage. Check for dirty filter on outlet side.

PUMP FLUID LEAKAGE: Clean O-ring seal and seat area. Replace seal. Replace vacuum breaker. Tighten covers and joints. Check for dirty filter on outlet side.

COUNTER PUMP PARTS LIST

ITM. NO	PART NO.	DESCRIPTION	QTY.
1	100F0890	Counter Back	1
2	100F0900	Dial Wheel	1
3	100F1040	#10L Washer	1
4	100F1050	3/16 Prong-Lock Retainer	1
5	100F1060	Screw PHMS #8 x 3/8 (Type B)	6
6	100F0880	Counter Cover	1
7	100F0910	Dial - 20 Gallon	1
	100F0915	Dial - Liter	Opt.
8	100F1010	Reset Stop Pin	1
9	100F1020	Reset Stop Spring	1
10	704F3811	1/4 Washer	2
11	100F0921	Reset Knob	1
12	100F0960	Totalizer Assembly - U.S. Gallon	1
	100F0961	Totalizer Assembly - Liter	Opt.
13	100F0950	Cluster Gear Shaft	2
14	800F3830	#2S Washer	9
15	100F0940	Cluster Gear (12T/33T) - U.S. Gallon	4
16	100F0970	Drive Gear - Totalizer	1
17	100F0990	Worm (5T) - U.S. Gallon	1
	100F1001	Worm (2T) - Liter	Opt.
18	100F0980	Totalizer Shaft	1
19	100F0930	Drive Gear (41T)	1
	100F0935	Drive Gear (40T) - Liter	Opt.
20	100F1070	1/4-20 x 1 HHMS	2
21	100F0945	Cluster Gear (12T/34T) - Liter	Opt.
22	1200F6565	Washer, Brass	1

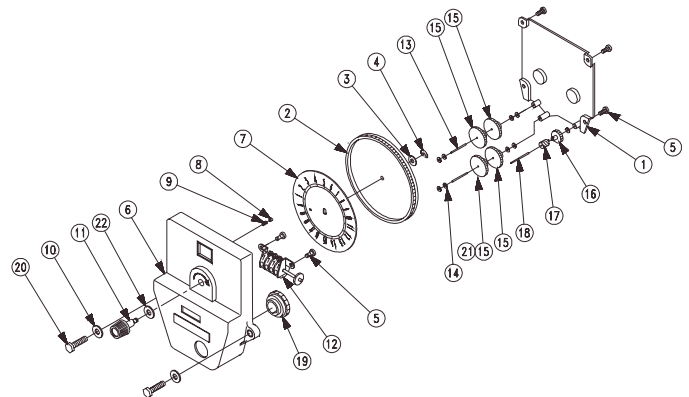

100 SERIES PUMP PARTS LIST

ITM. NO.	PART NO.	DESCRIPTION	QTY.
1	H058G9054	8' Hose - UL Listed	1
2	5200F1869	Vacuum Breaker	1
3	100F0640	Pump Body	1
4	100F0660	Cover	1
5	100F0801	O-Ring (-159)	1
6	100F0701	Shaft	1
7	100F0820	Seal Washer	1
8	100F2062	O-Ring (-114)	1
9	30F4660	Washer	1
10	704F3720	3/8 Lockwasher	1
11	704F3710	3/8-16 Hex Nut	1
12	5200F1360	Bearing Plate	1
13	5200F1410	1/4 x 5/8 Rivet	1
14	5200F1440	1/4 Spring Washer	1
15	100F1180	Locking Link	1
16	100F0680	Rotor	1
17	100F1170	Spring Pin	3

ITM. NO.	PART NO.	DESCRIPTION	QTY.
18	100F0720	Vane Spring	3
19	100F0710	Vane	3
20	30F4540	Crank	1
21	100F1085	Wood Grip	1
22	100F1086	Grip Assy (Includes items 21, 31, 34)	1
23	VP1400F8822	#10-24 x 1/2 TORX PH	2
24	100G8800	1/4-20 x 3/4 HWHTRS	12
25	100F0741	Check Valve Assembly	1
26	100F0790	Inlet Gasket	1
27	100F0760	Screen	1
28	100G9283	Inlet Flange	1
29	5200F1790	Nozzle	1
31	30F5760	5/16-18 Square Nut	1
32	5200F1839	Suction Pipe	1
34	100F1090	5/16-18 x 4 RHMS	1
35	5200F1619	Discharge Spout Assembly	Opt.

**For more information go to www.fillrite.com

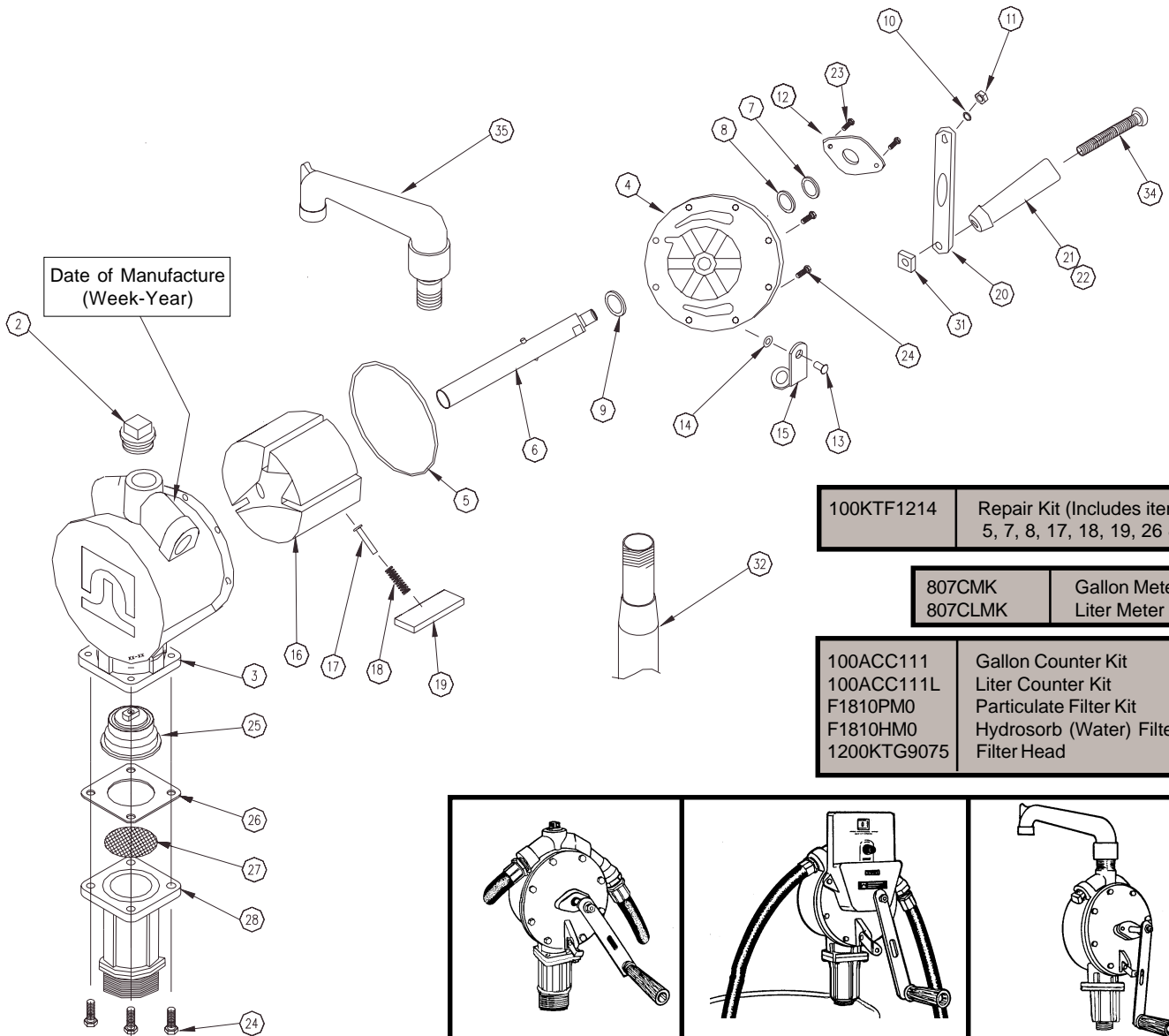

100KTF1214	Repair Kit (Includes items 2, 5, 7, 8, 17, 18, 19, 26 & 27)
------------	---

807CMK	Gallon Meter Kit
807CLMK	Liter Meter Kit

100ACC111	Gallon Counter Kit
100ACC111L	Liter Counter Kit
F1810PM0	Particulate Filter Kit
F1810HM0	Hydrosorb (Water) Filter Kit
1200KTG9075	Filter Head

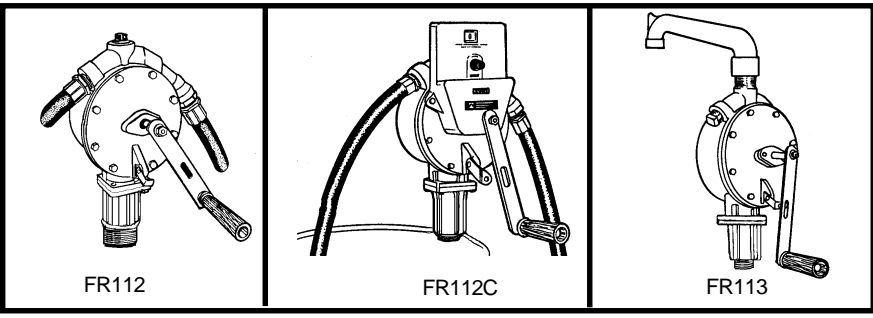

TUTHILL
Transfer Systems

8825 Aviation Drive
Fort Wayne, Indiana USA 46809
Tel 260 747-7524 Fax 260 747-3159

www.tuthill.com

FILL-RITE®

BOMBA DE SERIES 100

Y

CONTADOR DE MODELO 111

Manual de operación y seguridad

Modelos FR110, FR112 & FR113

INSTRUCCIONES DE SEGURIDAD

Para garantizar una operación segura y eficiente, es esencial leer y seguir cada una de las siguientes advertencias y precauciones.

1. El uso o la instalación inapropiadas de este producto podrá causar serias heridas corporales o la muerte.
2. NO FUME cerca de la bomba o use la bomba cerca de llamas cuando esté bombeando líquidos inflamables. Esto podrá resultar en un incendio.
3. Un filtro deberá ser usado en la salida de la bomba para garantizar que ningún material extraño sea transferido al tanque de combustible.
4. Use cinta de Teflón® o sellador de hilos de rosca en todas las articulaciones roscadas con el fin de evitar fugas de fluido.
5. El tanque de almacenamiento deberá estar anclado para prevenir volcaduras, tanto en condiciones de lleno total como en vacío.
6. Para aminorar el aumento constante de electricidad, mantenga boquilla en contacto con el contenedor que se esta llenando.

ADVERTENCIA

Este producto no deberá ser usado para transferir fluidos a un avión. Este producto no es apropiado para usarse con fluidos de consumo humano o con fluidos que contengan agua.

Compatibilidad de fluidos

Si tiene duda sobre la compatibilidad de un fluido específico, póngase en contacto con el proveedor para saber si tiene reacciones adversas con los materiales húmedos mostrados.

La bomba 100 es compatible con los siguientes fluidos:

- Gasolina, diesel, heptano, keroseno disolvente Stoddard, aceites livianos, solventes derivados del petróleo

NO USE la bomba 100 con los siguientes fluidos:

- Agua, ácido sulfúrico, nafta, metanol, metil etil keto (MEK), acetona, amoníaco, bencina, blanqueador, cloro

SEGURIDAD APROBACIÓN



INSTALACIÓN

NOTA: Use un compuesto para tuberías resistente a gasolina y aceite en todos los acoples roscados.

1. Extienda el tubo de aspiración dentro la bomba y apriete.
2. Sitúe la tubería de succión a 3" del fondo del tanque. No descansa la tubería de succión en el fondo.
3. Atornille la brida de entrada de la bomba firmemente al tanque o al tapón del barril.

BOMBAS CON MANGUERA Y BOQUILLA

4. Atornille un extremo de la manguera a la salida de descarga de la bomba y el otro extremo a la boquilla de descarga.

BOMBAS CON DE PICO DE DESCARGA

4. Atornille el ensamble de descarga a la parte superior de la bomba.

BOMBAS CON MEDIDOR, MANGUERA Y BOQUILLA

4. Atornille el codo de descarga en la parte superior de la bomba, el niple al codo de descarga y el medidor al niple. Coloque el medidor de modo que el operador lo pueda ver fácilmente. Atornille uno de los extremos de la manguera a la salida del medidor y el otro extremo de la misma a la boquilla de descarga.

INSTALACIÓN DEL CONTADOR

1. Remueva la manivela del eje.
2. Remueva los dos tornillos ubicados directamente arriba de la línea central horizontal de la bomba.
3. Empuje el engranaje de impulso en el eje con la parte plana en el agujero del engranaje ubicada en la parte plana más larga del eje.
4. Coloque el contador en la bomba y sujételo con dos tornillos y dos arandelas.
5. Reinstale la manivela.

BOMBA EL FLUJO LA INSTRUCCIÓN PARA REVÉS.

1. Remueva el interruptor de vacío y instale un tapón de tubo.
2. Saque el ensamble de válvula de retención.
3. Gire el asidero andar de espaldas para flujo revés, la dirección normal para el flujo normal.

GUÍA DE DIAGNÓSTICO DE PROBLEMAS

No se puede cebar la bomba. Inspeccione las palas y las ranuras para ver si hay desgaste, muescas o dañadas. Apriete tapas y uniones. Revise el rotor y las palas para ver si están palas o del rotor excesivamente desgastadas o dañadas.

Baja capacidad de la bomba. Remueva y limpie el cedazo.

Verifique si hay fugas en la línea de aspiración. Revise el rotor y las palas para ver si están excesivamente desgastadas o dañadas.

Fugas de fluido de la bomba. Limpie la junta tórica y el área del asiento. Reemplace el sello. Reemplace el interruptor de vacío. Apriete tapas y uniones.

ART. NO.	PIEZA NO.	DESCRIPCIÓN	CTD.
1	100F0890	Dorso del Contador	1
2	100F0900	Rueda del cuadrante	1
3	100F1040	Arandela #10L	1
4	100F1050	Retenedor Prong-Lock de 3/16	1
5	100F1060	#8 x 3/8 PHMS (Type B)	6
6	100F0880	Cubierta del contador	1
7	100F0910	Cuadrante - 20 Galones	1
	100F0915	Cuadrante - Litros	Opt.
8	100F1010	Pasador de tope de reinicialización	1
9	100F1020	Resorte de tope de reinicialización	1
10	704F3811	Arandela de 1/4	2
11	100F0921	Botón de reinicialización	1
12	100F0960	Ensamble del totalizador - Galones	1
	100F0961	Ensamble del totalizador - Litros	Opt.
13	100F0950	Eje de agrupamiento de engranajes	2
14	800F3830	Arandela #2S	9
15	100F0940	Engranaje de agrupamiento (12T/33T) - Galones	4
16	100F0970	Engranaje motriz - Totalizador	1
17	100F0990	Engranaje sinfín (5T) - Galones	1
	100F1001	Engranaje sinfín (2T) - Litros	Opt.
18	100F0980	Eje del totalizador	1
19	100F0930	Engranaje motriz (41T)	1
	100F0935	Engranaje motriz (40T) - Litros	Opt.
20	100F1070	Tornillo HHMS de 1/4-20 x 1	2
21	100F0945	Engranaje de agrupamiento (12T/34T) - Litro	Opt.
22	1200F6565	Arandela, Bronce	1

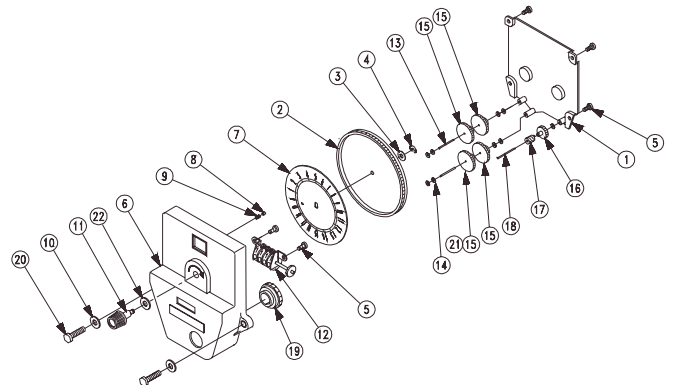

LISTA DE PIEZAS BOMBA DE SERIE 100

ART. NO.	PIEZA NO.	DESCRIPCIÓN	QTY.
1	H058G9054	Manguera Listada UL	1
2	5200F1869	Interruptor de vacío	1
3	100F0640	Cuerpo de la bomba	1
4	100F0660	Tapa	1
5	100F0801	Junta tórica (-159)	1
6	100F0701	Eje	1
7	100F0820	Arandela de sellamiento	1
8	100F2062	Junta tórica (-114)	1
9	30F4660	Arandela	1
10	704F3720	Arandela de seguridad	1
11	704F3710	Tuerca hexagonal de 3/8-16	1
12	5200F1360	Placa del cojinete	1
13	5200F1410	Remache de 1/4 x 5/8	1
14	5200F1440	Arandela resorte de 1/4	1
15	100F1180	Articulación de traba	1
16	100F0680	Rotor	1
17	100F1170	Pasador resorte	3

ART. NO.	PIEZA NO.	DESCRIPCIÓN	QTY.
18	100F0720	Resorte de paleta	3
19	100F0710	Paleta	3
20	30F4540	Manivela	1
21	100F1085	Manija de madera	1
22	100F1086	Ensamble de manija (21, 31, 34)	1
23	VP1400F8822	Tornillo PHMS de #10-24 x 1/2 TORX PH	2
24	100G8800	HWHTRS 1/4-20 x 3/4	12
25	100F0741	Ensamble de válvula de retención	1
26	100F0790	Empaque de entrada	1
27	100F0760	Cedazo	1
28	100G9283	Brida de entrada	1
29	5200F1790	Boquilla	1
31	30F5760	Tuerca cuadrada de 5/16-18	1
32	100F1189	Tubo de aspiración	1
34	100F1090	Tornillo HRMS de 5/16-18	1
35	5200F1619	Ensamble de pico de descarga	Opt.

**Para más información va al www.fillrite.com

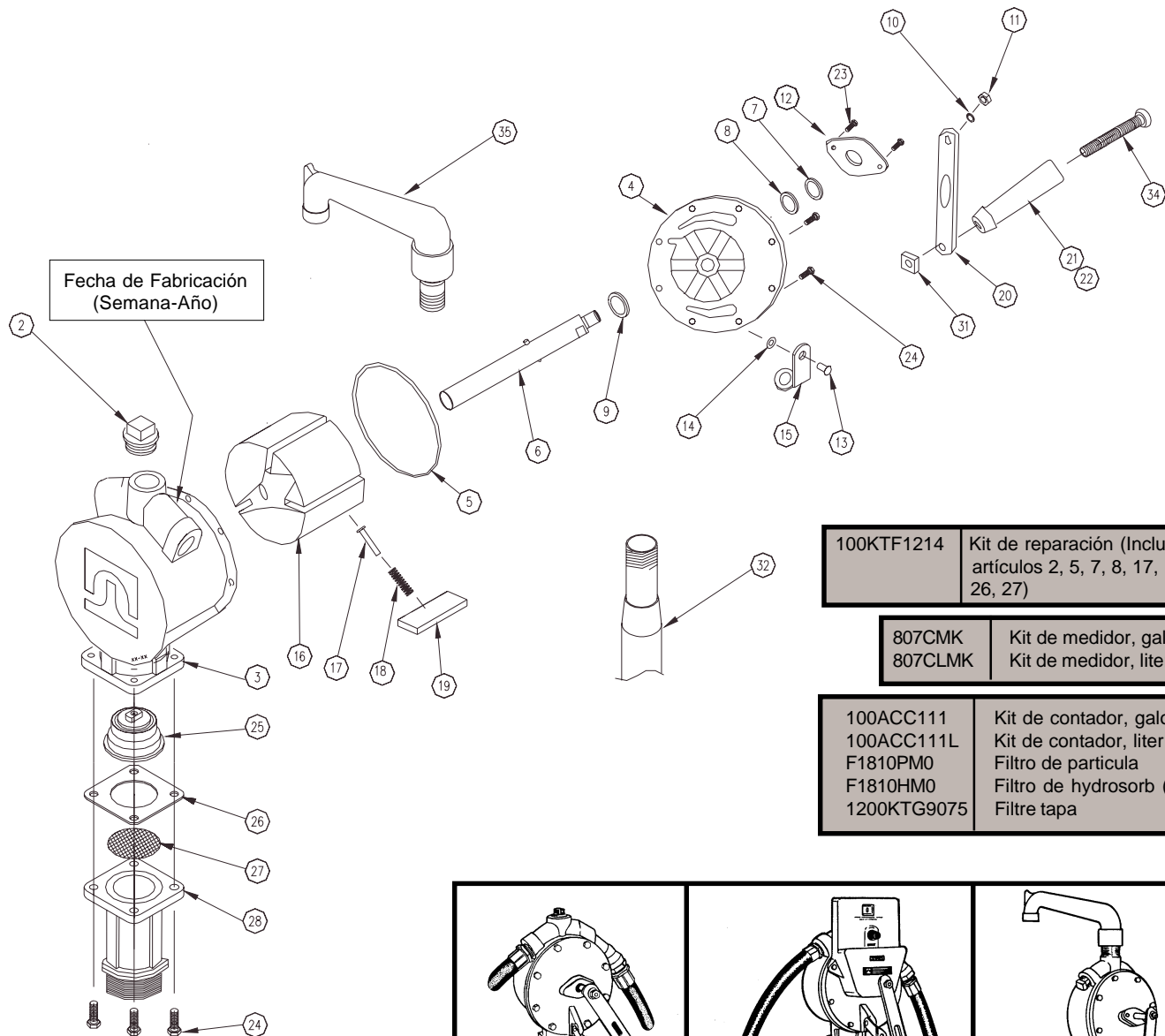

100KTF1214	Kit de reparación (Incluye los artículos 2, 5, 7, 8, 17, 18, 19, 26, 27)
------------	--

807CMK	Kit de medidor, galones
807CLMK	Kit de medidor, liter

100ACC111	Kit de contador, galones
100ACC111L	Kit de contador, liter
F1810PM0	Filtro de partícula
F1810HM0	Filtro de hydrosorb (agua)
1200KTG9075	Filtre tapa

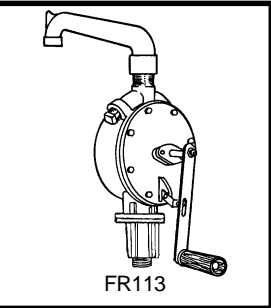
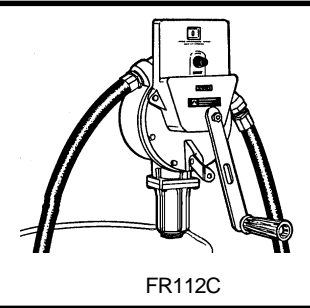
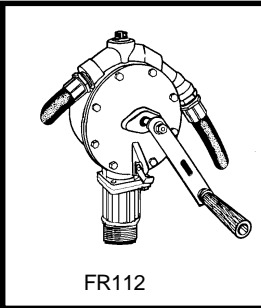

FILL-RITE®

POMPE DE LA SÉRIE 100 LE DÉBITMÈTRE MODÈLE 111

Manual d'utilisation et de sécurité
Modèles FR110, FR111 & FR113

INSTRUCTIONS DE SECURITE

Pour assurer un fonctionnement efficace et sans danger, il est essentiel de lire attentivement tous les avertissements et précautions qui suivent.

1. Une utilisation ou une installation incorrectes de ce produit peuvent entraîner des blessures graves, voire mortelles.
2. Ne fumez PAS près de la pompe et n'utilisez pas la pompe près d'une flamme nue lors du pompage de fluides inflammables. Ceci pourrait entraîner un incendie.
3. Un filtre doit être utilisé sur la sortie de la pompe pour empêcher le transfert de matériau étranger dans le réservoir de carburant.
4. Utilisez du ruban Téflon® ou un enduit d'étanchéité de filet sur tous les raccords filetés pour empêcher les fuites de fluide.
5. La citerne de stockage ou le fût doit être fixé afin d'éviter son basculement qu'il soit vide ou plein.
6. Pour éviter les charges d'électricité statique, veuillez maintenir, lors de la transaction, le bec du pistolet en contact avec le réservoir.

ADVERTENCIA

Ce produit ne doit pas être utilisé pour transférer du fluide dans un avion. Ce produit ne convient pas aux fluides destinés à la consommation humaine ni aux fluides contenant de l'eau.

Compatibilité de fluide

En cas de doute sur la compatibilité d'un fluide spécifique, contactez

le fournisseur du fluide pour connaître les risques de détérioration des matériaux humides indiqués dans la nomenclature.

La 5200 est compatible avec les fluides suivants:

- Essence, diesel, heptane, kérosène, solvant Stoddard, huiles légères, essences minérales

N'utilisez PAS la pompe 5200 avec les fluides suivants :

- Eau, acide sulfurique, naphta, méthanol, méthykéthylcétone, acétone, benzène, eau de Javel, chlore.

SÉCURITÉ



INSTALACIÓN

Utilisez du mastic pour joint de tubes résistant à l'essence et à l'huile sur tous les raccords filetés.

1. Assemblez la conduite d'aspiration.
2. Insérer le tube d'aspiration dans la citerne ou dans le fût en l'ajustant à +/- 7,5cm du fond. Ne pas faire poser le tube d'aspiration sur le fond.
3. Visser complètement au serrage la flange d'aspiration de la pompe dans une citerne ou un fût non endommagé.

POMPE AVEC LE TUYAU ET PISTOLET

4. Visser et serrer un côté du tuyau de service à la sortie de la pompe et l'autre dans le pistolet.

POMPE AVEC ENSEMBLE BEC DE DÉCHARGE

4. Visser l'ensemble de l'embout de service dans le dessus de la pompe.

POMPER AVEC COMPTEUR, TUYAU ET PISTOLET

4. Visser le coude au-dessus de la pompe, le nipple dans le coude et le compteur sur le nipple. Note: positionner le compteur à la droite du levier et faisant face à l'opérateur. Visser un côté du tuyau dans la sortie du compteur et l'autre au pistolet.

INSTALLATION DU DÉBITMÈTRE

1. Déposez la manivelle de l'arbre.
2. Déposez deux vis directement audessus de l'axe horizontal de la pompe.
3. Poussez le pignon moteur sur l'arbre avec le méplat du trou d'engrenage positionné sur le méplat plus long de l'arbre.
4. Positionnez le débitmètre sur la pompe et fixez-le avec deux vis et deux rondelles.
5. Remettez la manivelle en place et fixez-la.

INSTRUCTIONS POUR INVERSER LE SENS DU DÉBIT

1. Retirer l'anti-siphon (item 2) et le remplacer par un bouchon.
2. Retirer l'ensemble clapet (item 25).
3. Tourner le levier dans le sens anti-horlogique pour débit inversé et dans le sens horlogique pour débit normal.

GUIDE DE DÉPANNAGE

La pompe ne s'amorce pas. Recherchez les fuites dans la conduite d'aspiration. Recherchez les encoches, les bavures et les signes d'usure sur les pales et les rainures. Serrez les couvercles et les joints. Recherchez les détériorations et les usures excessives des pales et du rotor.

Faible capacité de la pompe. Problème de conduite d'aspiration - Recherchez les fuites dans la conduite d'aspiration. Recherchez les détériorations et les usures excessives des pales et du rotor.

Fuite de fluide. Nettoyez le joint torique et le siège. Remplacez le joint. Remplacez le reniflard. Serrez les couvercles et les joints.

DÉBITMÈTRE PIÈCES DÉTACHÉES			
NO. ART.	REF. DE PIÈCE	DESCRIPTION	QTÉ.
1	100F0890	Arrière du débitmètre	1
2	100F0900	Roue de cadran	1
3	100F1040	Rondelle 10L	1
4	100F1050	Retenue à griffe 3/16	1
5	100F1060	PHMS #8 x 3/8 (Type B)	6
6	100F0880	Couvercle de débitmètre	1
7	100F0910	Cadran - 20 galons	1
	100F0915	Dial - Litre	Opt.
8	100F1010	Goupille d'arrêt réinitialisation	1
9	100F1020	Ressort d'arrêt réinitialisation	1
10	704F3811	Rondelle 1/4	2
11	100F0921	Bouton de réinitialisation	1
12	100F0960	Totalisateur - galons U.S.	1
	100F0961	Totalisateur - litres	Opt.
13	100F0950	Arbre de train d'engrenage	2
14	800F3830	Rondelle 2S	9
15	100F0940	Train d'engrenage (12T/33T) - gallon	4
16	100F0970	Pignon moteur - totalisateur	1
17	100F0990	Vis sans fin (5T) - galons U. S.	1
	100F1001	Vis sans fin (2T) - litres	Opt.
18	100F0980	Arbre du totalisateur	1
19	100F0930	Pignon moteur (41T)	1
	100F0935	Pignon motieur (40T) - litre	Opt.
20	100F1070	HHMS 1/4-20 x 1	2
21	100F0945	Pignon étagé (12T/34T) - litre	Opt.
22	1200F6565	Rondelle, laiton	1

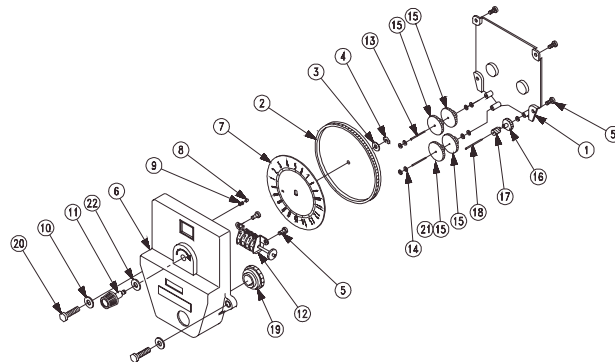

SERIES 100 - LISTE DES PIÈCES DÉTACHÉES

NO ART.	RÉFÉRENCE DE PIÈCE	DESCRIPTION	QTÉ
1	H058G9054	Flexible de 2,4 m (8 pi) – Homologué UL	1
2	5200F1869	Reniflard	1
3	100F0640	Corps de la pompe	1
4	100F0660	Couvercle	1
5	100F0801	Joint torique (-159)	1
6	100F0701	Arbre	1
7	100F0820	Bague d'étanchéité	1
8	100F2062	Joint torique (-114)	1
9	30F4660	Rondelle	1
10	704F3720	Rondelle frein 3/8	1
11	704F3710	Ecrou à six pans 3/8-16	1
12	5200F1360	Plaque de support	1
13	5200F1410	Rivet ¼ x 5/8	1
14	5200F1440	Rondelle ressort ¼	1
15	100F1180	Biellette de verrouillage	1
16	100F0680	Rotor	1
17	100F1170	Goupille à ressort	1

NO ART.	RÉFÉRENCE DE PIÈCE	DESCRIPTION	QTÉ
18	100F0720	Ressort de pale	3
19	100F0710	Pale	3
20	30F4540	Manivelle	1
21	100F1085	Poignée en bois	1
22	100F1086	Poignée (avec articles 21, 31, 34)	1
23	VP1400F8822	PHMS 10-24 x 1/2 TORX PH	2
24	100G8800	HWHTRS 1/4-20 x 3/4	12
25	100F0741	Clapet anti-retour	1
26	100F0790	Joint d'entrée	1
27	100F0760	Crépine	1
28	100G9283	Bride d'admission	1
29	5200F1790	Buse	1
31	30F5760	Écrou carré 5/16 x-18	1
32	100F1189	Conduite d'aspiration	1
34	100F1090	RHMS 5/16-18 x 4	1
35	5200F1619	Bec de décharge	Opt.

**Pour de plus amples renseignements, visiter
www.fillrite.com

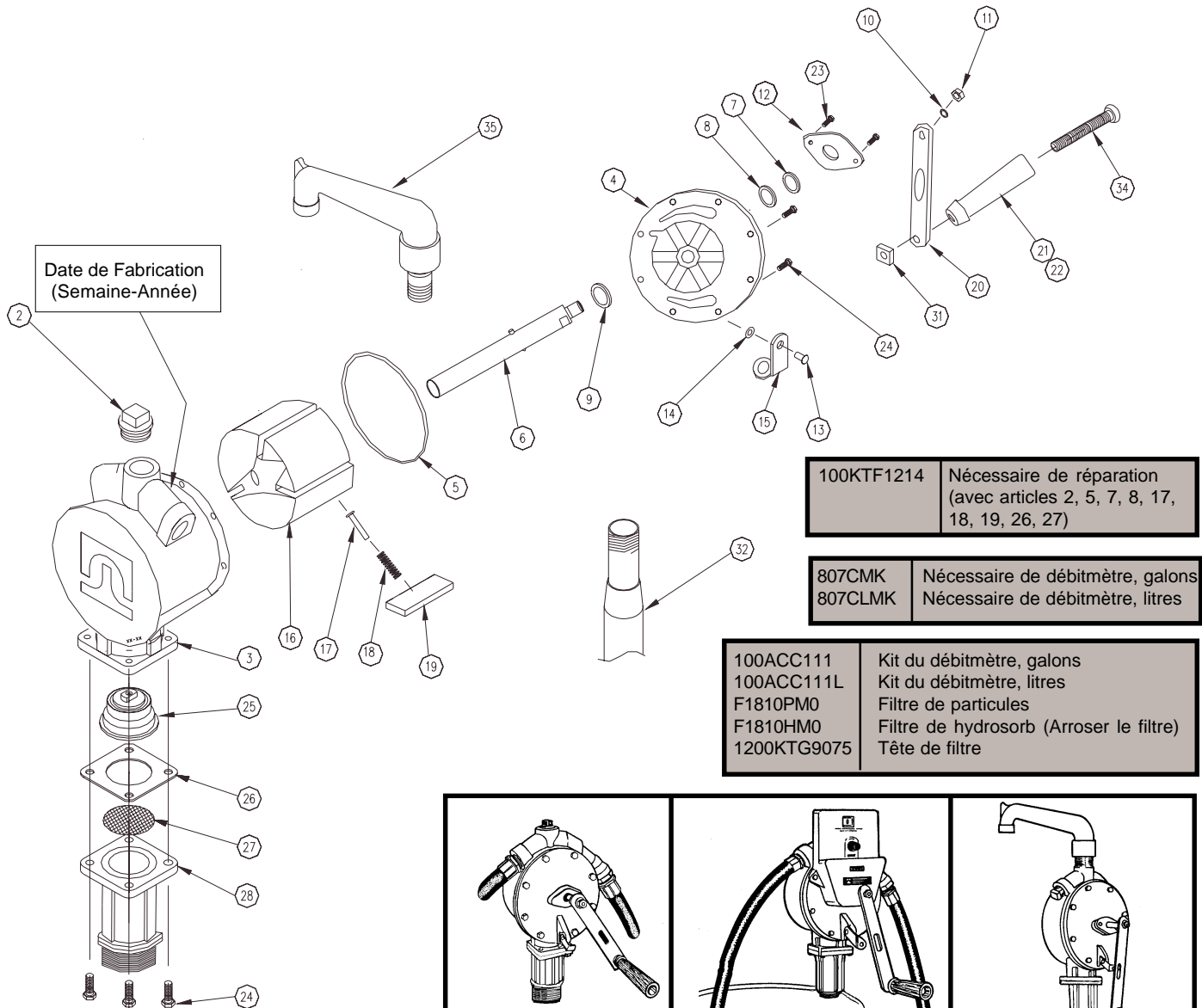

100KTF1214	Nécessaire de réparation (avec articles 2, 5, 7, 8, 17, 18, 19, 26, 27)
------------	---

807CMK	Nécessaire de débitmètre, galons
807CLMK	Nécessaire de débitmètre, litres

100ACC111	Kit du débitmètre, galons
100ACC111L	Kit du débitmètre, litres
F1810PMO	Filtre de particules
F1810HMO	Filtre de hydrosorb (Arroser le filtre)
1200KTG9075	Tête de filtre

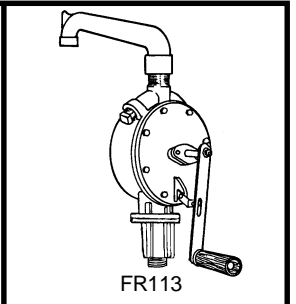
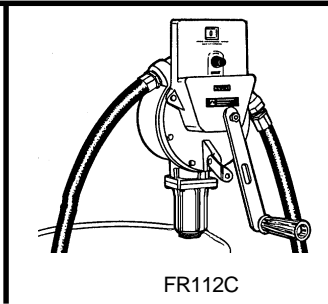
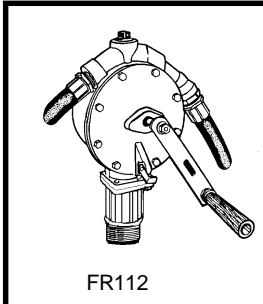

FILL-RITE®

SERIES 100 KREISELPUMPE und MODELL III ZÄHLWERK

Gebrauchsaneisung und Sicherheitsvorschriften Modells FR110, FR112, FR113

SICHERHEITSVORSCHRIFTEN

Für sicheren und leistungsstarken Betrieb die folgenden Warnungen und Vorsichtsmaßnahmen unbedingt beachten.

1. Unvorschriftsmäßige Anwendung oder Installation dieses Produktes kann zu Körperverletzungen oder zum Tod führen.
2. Beim Pumpen brennbarer Flüssigkeiten NICHT rauchen oder Pumpe in der Nähe von offenem Feuer betreiben. Brandgefahr!
3. Den Pumpenauslass mit einem Filter betreiben, damit keine Fremdstoffe in den Brennstofftank gelangen.
4. Alle Schraubverbindungen mit Teflon® Band oder Gewindeabdichtung abdichten.
5. Speichertank oder Faß sollten verankert werden, Neigen in beiden den vollen und leeren Bedingungen zu verhindern.
6. Um eine statische Aufladung zu vermeiden, muss das Zapfventil mit dem zu befüllenden Tank in direktem Kontakt sein.

WARNUNG

Dieses Produkt nicht zur Überführung von Kraftstoff in Flugzeuge benutzen. Produkt eignet sich nicht zum Gebrauch mit für den menschlichen Verzehr vorgesehenen oder Wasser enthaltenden Flüssigkeiten.

Kompatibilität mit Flüssigkeiten

Wenn Zweifel über die Kompatibilität mit einer speziellen Flüssigkeit bestehen, wenden Sie sich an den Hersteller der Flüssigkeit und fragen Sie nach nachteiligen Reaktionen mit den folgenden, in der Stückliste angegebenen benetzten Materialien.

Die 5200 ist mit folgenden Flüssigkeiten kompatibel:

- Benzin, Dieselmotorenöl, Heptane, Kerosin, Stoddard-Solvent, Leichtöle, Spezialbenzin

Die 5200 NICHT mit folgenden Flüssigkeiten benutzen:

- Wasser, Schwefelsäure, Naptha-Benzin, Methanol, MEK, Azeton, Ammoniak, Benzol, Bleichmittel, Chlor

SICHERHEIT



EINBAUANWEISUNG I

Benzin- und ölbeständiges Abdichtungsmittel an allen Schraubverbindungen benutzen.

1. Ansaugrohr zusammensetzen.
2. Dehnen Sie Saugwirkungsrohr in Tank aus oder Faß öffnend zu innerhalb 3" von Boden von Tank oder Faß. Ruhen Sie Saugwirkungsrohr auf Boden nicht.
3. Schrauben Sie Einlaßflansch der Pumpe vollständig und fest in unbeschädigten Tank oder Faß bung.

PUMPEN MIT DÜSE UND SCHLAUCH

4. Schrauben Sie ein Ende des Schlauchs bei der Pumpenentladungsöffnung und die Düse zu anderem Ende des Schlauchs.

PUMPEN MIT ABLAßSTUTZEN

4. Schrauben Sie Entladungsausflussrohrversammlung in Oberteil der Pumpe.

PUMPEN MIT DURCHFLUSSMESSER, SCHLAUCH UND DÜSE

4. Schrauben Sie Straßenellenbogen in Oberteil der Pumpe, Brustwarze in Straßenellenbogen, Meter auf Brustwarze. Stellen Sie Anmerkung: den Meter rechts vom Griff gegenüberstehend Bediener für Bequemlichkeit von Bediener ansehen Ein. Schrauben Sie ein Ende des Schlauchs in Metersteckdose und die Düse zum anderen Ende des Schlauchs.

INSTALLATION DES ZÄHLWERKS

1. Kurbel von der Welle.
2. Die beiden, direkt über der horizontalen Pumpenmittellinie befindlichen Schrauben entfernen.
3. Antriebswerk so auf die Welle drücken, dass die ebene Fläche in der Antriebsöffnung auf der längeren ebenen Fläche der Welle aufliegt.
4. Das Zählwerk entsprechend an der Pumpe ausrichten und mit zwei Schrauben und zwei Unterlegscheiben befestigen.
5. Kurbel wieder anbringen.

ANLEITUNG ZUM ÄNDERN DER DURCHFLUSSRICHTUNG

1. Ersetzen Sie den Herberschutz durch eine Blindkappe.
2. Entfernen Sie das Rückschlagventil.
3. Drehen der Handkurbel entgegen dem Uhrzeigersinn für Rückwärtslauf; Drehen der Handkurbel mit dem Uhrzeigersinn für Normalbetrieb.

BEHEBUNG VON STÖRUNGEN

Pumpe saugt nicht an. Auf Lecks in der Ansaugleitung prüfen. Schieber und Kolben auf Kerben, Unebenheiten oder Abnutzung prüfen. Schraubverbindungen nachziehen. Rotor und Schieber auf Abnutzungserscheinungen überprüfen.

Niedriges Fördervolumen. Sieb herausnehmen und säubern. Auf Lecks in der Ansaugleitung prüfen. Rotor und Schieber auf Abnutzungserscheinungen überprüfen.

Austritt von Pumpenflüssigkeit. O-Ring und Auflagefläche reinigen. Dichtung ersetzen. Anti-Vakuumrückschlagventil ersetzen. Schraubverbindungen nachziehen.

IFD. NR.	PART NO.	BESCHREIBUNG	QTY.
1	100F0890	Rückplatte, Zählwerk	1
2	100F0900	Ring, Skalenscheibe	1
3	100F1040	#10L Unterlegscheibe	1
4	100F1050	3/16 Verschlußring	1
5	100F1060	#8 x 3/8 PHMS (Typ B)	6
6	100F0880	Deckel, Zählwerk	1
7	100F0910	Skalenscheibe - 20 Gallonen	1
	100F0915	Skalenscheibe - Liter	Opt.
8	100F1010	Rückstell-Stopp-Stift	1
9	100F1020	Rückstell-Stopp-Feder	1
10	704F3811	1/4 Zoll Unterlegscheibe	2
11	100F0921	Rückstellknopf	1
12	100F0960	Summierer - U.S. Gallonen	1
	100F0961	Summierer - Liter	Opt.
13	100F0950	Zahnradblockwelle	2
14	800F3830	#2S Unterlegscheibe	9
15	100F0940	Zahnradblock (12T/33T) - U.S. Gallon	4
16	100F0970	Antrieb, Summierer	1
17	100F0990	Schneckenantrieb (5T) - U.S. Gallon	1
	100F1001	Schneckenantrieb (2T) - Liter	Opt.
18	100F0980	Welle, Schneckenantrieb	1
19	100F0930	Antrieb (41T)	1
	100F0935	Antrieb (40T) - Liter	Opt.
20	100F1070	1/4-20 x 1 HHMS	2
21	100F0945	Zahnradblock (12T/34T) - Liter	Opt.
22	1200F6565	Unterlegscheibe, Messing	1

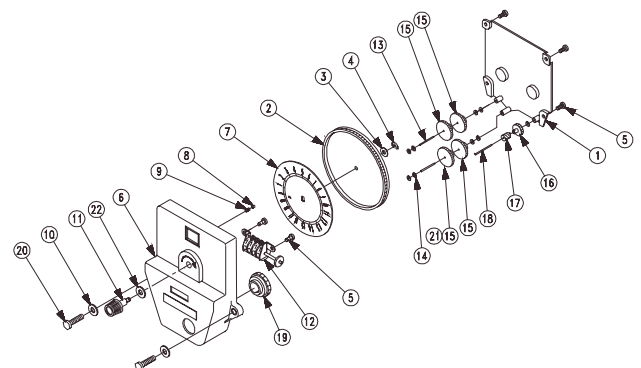

SERIE 100 PUMPE ERSATZLEISTE

IFD. NR.	PART NO.	BESCREIBUNG	QTY.
1	H058G9054	Schlauch, 2,5m, UL-eingetr.	1
2	5200F1869	Anti-Vakuum-Rückschlagventil	1
3	100F0640	Pumpengehäuse	1
4	100F0660	Abdeckung	1
5	100F0801	O-Ring (-159)	1
6	100F0701	Welle	1
7	100F0820	Dichtungsring	1
8	100F2062	O-Ring (-114)	1
9	30F4660	Unterlegscheibe	1
10	704F3720	3/8 Sicherungsscheibe	1
11	704F3710	3/8-16 Sechskantmutter	1
12	5200F1360	Lagerplatte	1
13	5200F1410	Niet, 1/4 x 5/8 Zoll	1
14	5200F1440	Federscheibe, 1/4 Zoll	1
15	100F1180	Verriegelungsglied	1
16	100F0680	Rotor	1
17	100F1170	Federstift	3

IFD. NR.	PART NO.	BESCREIBUNG	QTY.
18	100F0720	Schieberfeder	3
19	100F0710	Schieber	3
20	30F4540	Kurbel	1
21	100F1085	Holzgriff	1
22	100F1086	Griff (einschl. 21, 31, 34)	1
23	VP1400F8822	#10-24 x 1/2 TORX PH	2
24	100G8800	1/4-20 x 3/4 HWHTRS	12
25	100F0741	Sicherheitsventil	1
26	100F0790	Einlassdichtung	1
27	100F0760	Sieb	1
28	100G9283	Einlassflansch	1
29	5200F1790	Düse	1
31	30F5760	5/16-18 Vierkantmutter	1
32	100F1189	Ansaugrohr	1
34	100F1090	5/16-18 x 4 RHMS	1
35	5200F1619	Ablaßstutzen	Opt.

**Für mehr infomationen gehen sie zu www.fillrite.com

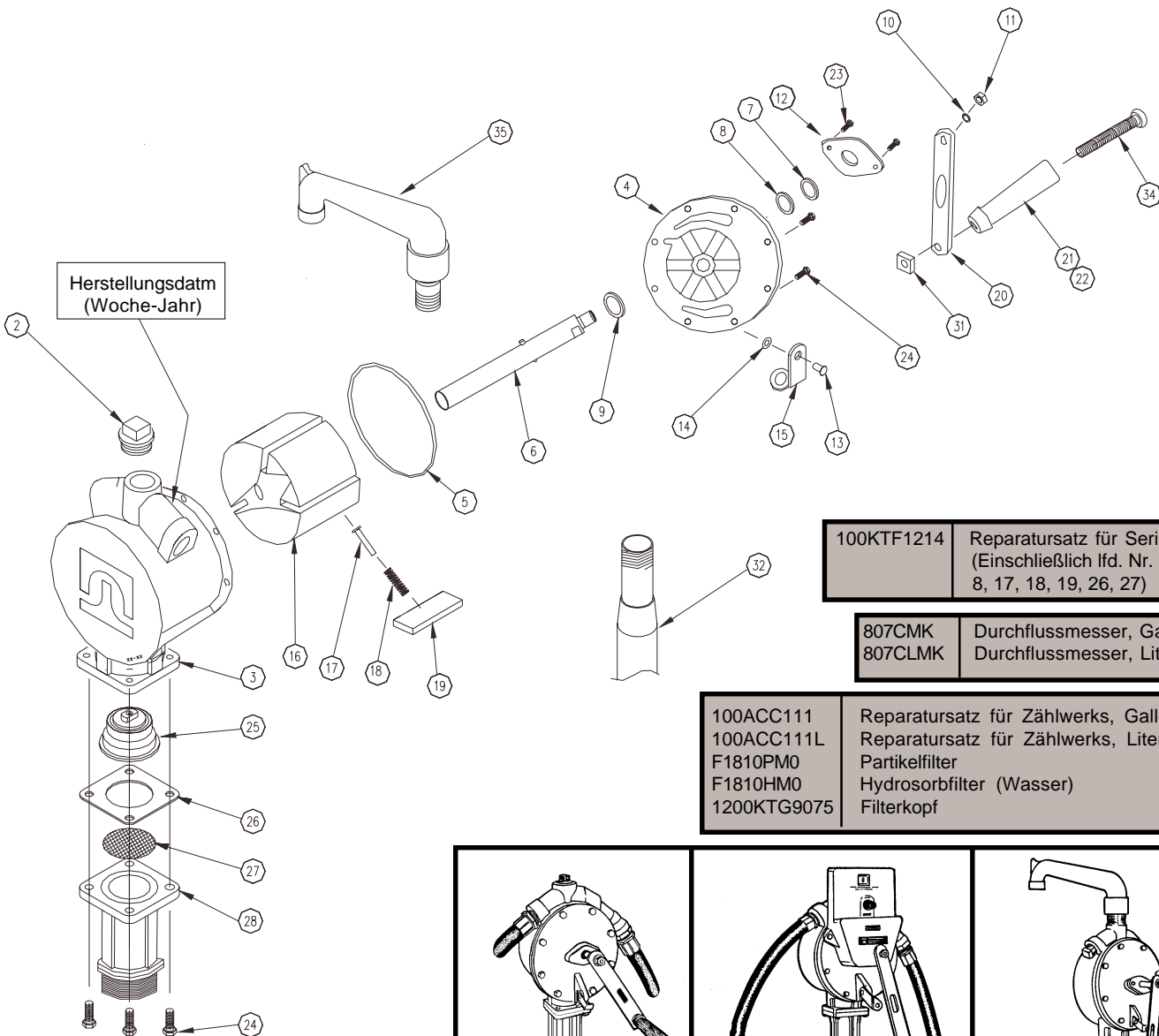

100KTF1214 Reparatursatz für Serie 100
(Einschließlich lfd. Nr. 2, 5, 7,
8, 17, 18, 19, 26, 27)

807CMK Durchflussmesser, Gallonen
807CLMK Durchflussmesser, Liter

100ACC111 Reparatursatz für Zählwerks, Gallonen
100ACC111L Reparatursatz für Zählwerks, Liter
F1810PM0 Partikelfilter
F1810HM0 Hydrosorbfilter (Wasser)
1200KTG9075 Filterkopf

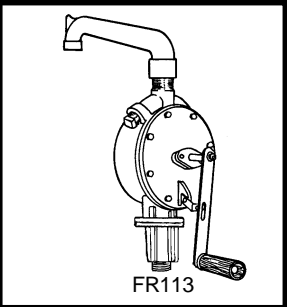
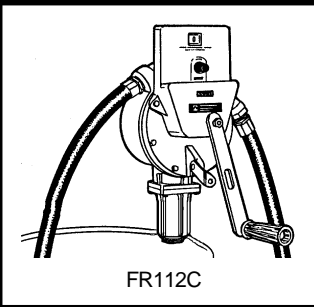
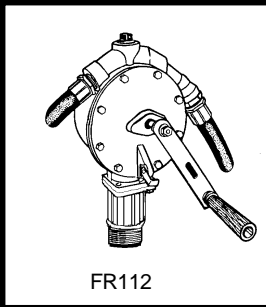

TUTHILL
Transfer Systems

8825 Aviation Drive
Fort Wayne, Indiana USA 46809
Tel 260 747-7524 Fax 260 747-3159

www.tuthill.com