

The Most Trusted name in Pumps & Meters

FILL-RITE.

Series 5200 Piston Hand Pump



Series 5200 Piston Hand Pump Shown
FILL-RITE

Description of Included Models

Model Number	Description	The Change in Shipping Weights
FR150-1	Basic UL Listed pump with Vacuum Breaker	(8 lbs 3.6 kgs)
FR150	Basic UL Listed pump with vacuum breaker, bung adapter, spout and 1" inlet & 3/4" outlet.	(10 lbs 4.5 kgs)
FR151	Basic UL Listed pump with bung adapter, 1" inlet & 3/4" outlet, spout and telescoping suction pipe.	(12 lbs 5.4 kgs)
FR152	Basic UL Listed pump with vacuum breaker, bung adapter, 1" inlet & 3/4" outlet, 8' hose & nozzle and telescoping suction pipe. A kit is available to fit a 807C meter to this model. See kit number 807CMK.	(15 lbs 6.8 kgs)

Safety Listings

Approval Mark	Organization Description	File Number	Guide Number
	Underwriters Laboratories Inc. , a nationally recognized independent organization for testing of products to ensure public safety. Recognized and accepted in USA, Canada and other countries	MH6988	EVRZ

Available Options

Option	Description	Shipping Weight (lbs.)	Shipping Weight (kgs.)
-X001	Unit supplied less hose	(3.0)	(1.4)

-X002	Unit supplied less telescoping suction tube	(2.0)	(0.9)
-X003	Unit supplied less nozzle	-	-
-X004	Unit supplied less spout	(2.0)	(0.9)
-X005	Unit supplied less hose and nozzle	(3.0)	(1.4)

Accessories

Part Number	Description
5200F1593	Barrel bung adapter with square headed screws.
5200F1619	Discharge spout
5200F1750	Hose - 5/8" X 8' with 3/4" ferrules
5200F1790	Hand pump nozzle.
5200F1839	Telescoping steel suction pipe extends from 22" to 40"
807CMK	Model 807C Meter Kit to fit this meter to the FR152 pump.
7000KTF7183	Particulate filter kit
7000KTF7186	Hydrosorb filter kit

Performance

Flow Capacity	20 GPM (76 LPM) at 100 Push/Pull Strokes per Minute
Maximum Recommended Viscosity of Pumped Fluid	Diesel Fuel
Maximum ambient operating temperature	150 °F (66 °C)*
Minimum ambient operating temperature	-15 °F (-26 °C)*
Minimum Dry Vacuum	10 Inches of mercury
Minimum Suction Lift**	11 feet for diesel & see below for gasoline***

* Consult factory for extreme temperature applications outside this range.

** The lift in feet is equivalent to the vertical distance from the surface of the fluid in the tank to the inlet of the pump, PLUS the friction losses through the vertical and horizontal runs of pipe. All elbows and other fittings must be included in the calculation of friction loss. The system should be designed to require a minimum amount of suction lift.

*** Lift of gasoline dependent on Reid's vapor pressure of the gasoline and it's temperature. The lower the vapor pressure and temperature, the higher the possible lift. Refer to the Practical Gasoline Suction Lift Considerations to determine the gasoline lift you can expect.

CAUTION: Only pump clearly carrying the UL Listing Mark should be used with gasoline or any low flashpoint fluid. Look for the Mark.

Fluid Compatibility

The Series 150 piston hand pumps are designed for petro products of all types. If there is a question for a particular fluid, check the affects of that fluid on the following wetted materials.

Zinc Plated Steel

Acetal

Buna N

PPS(2)

Nickel Plated Steel

300S Stainless Steel

Teflon

Viton (3)

Aluminum

400S Stainless Steel

Nylon (1)

(1) All pumps except FR150-1 and FR160-1

(2) FR156, FR159 & FR166 Only

(3) FR156, FR159 & FR166 Only

Dimensions

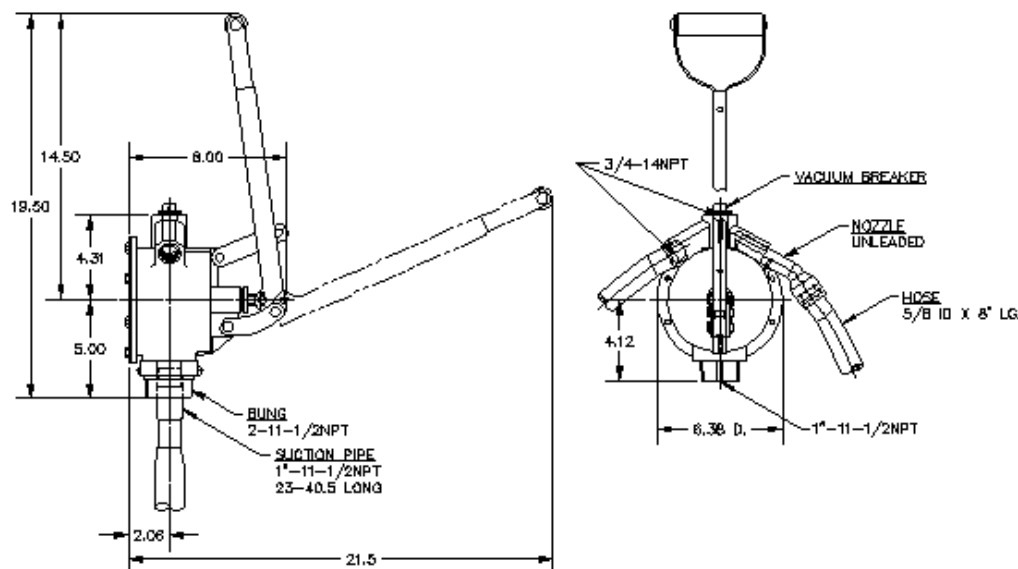

External threads in bung adapter are designed to fit the standard 2" NPT bung found on most barrels and tanks.

Repair

In normal use your Series 5200 pump should never require repair. If your pump stops pumping, check for loss of suction by moving the lever while holding your hand over the inlet opening. Lack of vacuum is usually a result of debris holding one or more of the valves open or clogging the inlet screen. A thorough cleaning will normally restore your pump to full operation.

Leakage around the handle shaft can be corrected by tightening the packing nut. Tighten this nut in 1/4 turn increments to the point where the handle still moves freely but all leakage has stopped.

For other problems it is recommended the pump be thoroughly flushed with diesel fuel, drained and returned to a service center for repair.

Maintenance

To keep the pump running at its best, periodically perform the following procedures:

1. Remove and clean the strainer screen, part number 150-20, after every 20 hours of operation. Cleaning frequency depends on the cleanliness of the fluid being pumped.

Using diesel, thoroughly flush pumps to be stored for an extended period of time.

Frequently Asked Questions

1. I cannot get my pump to prime regardless how fast I pump. How do I fix that?

A failure to prime and/or hold prime is almost always an indication of a leak in the suction tube or piping. Make sure the tube is tightly threaded into the pump inlet and you have used a good grade of teflon® thread tape or thread dope suited to the fluid being pumped. Check all joints carefully.

Another cause could be one or more of the valves being held open by debris, or damage to the valve or valve seat. Thoroughly flushing the pump with clean diesel fuel should clear the debris. Valve or valve seat problems require the pump be disassembled and the defect corrected.

2. My pump capacity is significantly lower than when the pump was new. Anything I can do?

A drop in pump capacity is usually the result of the filter screen becoming progressively clogged with debris. Depending on the fluid being pumped, a periodic disassembly and cleaning would keep your pump operating in a "like new" manner. If the loss in pump capacity is coupled with the pump losing prime, a leak in the suction inlet piping is a definite possibility.

3. When I pump, fluid squirts out of the fitting in the pump top with the holes. How do I stop it?

This "fitting" is the vacuum breaker and is an important safety feature of your pump. Should the hose/nozzle fall on the ground while full of fluid, a siphon action could develop which could drain the contents of your tank onto the ground. It is therefore critical this device be in place and operating properly. The vacuum breaker is designed with a "duck bill" valve so that when a pressure develops within the pump, it closes and prevents fluid from passing out. If a vacuum develops, which would be the case if a siphon was forming, the valve opens and allows air to pass into the pump effectively breaking the siphon action.

If fluid is leaking out of the valve, either debris is holding the duckbill valve open or the valve itself is defective. First carefully clean the valve and if leakage persists, replace the valve with the same type valve. See the next question for ordering information.

4. How do I get parts for my pump?

Refer to the exploded view and parts listing contained in the "Parts and Technical Service Guide" that came packed with your pump or available in the eLibrary. Locate the part or parts needed in the exploded view and use the part "find number" to reference to the part number in the listing. Order that part from your dealer or from the factory.