

PRODUCT DATA SHEET**Series 20 Hand Lever Piston Pump**

- [Description of Included Models](#)
- [Available Options](#)
- [Accessories](#)
- [Performance](#)
- [Fluid Compatibility](#)
- [Dimensions](#)
- [Repair](#)
- [Maintenance](#)
- [Frequently Asked Questions](#)



Model FR20 Shown

Description of Included Models

Model Number	Description
FR20	Basic pump with 360° Locking Ring, Anti-Drip Nozzle, Telescoping Suction Pipe, 2" NPT Bung Adapter, Buna N Seals and Hose Adapter
FR20V	Basic pump with 360° Locking Ring, Anti-Drip Nozzle, Telescoping Suction Pipe, 2" NPT Bung Adapter, Fluorocarbon Seals and Hose Adapter

[\[back to data sheet index\]](#)

Available Options

Option	Description	Shipping Weight (lbs.)	Shipping Weight (kgs.)
B	Buttress Thread 2" Bung Adapter		

[\[back to data sheet index\]](#)

Accessories

Part Number	Description
20F0107	Hose Adapter with Ball Valve
20F0101	3/4" NPT Spout Adapter
20F0481	16" Suction Tube Extension to 51"
20F0495	Hose Adapter with 6' Hose and Nozzle
20F0663	3/4" Hose Adapter

- 30FF1118** Adapter to Use 3/4" NPT Threads
35F0615 2" Buttress Thread Bung Adapter
38F3500 Telescoping Suction Tube Without Check Valve. Fits up to 36" High Container

[\[back to data sheet index\]](#)

Performance

Maximum flow rate	11 Fluid Ounces (325ml) per Stroke
Maximum Viscosity of fluid pumped	Gear Oil (SAE 90)
Maximum ambient operating temperature	150 °F (66 °C)*
Minimum ambient operating temperature	-15 °F (-26 °C)*

* Consult factory for extreme temperature applications outside this range.

[\[back to data sheet index\]](#)

Fluid Compatibility

The versatile and durable Buna N sealed FR20 and fluorocarbon sealed FR20V have been used successfully for transferring engine oil, gear oils, anti-freeze, mild acids and even paraffin. The fluorocarbon seals are offered for the pumping of those methanol and ethanol based solvents that would swell standard Buna N seals.

	<p style="text-align: center;">DANGER</p> <p>Not for use with fluids that have a flash point below 100°F (37.8 °C, ie: gasoline, alcohol). Refer to NFPA 325M (Fire Hazard Properties of Flammable Liquids, Gases and Volatile Solids) for flash points of common liquids. Static electricity buildup and discharge could result in arc and explosion.</p>
---	---

[\[back to data sheet index\]](#)

Dimensions

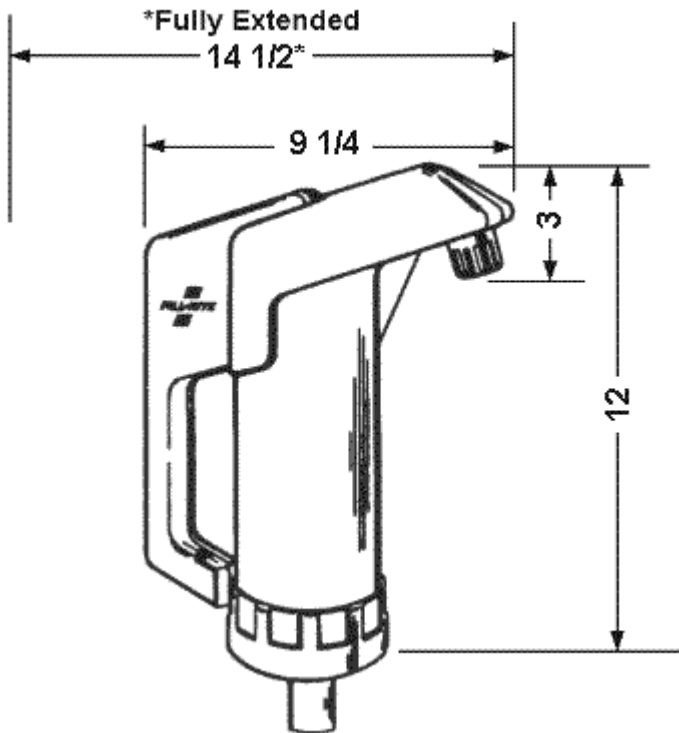

[\[back to data sheet index\]](#)

Repair

Refer to Frequently Asked Questions (FAQ) for possible problems with the pump and suggested correction. Refer to the Parts and Technical Service Guide packed with your pump and available for viewing and printing in the Reference Documents section of this page.

[\[back to data sheet index\]](#)

Maintenance

This pump is designed for years of trouble free service. To maintain the pumping performance at "like new" levels, flush after use with a compatible solvent before extended storage and keep the screen clean.

See meter's Owner's Operation & Safety Manual for its recommended maintenance procedures.

[\[back to data sheet index\]](#)

Frequently Asked Questions

The questions below are linked to the answers for that particular question. Point and click on the question of interest and you will be move to the answer to that question. Buttons are provided to allow you to move back to this question list or to the original INDEX.

1. [My pump loses prime and requires A LOT of pumping before it will pump. What can I do?](#)
2. [The pump's capacity is MUCH lower than when new. How do I correct the problem?](#)

3. [My pump is leaking. How do I stop it?](#)

1. **My pump loses prime and requires ALOT of pumping before it will pump. What can I do?**

Lost prime is almost always caused by an air leak somewhere in the suction tube and/or pump inlet. Remove and reinstall the suction tube using pipe sealing tape. Check the suction tube sliding joint to make sure it is reasonably tight and the gasketing is not damaged.

[\[back to data sheet index\]](#)

[\[back to FAQ's\]](#)

2. **The pump's capacity is MUCH lower than when new. How do I correct the problem?**

The usual culprit is dirt in the screen. A thorough cleaning will usually restore your pump to "like new" performance.

A small leak in the suction tube and/or inlet of the pump will cause air to be drawn in with each stroke and less fluid. If you notice a loss of prime as well this is the likely problem. Always be sure all joints are well sealed and leak free for optimum performance.

Finally if your pump has seen a LOT of hard service, the seals could be worn or damaged, and no longer be sealing properly. Replace the seals and/or the pump.

See the Troubleshooting Guide in your Owner's Manual packed with your unit or the copy available "on-line" in the Reference Documents section of this More Info page for things to check.

[\[back to data sheet index\]](#)

[\[back to FAQ's\]](#)

3. **My pump is leaking. How do I stop it?**

Leaking is most often caused by loose or defective seals or gaskets. The repair is a straight forward tightening or replacement. If the seal or gasket was defective, always insure the seal damage was not a result of a reaction with the fluid being pumped. If it was, the alternate seal material should be considered or the pump not used for that fluid application.

[\[back to data sheet index\]](#)

[\[back to FAQ's\]](#)