

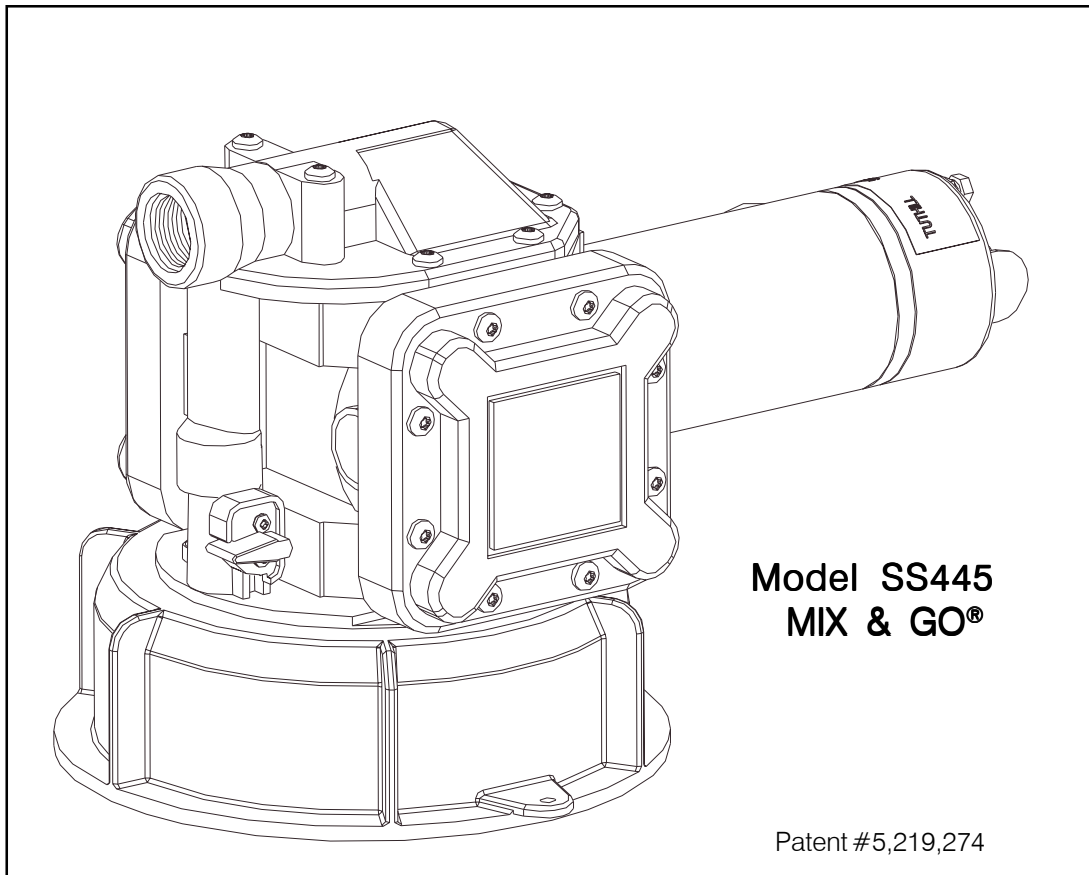

# SERIES 400 DIAPHRAGM PUMP

## FOR AG CHEMICAL FLUID TRANSFER

For Models: 415, 417, 419, 420, 421, 435, 443, 445, 446 (DC)  
460, 460E, 461, 465, 475, 485 (AC)



Dear Sotera Customer,

Thank you for buying a Sotera product. Sotera Systems represents a new age in transfer and measuring equipment. This instruction sheet contains valuable information about your new equipment and its operating and service requirements. Please take a few minutes to review this material carefully.

Sotera Systems' mission is to provide handling systems that deliver the most accurate, safe, convenient and economical transfer systems for users of chemicals.

If, for any reason, any of the products do not meet your performance expectations we want to hear from you. Your comments and suggestions are requested and appreciated. Thank you again for buying a Sotera Systems product. We look forward to serving you in the future.

The Sotera Systems Team  
1-800-796-0614



## DANGER



Electrical wiring should be done by a licensed electrician in accordance with approved electrical codes. Pump should be properly grounded and a rigid conduit should be used when installing electrical wiring. Improper use or installation of this product can cause serious bodily injury or death.



## DANGER

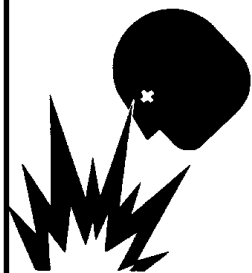

Not for use with fluids that have a flash point below 100°F (37.8°C, ie: gasoline, alcohol). Refer to NFPA 325M (Fire Hazard Properties of Flammable Liquids, Gases, and Volatile Solids) for flash points of common liquids. Static electricity buildup and discharge could result in arc and explosion.



## SAFETY INSTRUCTIONS

1. Use Teflon tape to seal all joints and avoid leakage of fluids being pumped. Leaking of caustic and/or hazardous fluids could result in severe injuries.
2. **Never disassemble YOKE ASSEMBLY (see item 12). This is under extreme pressure and injury could result.**
3. Tank or barrel should be anchored to prevent tipping in both the full and empty conditions.
4. The pump motor is equipped with thermal overload protection. If overheated, it will shut itself off without any damage to the windings. Be sure to turn off the pump power if this occurs. As the motor cools, it will start without warning if power is on.

## GENERAL DESCRIPTION

The Sotera Series 400 is a double action diaphragm pump, using a patented, spring-driven, positive displacement mechanism. The flow rate with low viscosity material is up to 13 GPM. The ultimate in chemical handling capability is provided with stainless steel, polypropylene and fluorocarbon wetted parts.

## OPTIONS

- 1" polypropylene ball valve/nozzle
- Optional hose materials.
- Telescoping polypropylene suction tube
- 825 or 850 electronic digital meter
- 2" NPT or 2" buttnut inlet bung adapter
- 1" FNPT straight and 90° inlet/outlet fittings
- Wraparound tubular mounting frame
- Hastelloy springs
- Tank adapters available for easy installation on most mini-bulk tanks (see price list)
- 12 VDC, 24 VDC, 115 VAC/60 Hz, or 230 VAC/50 Hz motor
- EPDM Seals
- Diaphragm options

## TECHNICAL INFORMATION

### Design Features

- 1" FNPT straight inlet and 90° outlet standard
- 15 PSI maximum outlet pressure
- 2600 RPM, 1/4 HP motor:
  - 12 VDC rated at 20 amps
  - 24 VDC rated at 10 amps
  - 115 VAC/60 Hz rated at 2.0 amps
  - 230 VAC/50 Hz rated at 1.1 amps
- Thermal overload protection of the motor
- 20 ft. long power cable with battery clips (12 volt DC only) and a 30 amp fuse.
- Positive displacement/self-priming design
- Can pass particulate materials up to 0.100" diameter in the pumped fluids
- Flow easily controlled by outlet throttling from maximum to zero
- Pump may run dry without damage
- Handles viscosities from 1.0 CPS to 3700 CPS (ISO 1000wt gear oil at 74°F (23°C))
- Minimum shear (agitation) of pumped fluids
- Does not include inlet strainer
- Minimum operating ambient temperature: -10°F (-23°C)
- Maximum operating ambient temperature: 130°F (54°C)
- Overall dimensions: 14" (35.6 cm) long x 8.25" (21 cm) high x 8.75" (22.2 cm) deep
- Maximum 30 minute duty cycle, not for continuous operation.

### Fluid Compatibility

The 400 Series pump is compatible with the following fluids:

Ammonium Sulfate	** Lumax™
Antifreeze	Malathion
Atrazine 4L®	Methyl Parathion
Banvel®	Motor Oil
Bicep®	Phosphoric Acid
* Camix®	Potash
Caustic Soda (50%)	Princep 4L®
Dual®	Prowl®
Eptam 7E®	Pursuit®
Fultime®	Roundup®
Furadan®	Sodium Hydroxide (50%)
Guardman®	Touchdown®
* Gramoxone Extra®	Transmission Fluid
Harness Xtra®	Zinc + Citric Acid Mix
Hydraulic Oil	Zinc Chloride
Karate®	Zinc Hydrosulfite
Kerosene	Zinc Sulfate
Lasso Micro Tech®	2-4 D

\* Requires Hastelloy Springs  
 \*\*Requires EPDM Seals

The 400 Series pump is NOT compatible with the following fluids:

Very strong acids, any fluid with a flash point below 100°F

If in doubt about compatibility of a specific fluid, contact the supplier of the fluid to check for any adverse reactions to the following wetted materials.

Fluorocarbon	Polypropylene
Santoprene™	300 Series Stainless Steel
Buna-N	

## INSTALLATION

The basic pump is furnished with 1" Female NPT threaded openings in the inlet and outlet flanges. Flanges are available as a straight outlet or a 90° angle design, which can be rotated four ways to accommodate different installation needs. Both inlet and outlet flanges include four 1/4-20 threaded holes, spaced apart 1 7/8" between centers, for secure mounting.

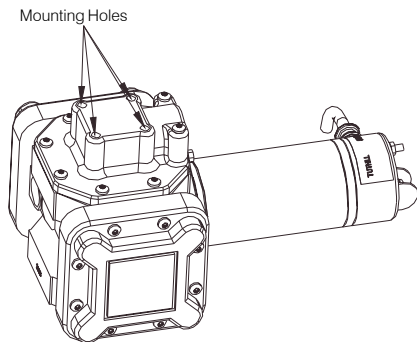

Adapters are available to fit the pump to standard tank fittings common in the petroleum, chemical and agricultural markets. See price sheet for available fittings.

## Electrical Installation

DC ONLY: Connect cable to 12 volt DC power supply as follows, paying special attention to wire colors:

Pump	Cable
Positive	Red
Negative	Black

If pump is to be powered from a vehicle power system it is recommended that permanent wiring and connections be made to vehicle power system which includes a 30 amp slow blow fuse.

**⚠ DANGER**



Electrical wiring should be done by a licensed electrician in accordance with approved electrical codes. Pump should be properly grounded and a rigid conduit should be used when installing electrical wiring. Improper use or installation of this product can cause serious bodily injury or death.

**⚠ DANGER**

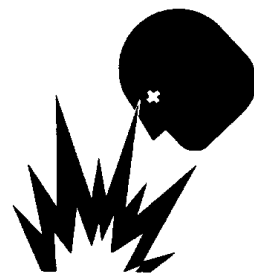

Not for use with fluids that have a flash point below 100°F (37.8°C, ie: gasoline, alcohol). Refer to NFPA 325M (Fire Hazard Properties of Flammable Liquids, Gases, and Volatile Solids) for flash points of common liquids. Static electricity buildup and discharge could result in arc and explosion.

**Circuit Breakers (AC only)** Power to the unit should be supplied from a dedicated 20 amp circuit breaker. No other equipment should be powered from this breaker. Provision must be made to break both legs of any AC circuit.

## CALIBRATION

If a meter is used, calibrate according to the instructions in the meter's Owner's Operation & Safety Manual.

## ASSEMBLY/DISASSEMBLY

**NOTE:** Pump should be thoroughly flushed prior to disassembly.

### Motor/Gear Assembly Removal (Refer to exploded view of pump)

1. If possible, position pump with sight caps down.
2. Remove four screws (item 19) and lift out motor/gear assembly (items 1 and 24).
3. Drain oil from pump if additional maintenance to pump is required.

### Gear Assembly Replacement

1. Remove six screws (item 25) and pull gear assembly from motor.
2. Pull drive gear (item 27) and key (item 28) from motor shaft.

**DO NOT DISASSEMBLE GEAR ASSEMBLY.** Planet gears and ring gear are marked for proper assembly and must not be altered.

### Diaphragm Assembly/ Check Valve Replacement

**NOTE:** Diaphragm and check valve assemblies can be serviced without removing motor and oil from pump body by removing one at a time with diaphragm facing up. Care must be taken not to contaminate oil.

1. Remove motor and drain oil, if complete disassembly is required.
2. Loosen cover (item 4) screws (item 19) slightly and drain fluid trapped in the chamber. Then remove screws and covers.
3. Remove retainer screws (item 11) and o-rings (item 42).
4. Remove diaphragm assemblies (items 7, 8, 9 and 10) by pulling check valves out of pump body, starting with outlet valves first (item 9 at top of pump).
5. Install new diaphragm/check valve assembly, noting ball location in relation to flow. O-rings are on inlet valves at bottom of pump. Lubricate O-rings before inserting into pump body. See Figure #1.

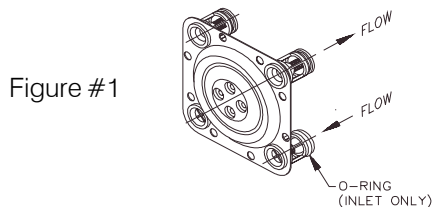

6. Insert four screws (item 11) and o-rings (item 42) into diaphragm as shown and tighten to 50 in. lbs. of torque.
7. Install pump covers (item 4). Hand start and tighten screws to 50 in. lbs.

8. Install motor (item 1) and gear assembly (item 24). Be sure gasket (item 26) is in place. Rotate motor until drive shaft slips in hole in gear assembly. Tighten screws (item 19) to 50 in. lbs. of torque.
9. Fill with approximately 16 ounces of automotive grade SAE 30W oil through one of the holes for sight caps (item 30).

### To further disassemble pump, after step #4 above:

10. Remove four screws (item 19) and lockwashers (item 21) holding bearing plate (item 17).
11. Remove bearing plate (item 17) and thrust plate (item 16).
12. Remove drive shaft (item 13), bearing (item 14), bearing ring (15) and yoke assembly (item 12).

**Assemble in reverse order.** See step #5 through step #9 above for additional assembly instructions. Hand start and tighten screws to 50 in. lbs.

## MAINTENANCE

To keep pump running at its best, periodically perform the following procedures. (Refer to exploded view drawing of pump)

### Chemical Applications

Do not allow chemical to remain in the pump for any extended period of time, whereby the chemicals are allowed to "dry out." Thoroughly rinse pump and meter by flushing the pump with water or appropriate flushing fluid.

**DO NOT USE PRESSURIZED WATER OR PRESSURIZED AIR** to flush your Sotera systems pumps. Damage to the equipment can occur if flush water pressure exceeds 15psi (1 bar). Instead, submerge the suction tube or inlet adapter in clean water and dispense water by operating the pump. Dispose of the flush water properly. After flushing, pump air to remove as much water as possible.

### All Applications on annual basis or as needed.

1. Tighten all external screws to 50 in. lbs. (items 19, 20, & 23).

**NOTE: NEVER EXCEED 50 IN. LB. TORQUE WHEN TIGHTENING SCREWS.**

2. Drain oil through sight caps and replace oil with approximately 16 ounces of automotive grade SAE 30W through one of the sight cap holes. The oil level should be level with the bottom edge of the sight caps (item 30) located on the front of the pump body.

**NOTE:** Always check oil level when the pump is level.

3. Check the four #10-24 x 1/2" machine screws (item 11) holding the diaphragm in place. If loose, tighten screws to 35 in. lbs. to prevent internal leakage.

**NOTE:** If external screws (items 19, 20, & 23) are removed, hand start and tighten to 50 in. lbs.

## REPAIR

**Pumps being returned for service must be triple-rinsed, accompanied by an MSDS sheet indicating the chemicals/fluids which have been pumped and have a current RGA # which can be obtained at (260)747-9060. Pumps not adhering to these specifications may be refused service.**

Apron®, Bicep®, Dividend®, Dual®, Maxim®, and Princep 4L® are registered trademarks of Syngenta Corporation. Broadstrike® and Treflan® are registered trademarks of Dow AgroSciences. DoublePlay®, Eptam 7E®, Fulltime®, Fusion®, Gramaxone Extra®, Karate®, Reflex®, Surpass 100®, and Touchdown® are registered trademarks of Syngenta. Banvel®, Guardsman®, Laddock S-12®, Marksman®, and Rezult® are registered trademarks of BASF. Harness Xtra®, and Roundup® are registered trademarks of Monsanto Company. Prowl®, and Pursuit® are registered trademarks of ABASF. Nufos® is a registered trademark of Cheminova. Assure II® is a registered trademark of DuPont. Furadan® is a registered trademark of FMC.

### Performance

- Maximum of 30 minute duty cycle, not for continuous operation
- 9 inches of mercury dry vacuum
- Suction lift: 10' for water. The lift in feet is equivalent to the vertical distance from the surface of the fluid in the tank to the inlet of the pump, PLUS the friction losses through the vertical and horizontal runs of pipe, all elbows and other fittings. Systems should be designed to require a minimum amount of suction lift.

### SERIES 400 DIAPHRAGM PUMP TYPICAL FLOW RATE FOR VARIOUS VISCOSITIES

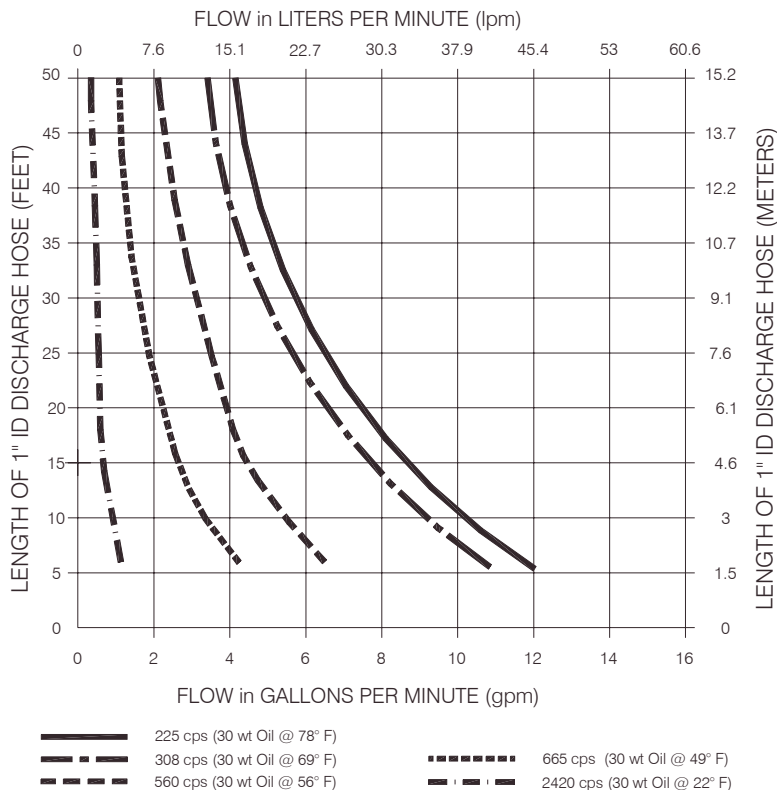

#### NOTES:

- SUCTION LOSSES.**  
Test pump was mounted on a 55 gallon drum of oil, 1/2 full. A SOTERA 1" suction pipe was used.  
A longer or smaller diameter inlet pipe will lower the flow rate.
- VERTICAL HEAD LOSSES.**  
Test hose was horizontal with pump. Add 3 feet of hose for each 1 foot of vertical rise.
- OTHER LOSSES.**  
Elbows, quick-disconnects, swivels, and check valves in outlet or inlet hoses will restrict the flow.  
Add the estimated length of hose for each component used.  
  - 1" SureStop + 0.5 feet
  - Other 1" disconnects + 13.0 feet
  - 1" Check Valves + 8.7 feet
  - 1" Elbow + 2.6 feet

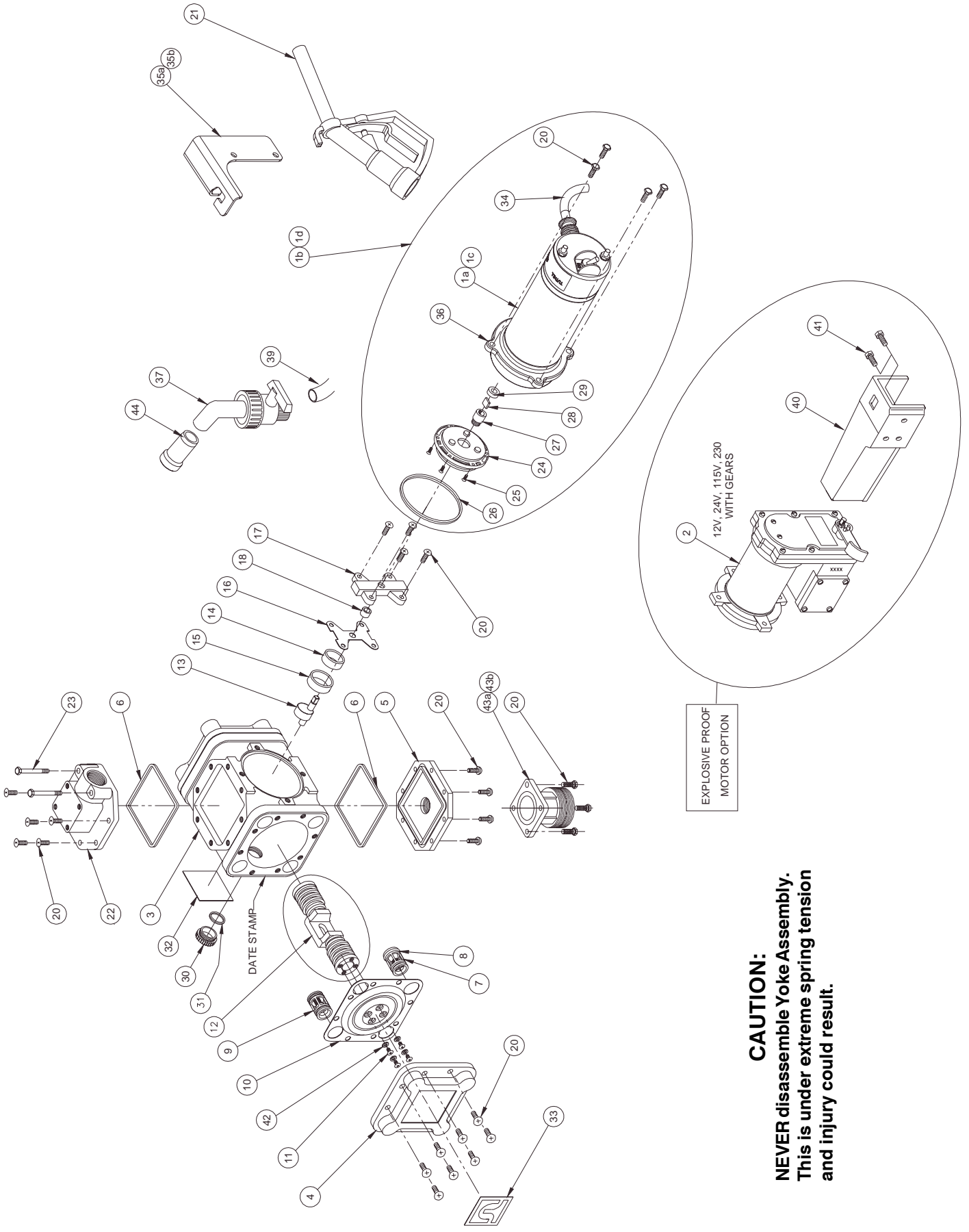

## SERIES 400 PUMP PARTS LIST

ITM. NO.	PART NO.	DESCRIPTION	QTY.
1a	400G9453	12 VDC Motor no gears	1
1b	400G9734	12 VDC Motor with gears	Opt.
1c	400G9486	115 VAC 60 Hz Motor no gears	Opt.
1d	400G9735	115 VAC 60 Hz Motor with gears	Opt.
2a	400F6846	Motor Assembly - 12 VDC EXP PROOF	Opt.
2b	200G7237	Motor Assembly - 24 VDC EXP PROOF	Opt.
2c	400F7351	Motor Assembly - 115 VAC EXP PROOF	Opt.
2d	400G7186	Motor Assembly - 230 VAC EXP PROOF	Opt.
3	400F6567	Pump Body	1
4	400F6568	Pump Cover	2
5	400F6569	Flange, straight	1
6	400F6924	Gasket Inlet Flange	2
7	400F6571	Check Valve - Inlet	4
8	35F6588	O-ring (-117) (Included w/Item 7)	4
9	400F6589	Check Valve - Outlet	4
10	400F6917	Diaphragm Assembly - Santoprene™ (Includes Items 7, 8, 9)	2
11	400F6795	#10-24 x 1/2 THMS	8
12	400F6781	Yoke Assembly	1
13	400F6800	Drive Shaft	1
14	400F6819	Eccentric Bushing	1
15	400F6827	Bearing Ring	1
16	400F6880	Thrust Plate	1
17	400F6579	Bearing Plate	1
18	400F6693	Shaft Bushing	2
20	400F0267	1/4-20 x 3/4 PHMS	30
21	6U100	Nozzle, Aluminum	1
22	400F6679	90° Flange with brass inserts	1
23	400F6817	1/4-20 x 2-1/4 HHMS	2
24	400F6557	Gear Assembly (Included w/Item 1 or 2)	1
25	400G7494	#6-32 x 1/2 FHMS (Incl. w/Item 1 or 2)	6
26	400F6692	Gasket Motor Flange	1
27	400F6563	Drive Gear (Included w/Item 1 or 2)	1
28	1200F6440	Drive Key (Included w/Item 1 or 2)	1
29	400F6707	Shaft Seal (Included w/Item 1 or 2)	1
30	400F6818	Sight Cap, Polypropylene	2
31	400F6813	O-ring (-022)	2
32	400F8517	Nameplate	1
33	400F6758	Logo Plate	2
34	1200F7207	Cable 20 feet (DC Only)	20 FT
35a	400G9736	Nozzle Holder, Aluminum Nozzle	Opt.
35b	400G9737	Nozzle Holder, Poly Nozzle	Opt.
36	400F6566	Gear Housing (Included w/Item 1 or 2)	1
37	400G7006	Ball Valve Nozzle, 1", Poly Nozzle	Opt.
39	700F3123	1" x 12' EPDM Hose	Opt.
	400F3140	1" x 12' Nyal Hose	Opt.
40	700F6748	Nozzle Cover (Explosive Proof motor)	Opt.
41	600F2220	5/16-18 x 3/4 HHCS	Opt.
42	400G8887	O-Ring (007)	8
43a	400G9140	Bung Adapter - NPT	Opt.
43b	400F6528	Bung Adapter - Buttress	Opt.
44	400F0237	Anti-Drip Spout	Opt.
	400F7320	Power Cord (115 VAC Only) (Not Shown)	Opt.
	650G7185	Power Cord (230 VAC Only) (Not Shown)	Opt.
	400F1855	Suction Pipe (Not Shown)	Opt.

**WHEN ORDERING REPAIR PARTS, BE SURE TO GIVE REPLACEMENT PART NUMBER, DATE OF MANUFACTURE AND PUMP MODEL NUMBER. THIS WILL ENSURE THAT THE CORRECT REPLACEMENT PART IS SUPPLIED.**

400KTF6863	Series, 400 Repair Kit (Includes Items 6-11, 24-28, & 42)
------------	--

## TROUBLESHOOTING GUIDE

PROBLEM	POSSIBLE CAUSE	SOLUTION
Pump won't prime	<ul style="list-style-type: none"> <li>• Suction line problem</li> <li>• Leaky check valves</li> <li>• Check valves improperly installed</li> <li>• Outlet plugged</li> <li>• Motor not operating</li>   <li>• Stripped or damaged gears</li> </ul>	<ul style="list-style-type: none"> <li>• Check for leaks in suction line.</li> <li>• Check for dirt or damaged check valves and replace.</li> <li>• Check for proper installation.</li> <li>• Check for blockage and clear.</li> <li>• Check power source.</li> <li>• Repair or replace motor.</li> <li>• Check gear assembly and drive gear for damage. Replace complete assembly if necessary.</li> </ul>
Pump hums but will not rotate	<ul style="list-style-type: none"> <li>• Motor faulty</li> <li>• Gear mechanism jammed</li> </ul>	<ul style="list-style-type: none"> <li>• Replace motor.</li> <li>• Check for free rotation of the gears.</li> </ul>
Low pump capacity	<ul style="list-style-type: none"> <li>• Low voltage</li> <li>• Leaky suction line</li> <li>• Dirt in check valves</li> <li>• Faulty check valves</li> <li>• One or both diaphragms leaking</li> <li>• One piston screw loose</li> <li>• Piston retainer screws loose</li> <li>• Debris ingested</li> </ul>	<ul style="list-style-type: none"> <li>• Check power source.</li> <li>• Repair leaks.</li> <li>• Dismantle and clean.</li> <li>• Install repair kit.</li> <li>• Install repair kit.</li> <li>• Install new yoke assembly.</li> <li>• Install new yoke assembly.</li> <li>• Add inlet screen.</li> </ul>
Motor overheats	<ul style="list-style-type: none"> <li>• Pumping hot fluids</li> <li>• Motor faulty</li> </ul>	<ul style="list-style-type: none"> <li>• Shorten duty cycle.</li> <li>• Replace motor.</li> </ul>
Fluid leakage	<ul style="list-style-type: none"> <li>• Faulty or missing gaskets</li> <li>• Loose bolts</li> <li>• Cracked component</li> </ul>	<ul style="list-style-type: none"> <li>• Install all gaskets specified in parts list.</li> <li>• Torque all bolts to 50 in. lbs.</li> <li>• Replace defective component.</li> </ul>

# Model 445 (DC), 485 (AC)

## MIX & GO®

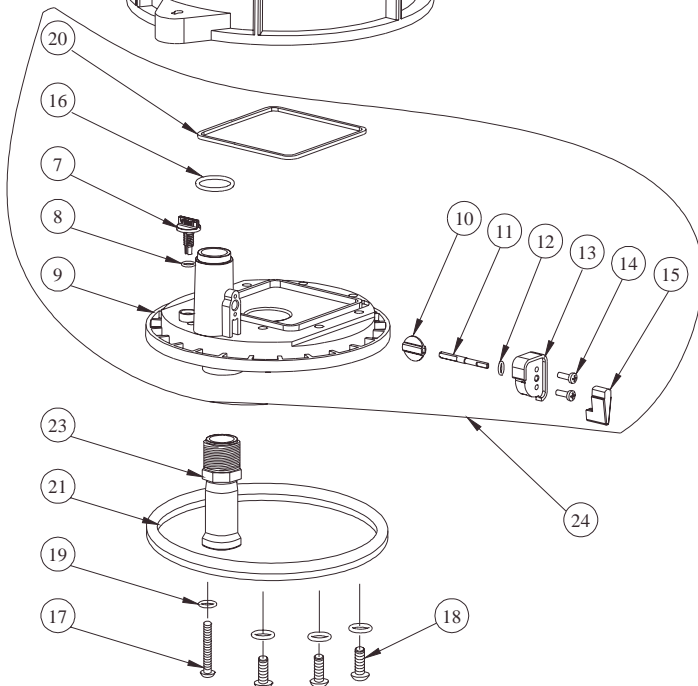
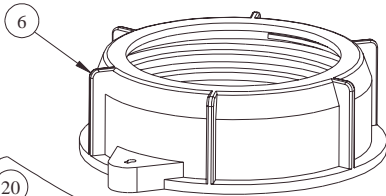
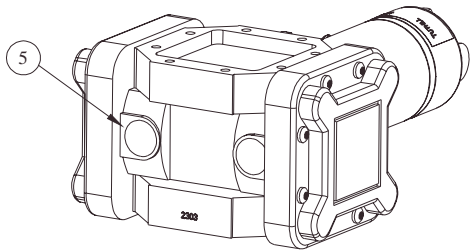
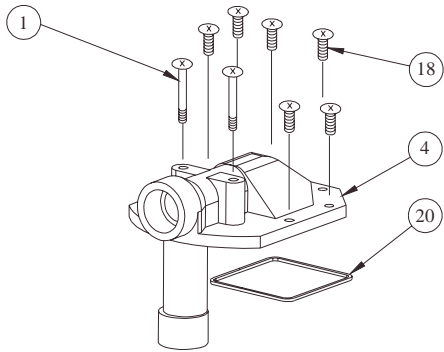
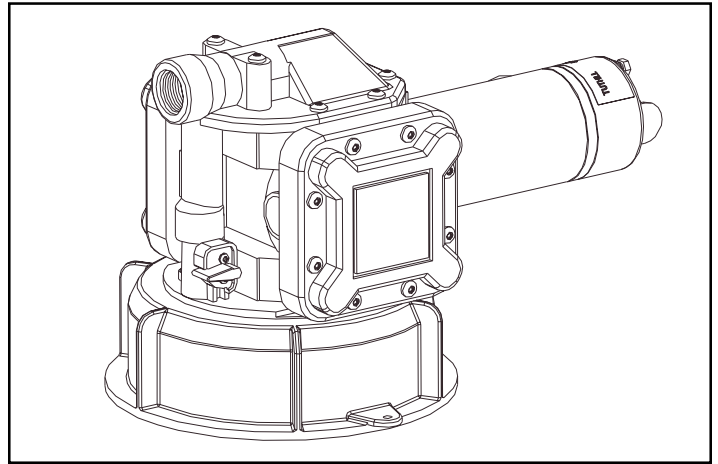

### Parts unique to the SS445 (SS485)

ITM. NO.	PART NO.	DESCRIPTION	QTY.
1	400F6817	1/4-20 x 2 1/2" Bolt	2
3	400F6792	1/4-20 x 3/4" Bolt	6
4	400F0183	Outlet Flange	1
5		Basic Ag Pump 445 DC	1
		Basic Ag Pump 485 AC	opt
6	400F1525	Gem Cap	1
7	445F1634	Vent Assembly with O-Ring	1
8	445F1635	Vent O-Ring (Included w/Item 7)	1
9	445F1587	Inlet Flange	1
10	440F1592	Valve	1
11	445F1609	Shaft	1
12	800F4036	O-Ring	1
13	440F1589	Bushing	1
14	445G9008	Screw	2
15	440F1588	Handle	1
16	442F0214	O-Ring	1
17	445F1610	Long Phillips Screw	2
18	400F0267	Short Phillips Screw	6
19	900F8159	O-Ring	8
20	400F6924	Gasket	2
21	445F1643	Tank Gasket, EPDM	1
23	400F0778	Liquid Recirculation Nozzle Valve	1
24	445G9318	Recirculating Flange Kit	

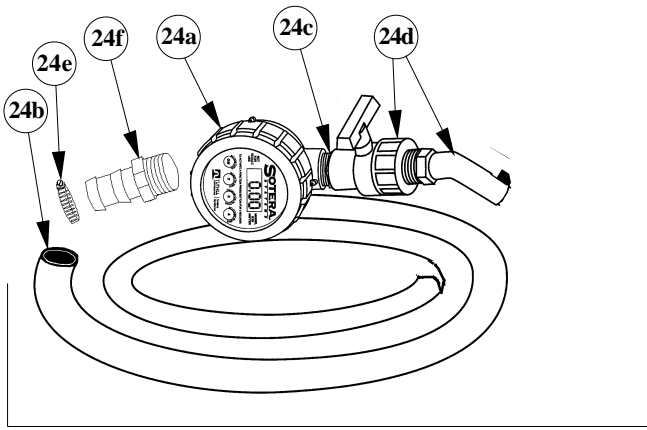

ITM. NO.	PART NO.	DESCRIPTION	QTY.
24a	800F1703	Meter, 825	1
24b	700F3123	1" Hose, EPDM, 12' Long	1
24c	400F3428	1" Nipple	1
24d	400G7006	1" Valve Nozzle Norwesco	1
24e	400F1671	Hose Clamp	2
24f	400F1672	Hose Barb	2
25	445F1863	Suction Tube	1

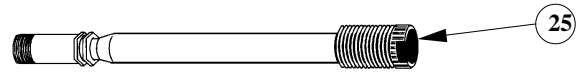

## INSTALLATION

- Using thread sealant, install suction tube (item 25) into the center port of inlet flange (item 9). Use a wrench to firmly tighten suction tube.
- Using thread sealant, install free end of hose (item 24b) into stainless steel elbow (item 22) on pump. Tighten using a wrench.
- Make sure tank gasket (item 21) is attached to the inlet flange (item 9). Place pump on threaded tank opening and screw the Gem Cap (item 6) down until snug. Position the pump as you would like it, then tighten the Gem Cap firmly (item 6) using both hands.

## OPERATING INSTRUCTIONS

### **MIXING:**

Move handle (item 15) so it is pointing down. Shut off ball valve (item 24d). Turn on pump motor switch lever (on back of green motor). Allow system to mix per chemical manufacturer's instructions.

### **DISPENSING:**

#### **Note:**

**Open vent (Item 7) by turning 3 full turns counter-clockwise before dispensing.**

Move handle (item 15) up so it is pointing horizontally away from pump. Turn on pump motor switch lever found on back of motor. Reset meter (item 24a) to 0.00 by holding button (2) for two seconds. Dispense fluid by opening ball valve (item 24d).

Shut off pump motor when complete. Meter will automatically shut off.

**Close vent when finished dispensing by turning clockwise until tight.**

**NOTE:** Consult the 825 Meter Parts and Technical Service Guide for more information.

### **MAINTENANCE/WINTERIZATION:**

Flush pump system with water after use. Dispense a few gallons of water through the pump and meter, as well as through the recirculation spout. After flushing, pump air through the pump and meter to remove as much water as possible.

# SS465 Chemtraveller®

BILL OF MATERIAL			
ITEM NO.	PART NO.	DESCRIPTION	NO. REQ'D
1	400F6892	FRAME-GLOSS BLACK	1
*2	400G7006	1" NORWESCO VALVE/NOZZLE NO TIP	1
3	400F3622	1" POLY BALL VALVE	2
4	400F3428	1" POLY SHORT NIPPLE	1
*5	800F1703	825 METER (SUB)	1
6	435F3457	1" X 14' EPDM DISCHARGE HOSE (RED)	1
7a	400F6728	90° FLANGE	1
7b	400F6679	90° FLANGE W/BRASS INSERTS	1
8	400F6817	1/4" X 2.25" SS BOLT	4
9	400G9156	400 SERIES 110V AC PUMP	1
10	435F3455	1" X 9' EPDM SUCTION HOSE (BLACK)	1
11	39G7046	1" POLY STREET ELBOW / BARB	1
13	400F3618	1" FEMALE COUPLER	1
14			—
15	400F6792	1/4" X 3/4" SS BOLT	4
16	400F3436	1/2" PUSH NUT	2
17	400F3437	WHEEL, 6" X 1.5"	2
18	400F3623	SHAFT, 1/2" DIA. X 19.8" LG.	1
19	400F3438	SPACER	2
20	400F1671	HOSE CLAMP	4
21	400F1672	HOSE BARB ADAPTER, 1"	3

\*NOT INCLUDED IN ALL MODELS

400KTF6867 WHEEL KIT INCLUDES ITEM 16-19

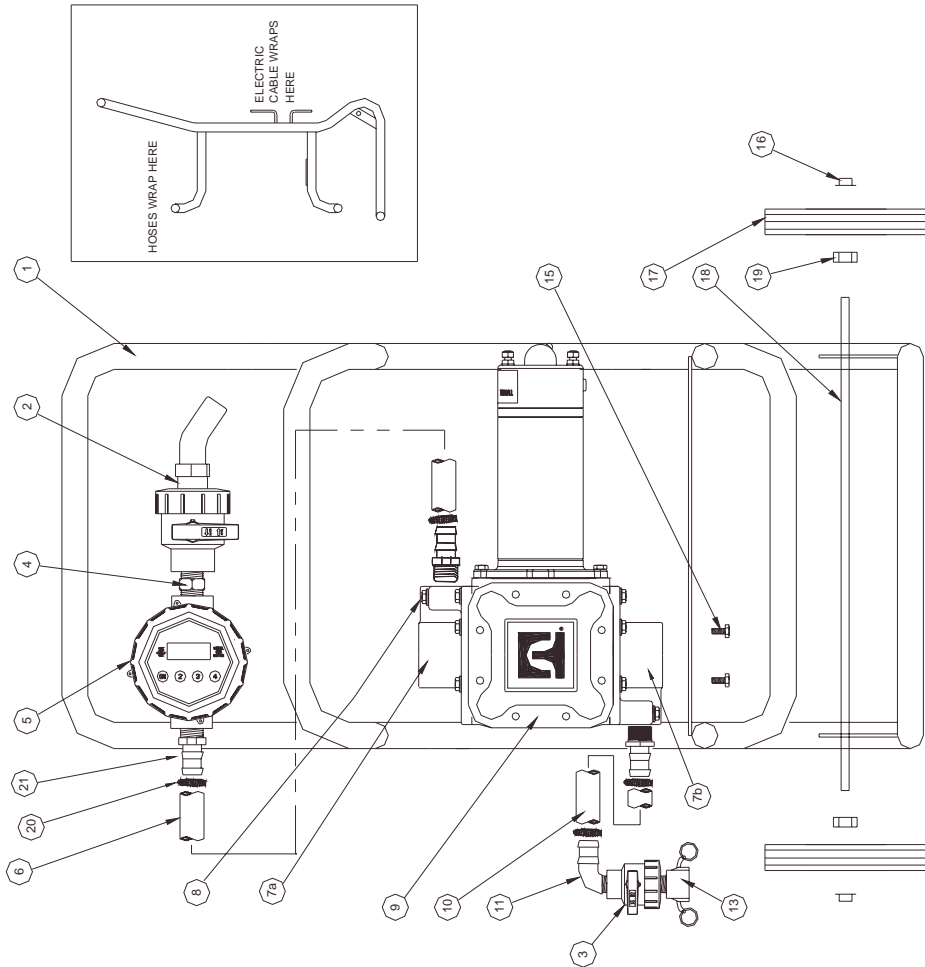

# SS435 Chemtraveller®

BILL OF MATERIAL			
ITEM NO.	PART NO.	DESCRIPTION	NO. REQ'D
1	400F6832	FRAME-GLOSS BLACK	1
*2	400G7006	1" NORWESCO NOZZLE NO TIP	1
3	400F3622	1" POLY BALL VALVE	1
4	400F3428	1" POLY SHORT NIPPLE	1
*5	800F1703	825 METER	1
6a	435F3457	1" X 14' EPDM DISCHARGE HOSE, RED	1
6b	400F3140	1" X 12' NYALL HOSE, BLACK	OPT
7	400F6679	90° FLANGE, BRASS INSERTS	2
8	400F6817	1/4" X 2.25" SS BOLT	4
9a	400F6909	PUMP SUB, 12VDC, SANTOPRENE	1
9b	400G7098	PUMP SUB, 12VDC, SANTOPRENE, SS INSERTS	OPT
9c	400G7163	PUMP SUB, 12VDC, SANTOPRENE, SS INSERTS, HASTELLOY SPRINGS	OPT
10a	435F3455	1" X 9' EPDM SUCTION HOSE, BLACK	1
10b	400F3140	1" X 12' NYALL HOSE, BLACK	OPT
11	39G7046	1" POLY STREET ELBOW / BARB	1
13	400F3618	1" FEMALE COUPLER	1
14	400F2702	12V CABLE ASSEMBLY W/CLIPS	1
15	400F6792	1/4" X 3/4" SS BOLT	4
17	400F1671	HOSE CLAMP	4
18	400F1672	HOSE BARB ADAPTER, 1"	3

\*NOT INCLUDED IN ALL MODELS

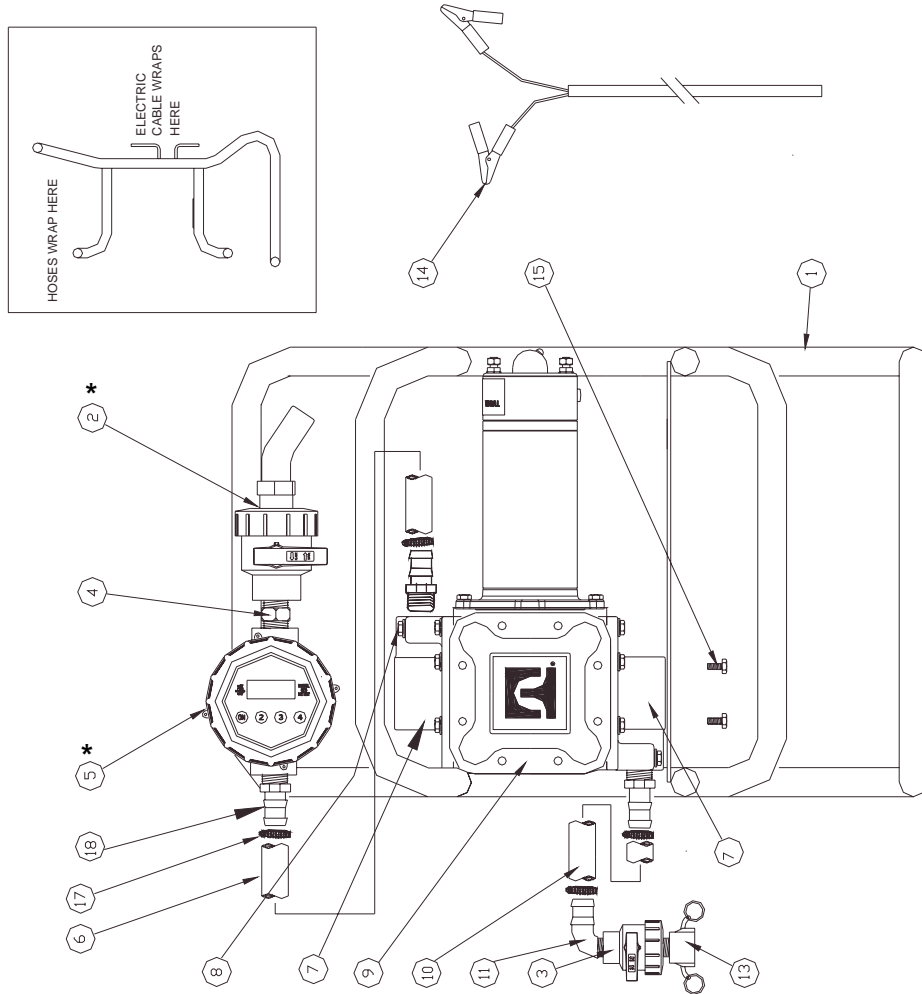

## **MICRO-MATIC DRUM VALVE**

### **Installation Instructions for 435/465 Chemtraveller**

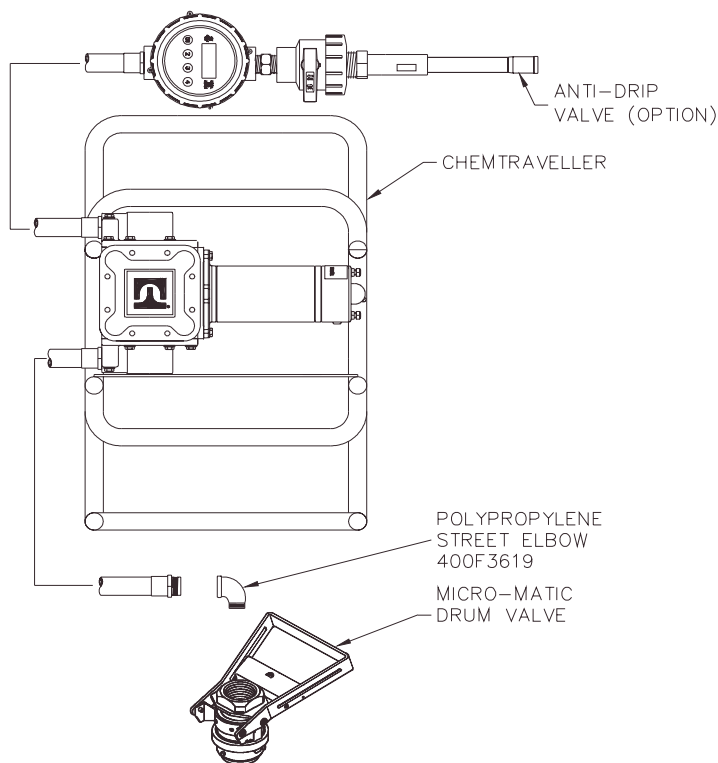

1. Apply thread sealant or Teflon tape to male threads on Chemtraveller suction hose and 90° polypropylene street elbow.
2. Thread elbow onto hose and tighten until snug.
3. Thread drum valve onto elbow. Tighten well.
4. Attach drum valve to container following instructions furnished by Micro-Matic.

## **MICRO-MATIC MACRO VALVE**

### **Installation Instructions for 435/465 Chemtraveller**

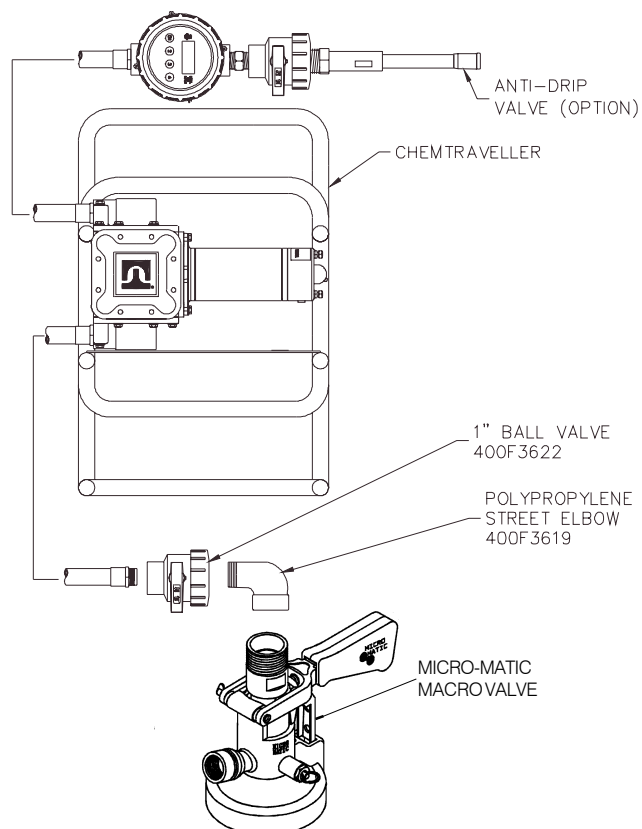

1. Apply thread sealant or Teflon tape to male threads of Macro Valve.
2. Apply thread sealant or Teflon tape to male threads on Chemtraveller suction hose.
3. Thread 1" single union ball valve (F3622) onto suction hose.
4. Apply thread sealant or Teflon tape to male threads of street elbow (F3619) and tighten into ball valve.
5. Thread Macro Valve into street elbow. Tighten until two threads are showing on each connection.
6. Attach Macro Valve to container, following instructions furnished by Micro-Matic.

# Quick Adapter for 2" Bung Kit 400KTG8106 (Included in SS417)

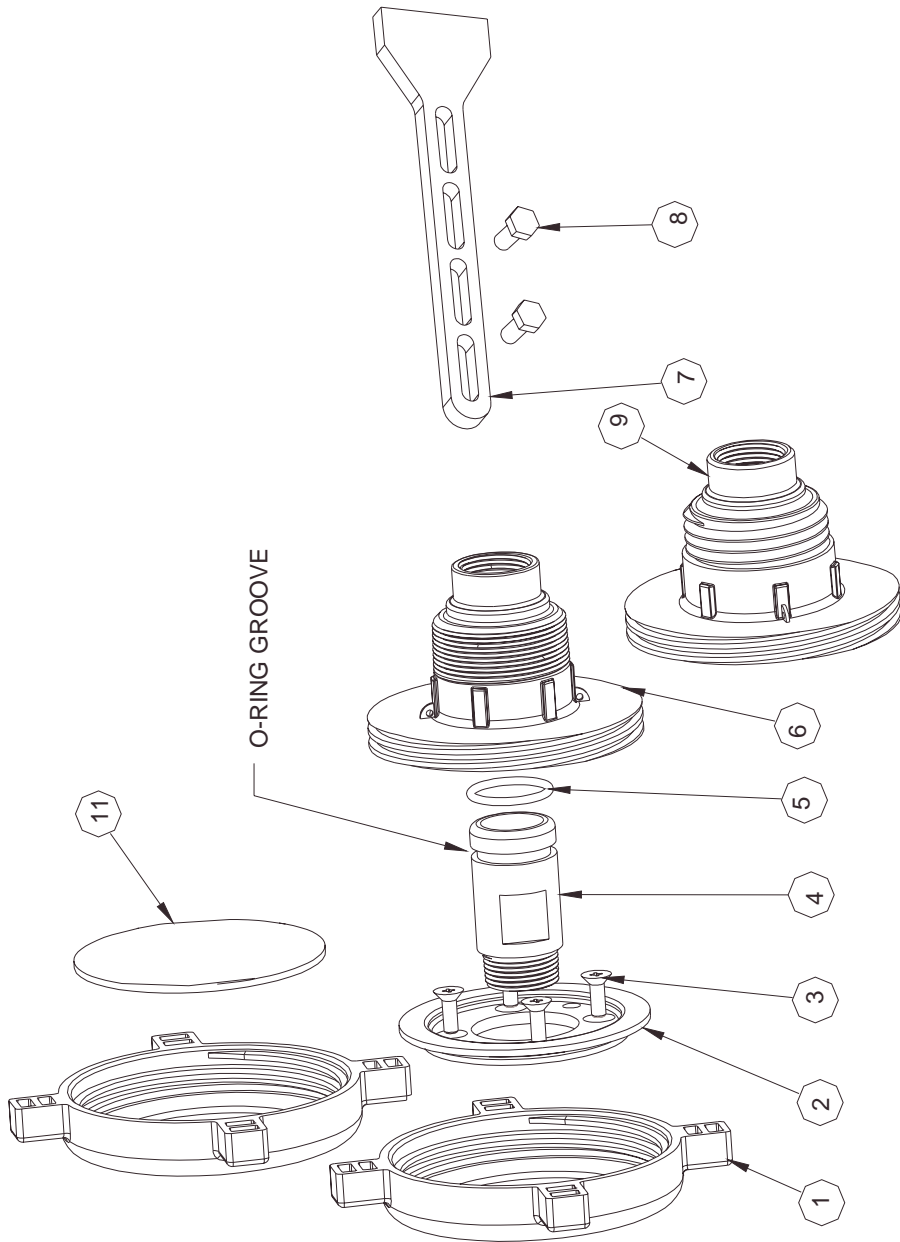

NO.	PART NAME	PART NO.	QTY.
11	DUST CAP	400G8070	1
10	SUCTION TUBE (NOT SHOWN)	400F1855	1
9	BUTTRESS ADAPTER FITTING	400G8069	1 OPT.
8	.312-18 X .875 HHMS	700F2810	2
7	MOTOR SUPPORT	400G8068	1
6	2" NPT ADAPTOR FITTING	400G8064	1 OPT.
5	O-RING 218 VITON	400G8108	1
4	PUMP PROBE	400G8066	1
3	.25-20 X .75 FHMS	400G8081	4
2	PUMP FLANGE	400G8065	1
1	THREADED COLLAR	400G8078	2
	PART NAME		

- 1) Thread NPT Adapter (item 6) or Buttress Adapter (item 9) with suction installed into the 2" tank opening. (Use Teflon tape on suction pipe thread)
- 2) Using Teflon tape, thread Pump Probe (item 4) into the inlet port of the pump. O-ring (item 5) should be in the o-ring groove.
- 3) Lubricate O-ring with Vaseline or oil.
- 4) Attach Motor Support (item 7) to end of motor using 2 hex head screws (item 8).
- 5) Set the pump onto the tank inserting pump probe (item 4) into the adapter on the tank. Tighten Threaded Collar (item 1) firmly.
- 6) Installation of the pump to the tank is completed. The extra Threaded Collar (item 1) and Dust Cap (item 11) are used to protect tank adapter when pump is removed.

**NOTES**

## WELCOME TO A NEW AGE IN LIQUID HANDLING PRODUCTS.

With the creation of Sotera Systems, Tuthill Corporation has ushered in a new age in liquid handling products for transferring chemicals. After more than 35 years of product research and development in fuel and chemical handling equipment, Tuthill Corporation created Sotera Systems to focus solely on the needs of the chemical user.

You'll recognize the familiar Tuthill traits in every Sotera Systems product, like uncompromised quality, workmanship and dependability. Sotera Systems is something more, something unique. Our products are designed, engineered, tested and serviced by Chemical Industry people, who understand the needs for handling chemicals, the changes that are taking place, and the liquid handling solutions it will take to meet those needs.

## A SPECIAL MARKET PLACE. A SPECIAL COMPANY.

The chemical handling market is a dynamic, ever-changing world and Sotera Systems people are talking to chemical users of all kinds, and listening to what they have to say.

And they are concerned about safety, accuracy, governmental policies, convenience, cost and dependability. By being in the areas where chemicals are used, Sotera Systems gains tremendous insight into the needs of manufacturers and end users. We use this information to create products that make sense for that market. It takes a dedicated company to grasp every detail and translate it into products that perform. It takes a company like Sotera Systems.

## CHEMICAL INDUSTRY PRODUCTS. CHEMICAL INDUSTRY SUPPORT.

Day in and day out, our attention and commitment is to the chemical transfer market. This commitment goes beyond the manufacturing of quality equipment; it includes world-wide product support and technical expertise. Our distributors and dealers are professionals who offer years of experience in the latest handling devices for chemical products. Our mission is to lead the way in finding transfer systems that are safe, accurate, convenient and economical. In partnership with our customers, Sotera Systems is championing a new era of handling systems for all Chemical Transfer applications.

## PRODUCT WARRANTY

Sotera Systems of Tuthill Corporation ("Manufacturer") warrants to each buyer of its products ("the Buyer") for a period of 12 months from date of invoice or sales receipt but in no event more than 18 months from date of manufacture that goods of its manufacture ("Goods") will be free from defects of material and workmanship. Manufacturer's sole obligation under the foregoing warranties will be limited to either, at Manufacturers' option, replacing or repairing defective Goods (subject to limitations hereinafter provided) or refunding the purchase price for such Goods theretofore paid by the Buyer, and Buyer's exclusive remedy for breach of any such warranties will be enforcement of such obligations of Manufacturer. If Manufacturer so requests the return of the Goods, the Goods will be redelivered to Manufacturer in accordance with Manufacturer's instructions F.O.B. Factory. The remedies contained herein shall constitute the sole recourse of the Buyer against Manufacturer for breach of warranty. IN NO EVENT SHALL MANUFACTURING BE LIABLE FOR CONSEQUENTIAL DAMAGES NOR SHALL MANUFACTURER'S

LIABILITY ON ANY CLAIM FOR DAMAGES ARISING OUT OF THE MANUFACTURE, SALE, DELIVERY OR USE OF THE GOODS EXCEED THE PURCHASE PRICE OF THE GOODS. The foregoing warranties will not extend to Goods subjected to misuse, neglect, accident or improper installation or maintenance, or which have been altered or repaired by anyone other than Manufacturer or its authorized representative. THE FOREGOING WARRANTIES ARE EXCLUSIVE AND IN LIEU OF ALL OTHER WARRANTIES OF MERCHANTABILITY, FITNESS FOR PURPOSE OF ANY OTHER TYPE, WHETHER EXPRESS OR IMPLIED. No person may vary the foregoing warranties and remedies except in writing signed by a duly authorized officer of Manufacturer. Warranties or remedies that differ from the foregoing shall not otherwise be binding on Manufacturer. The Buyer's acceptance of delivery of the Goods constitutes acceptance of the foregoing warranties and remedies, and all conditions and limitations thereof.



8825 Aviation Drive  
Fort Wayne, Indiana USA 46809  
Tel 260 747-9060 Fax 260 747-3934



2000 Glades Road, Suite 206  
Boca Raton, Florida USA 33431  
Tel 561 447-8190 Fax 561 447-8197



Parc Industriel Wavre Nord-Avenue Vésale 30  
B-1300 Wavre Belgium  
Tel 32-10/22.83.34 Fax 32-10/22.83.38