

JABSCO® PUMPS

Self - Priming Pumps

MODEL:12050-0001

Product Data
For Chris Craft 283 Series
V-8 Marine Engine

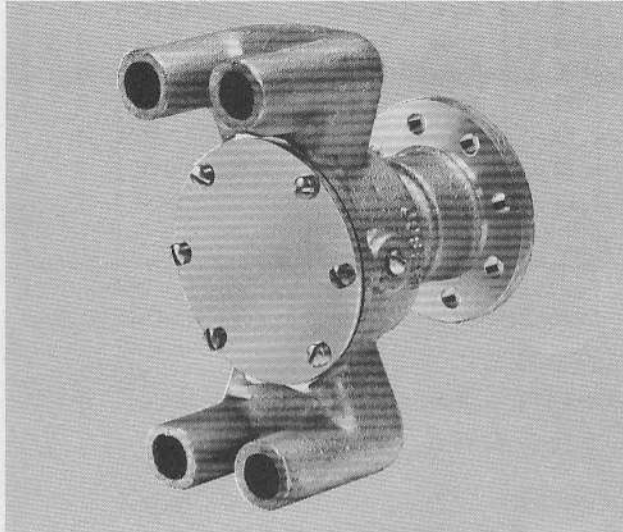

DESIGN FEATURES

Body:	Bronze Construction
Impeller:	Jabco Neoprene Compound
Shaft:	Brass
Wearplate:	Replaceable
Shaft Seal:	Mechanical Face Type
Ports:	3/4" Dual Discharge (Hose Connection) 3/4" Dual Inlet (Hose Connection)
Weight:	4 lbs. (approximately)

MODEL 12050-0001

OPERATING INSTRUCTIONS

INSTALLATION - When pump rotation is clockwise (facing endcover), install with cam screw away from engine. When pump rotation is counter clockwise (facing endcover), install with cam screw toward engine. Lower ports will be inlet. Pump may be positioned (using extra holes in mounting flange) to clear engine beds or equipment around pump.

SELF-PRIMING - Primes at low or high speeds. Be sure suction line are air-tight or pump will not self prime.

RUNNING DRY - Unit depends on liquid pumped for lubrication. **DO NOT RUN DRY** for more than 30 seconds. Lack of liquid will burn the impeller.

TEMPERATURES - Standard impeller is designed to handle liquid temperatures between 45°-180° F.

FREEZING WEATHER - Drain unit by loosening the end cover. The following anti-freeze compounds can be used without any adverse effects to the impeller: Atlas "Permaguard", DuPont "Zerex" and "Telar", Dow Chemical "Dowguard" and Olin Mathison "Pyro". Most methyl alcohol (methanol) based anti-freeze can be used. **DO NOT USE PETROLEUM BASED ANTI-FREEZE COMPOUNDS OR RUST INHIBITORS.**

GASKET - Use standard pump part. Thicker gasket will reduce priming ability. A thinner gasket will cause impeller to bind.

SPARE PARTS - A JABSCO Service Kit SK-117 should be kept on hand to service all but the most badly worn 12050-0001 pump.

JABSCO PRODUCTS ITT

Form 43000-0201 Rev. 5-76

CROSS SECTION

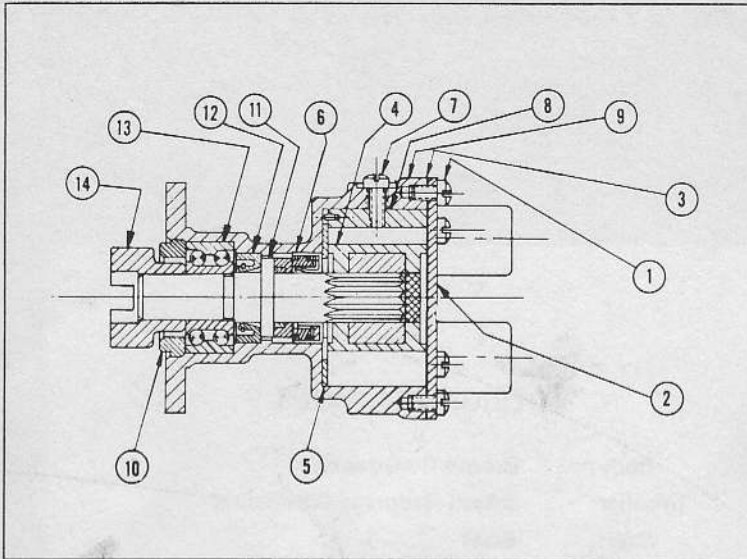

PARTS LIST

KEY	DESCRIPTION	PART NO.	QTY. REQ.
1	Screw—Fil-Hd	91003-0090	6
2	Cover—End	12055-0000	1
3	Gasket	8641-0000	1
4	Assy—Impeller	3085-0001	1
5	Wearplate	8493-0000	1
6	Seal—Rotary	96080-0080	1
7	Screw—Fil-Hd	91003-0110	1
8	Assy—Sub-Cam	8528-0000	1
9	Body	12054-0000	1
10	Ring—Adaptor	3376-0000	1
11	Shaft	12057-0000	1
12	Seal	92700-0180	1
13	Bearing—Ball	92600-0070	1
14	Coupling	8483-0000	1

For Model 12050-001 use Service Kit No. 90117-0121.
Minor Service Kit contains: Impeller, seal, and gasket.

Insist on Genuine Jabsco parts—made only by the Jabsco Products ITT — the original and world's leading manufacturer of self-priming flexible neoprene impeller pumps.

SERVICE INSTRUCTIONS

DISASSEMBLY

1. Remove end cover screws, end cover and gasket.
2. Remove impeller by grasping hub with water pump pliers.
3. Remove cam screw and cam. Clean off Permatex.
4. Remove wearplate.
5. Pressing on impeller end of shaft, press out bearing, shaft, bearing seal, shaft seal seat and coupling assembly.
6. Disassemble shaft assembly. Support bearing on inner race and press on drive end of shaft to remove coupling, bearing and bearing seal.
7. Remove shaft seal from body, pressing from bearing bore end of body.

NOTE: Inspect all parts for wear or damage and replace if necessary.

ASSEMBLY

1. Install bearing seal on oiled shaft with lip facing away from shaft shoulder.
2. Press bearing on the shaft, support inner race.
3. Install shaft assembly into body by pressing on outer race of bearing.
4. Install adaptor ring into body.
5. Press coupling on shaft. Support spline end of shaft.
6. Install seal assembly into body seal bore with carbon face against the ceramic seal seat. Press on outermost edge of seal case to prevent damage to seal.
7. Install wearplate in body bore, aligning slot in wearplate with dowel pin in cam.
8. Permatex cam screw threads and top surface of cam and install into body with cam screw.
9. Lubricate impeller bore with a light coat of Marfax 2HD grease and install impeller into body bore. Start impeller with a rotary motion, until splines engage, then push into bore.
10. Install gasket and end cover and secure with end cover screws.

JABSCO PRODUCTS ITT

Marine and Recreation Components Division
International Telephone and Telegraph Corporation
1485 Dale Way, Costa Mesa, California 92626
Telephone: (714) 545-8251