

**JABSCO**<sup>®</sup>

# Model 12280-0001

## SELF-PRIMING PUMPS FEATURES

Body:	Bronze
Impeller:	Jabsco Neoprene Compound
Shaft:	Stainless Steel
Shaft Seal:	Carbon-Ceramic Face Type
Ports:	1 1/4" (32mm) Slip-On Hose
Weight:	5 1/4 lbs. (2,6 kg) Approximate

Model 12280-0001

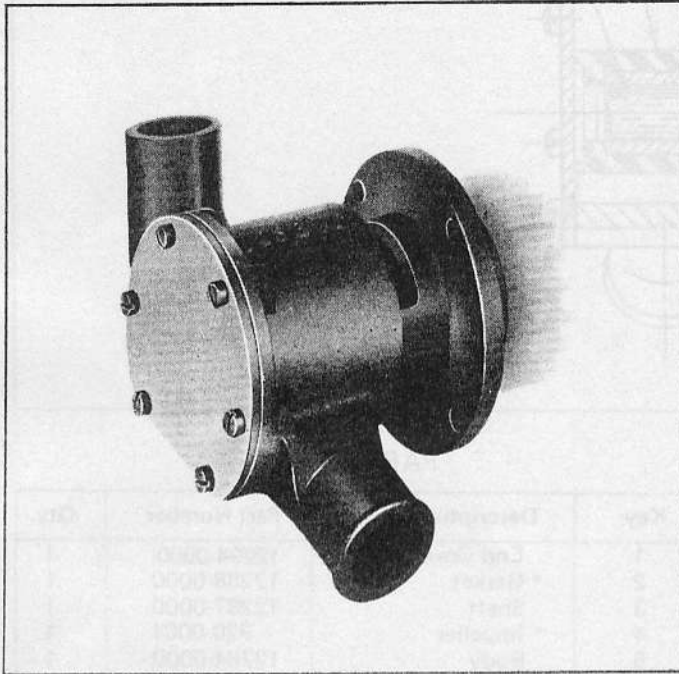

## APPLICATION Marine Engine Cooling

For Owens Flagship V-8 Engines from 1959 to 1970 (center-mounted pumps only).  
For Flagship Marine Engines - 283 cu. in., 327 cu. in. and 350 cu. in.

## DIMENSIONAL DRAWING

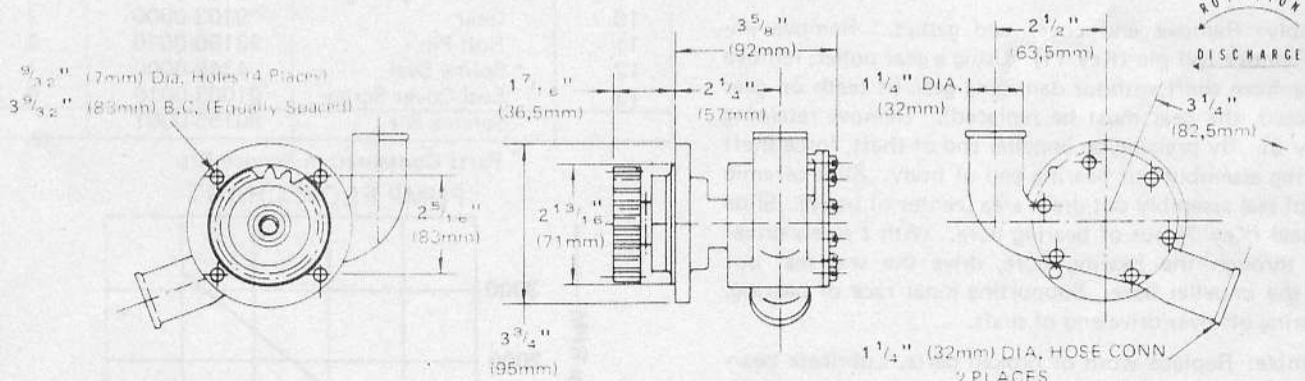

## INSTALLATION

Make sure flange seats squarely on mounting surface and bolt to engine. Connect inlet and outlet fittings. Intake and discharge piping of the engine must correspond with the proper port markings on the pump. NOTE: The 12280-0001 pump may also be used to replace the gear pump on earlier Flagship V-8's. The inlet port is tapped for 1/4" I.P.T. Use pipe compound or teflon tape on threads and install a 1/4" nipple for 1" I.D. hose connection from oil cooler to pump inlet. Connect discharge port with 1 1/4" I.D. hose to a tee (1 1/4" x 3/4" x 3/4" I.D. hose) in order to split water flow to each engine bank.

## OPERATION

Pump will self prime at low or high speeds. Make sure scoop and inlet line are clear and all connections airtight. Do not run pump dry for more than 30 seconds. Lack of water flow may damage impeller. To drain pump, loosen end cover screws.

## CROSS-SECTION VIEW

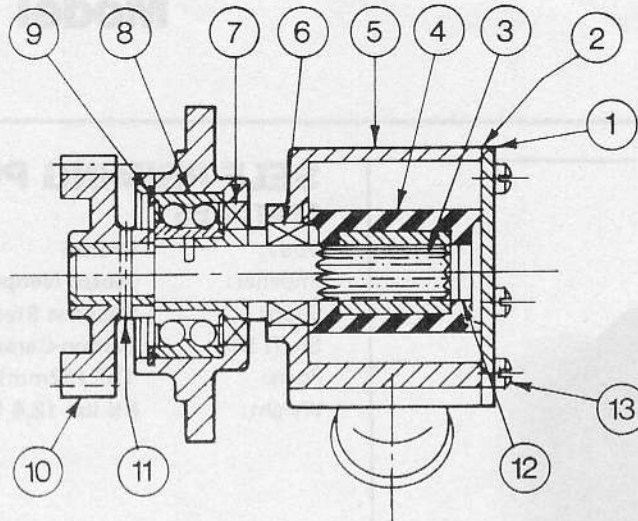

### SERVICE INSTRUCTIONS

**Impeller Replacement:** Remove end cover and gasket. Pull impeller out by grasping hub or blades with pliers. Replace impeller, gasket and end cover. A light coating of grease in impeller bore will aid priming on dry start up. Use correct Jabsco gasket; a thicker or thinner gasket may cause impeller damage. Standard gasket is 0.010" thick.

**Major Repair:** Remove pump from engine to replace seal assembly, bearings, or shaft.

**Disassembly:** Remove end cover and gasket. Remove impeller. Remove roll pin (Key 11). Using a gear puller, remove drive gear from shaft without damaging gear (if teeth on gear are damaged, the gear must be replaced). Remove retaining ring (Key 9). By pressing on impeller end of shaft, force shaft and bearing assembly out bearing end of body. Slide ceramic portion of seal assembly out drain area (center of body). Slide bearing seal (Key 7) out of bearing bore. With a screw driver inserted through the bearing bore, drive the seal seat out through the impeller bore. Supporting inner race of bearing, press bearing off over drive end of shaft.

**To Assemble:** Replace worn or broken parts. Lubricate bearing seal with water pump grease, or equivalent, and press into body bearing seal bore with lip facing drive end of pump. Press bearing on to well-oiled shaft. Place shaft and bearing assembly (splined end first) into body bearing bore and press on bearing outer race until in place. Install retaining ring. Supporting splined end of shaft, press drive gear onto drive end of shaft and replace roll pin. Place ceramic portion of seal assembly over splined end of shaft and up against washer (flat side of ceramic seat must face impeller bore). Lubricate with water (do not use oil) to ease assembly. Lightly Permatex\* O D surface of seal case and with carbon facing ceramic, press on outer edge of seal seat until flush with rear of impeller bore. Lubricate impeller bore with a light coat of water pump grease and install impeller. Install gasket and end cover.

**THE PRODUCT DESCRIBED HEREIN IS SUBJECT TO THE JABSCO ONE YEAR LIMITED WARRANTY, WHICH IS AVAILABLE FOR YOUR INSPECTION UPON REQUEST.**

Permatex\* is a trademark of Permatex Company.

### PARTS LIST

Key	Description	Part Number	Qty.
1	End Cover	12294-0000	1
2	* Gasket	12288-0000	1
3	Shaft	12287-0000	1
4	* Impeller	920-0001	1
5	Body	12284-0000	1
6	* Seal	96080-0080	1
7	Bearing Seal	913-0000	1
8	Ball Bearing	92600-0060	1
9	Retaining Ring	18724-0000	1
10	Gear	9103-0000	1
11	Roll Pin	93100-0040	1
12	* Spline Seal	4345-0000	1
13	End Cover Screw	91003-0010	6
	Service Kit	90155-0001	

\* Parts Contained in Service Kit.

### PUMP FLOW CHART

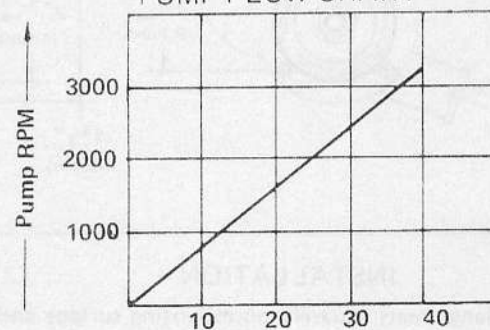

Flow in U.S. GPM  
Typical Flow in Average Engine  
Cooling Application\*

\*Average engine cooling applications have discharge pressures of 10-15 p.s.i. and intake vacuums of 3-5 inches of mercury.

**Jabsco**  
1485 Dale Way P.O. Box 2158  
Costa Mesa, CA 92628-2158  
Telephone: (714) 545-8251