

**JABSCO**<sup>®</sup>

**Model 14210-0001**

**SELF-PRIMING PUMPS  
FEATURES**

- Body: **Bronze**
- Impeller: **Jabscos Neoprene Compound**
- Shaft: **316 Stainless Steel**
- Shaft Seal: **Carbon-Ceramic Face-Type**
- Ports: **3/4" Dual Discharge  
(Hose Connections)**  
**1 1/4" Single Inlet  
(Hose Connections)**
- Weight: **Approx. Shipping Weight 5 1/2 lb**

**APPLICATION:**  
MARINE ENGINE COOLING

**FOR ENGINE MODELS:**  
Flange-Mounted Model for  
Owens Flagship V-8 Marine  
Engine—1960 and Subsequent

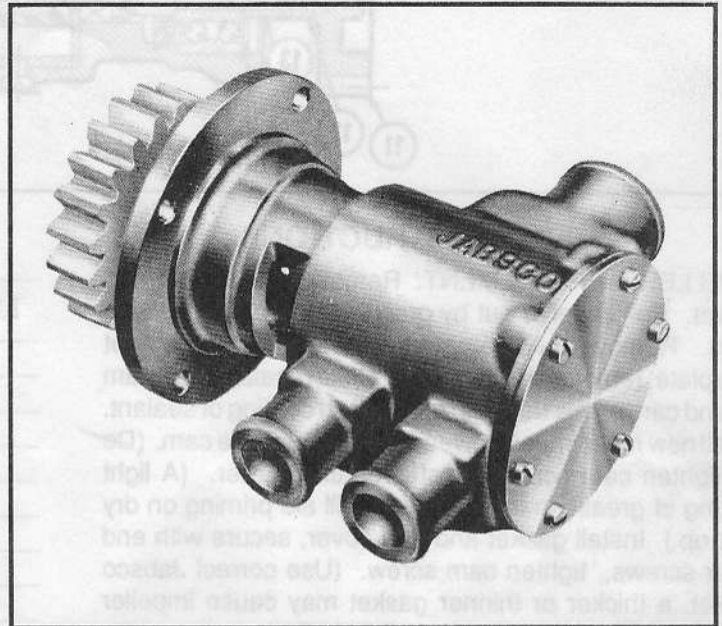

Model 14210-0001

MODEL: 14210-0001

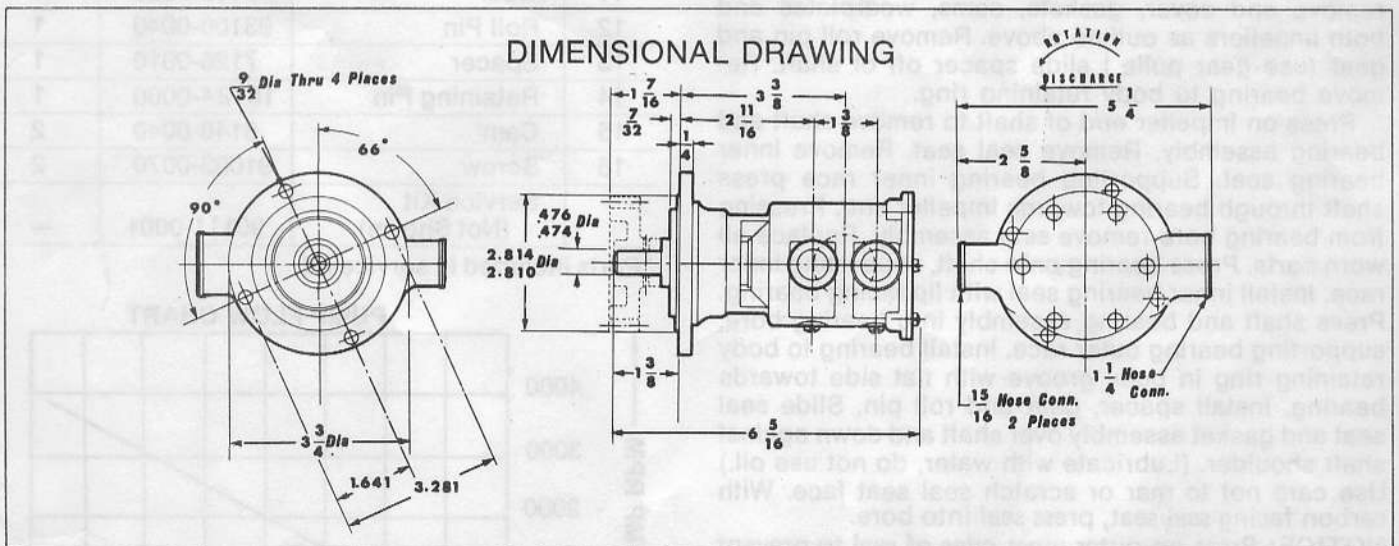

**INSTALLATION INSTRUCTIONS**

Pump should be mounted with the inlet port slanted toward the oil cooler. As the various engine models may be equipped with different transmissions, the pump mounting holes have been located for maximum clearance; however, filing of the pump body may be desirable in some instances to obtain sufficient clearance.

**OPERATING INSTRUCTIONS**

Pump will self prime at low or high speeds. Make sure scoop and inlet line are clear and all connections air tight. Do not run pump dry for more than 30 seconds. Lack of water flow may damage impeller.

## CROSS SECTION DRAWING

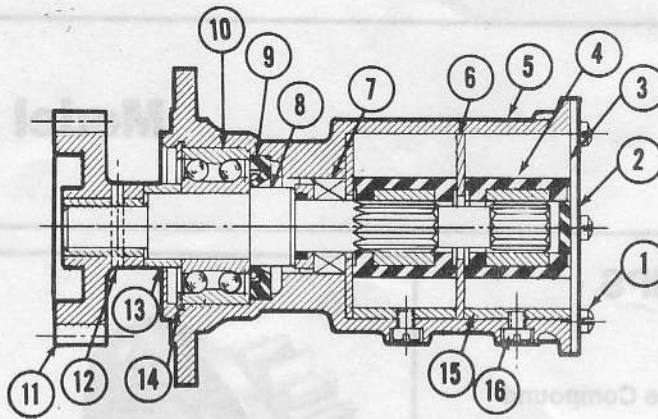

### SERVICE INSTRUCTIONS

**IMPELLER REPLACEMENT:** Remove end cover and gasket. Pull impeller out by grasping hub or blades with pliers. Remove outside cam screw and cam. Pull out wearplate, remove inner impeller. Clean sealant off of cam top and cam screw threads, apply fresh coating of sealant. Install new inner impeller, wearplate and outside cam. (Do not tighten cam screw.) Install outer impeller. (A light coating of grease in impeller bore will aid priming on dry start up.) Install gasket and end cover, secure with end cover screws, tighten cam screw. (Use correct Jabsco gasket, a thicker or thinner gasket may cause impeller damages.) Standard gasket is 0.010" thick.

**MAJOR REPAIR:** Remove pump from engine to replace seal, bearings or shaft. To disassemble pump, remove end cover, gaskets, cams, wearplates and both impellers as outl ne above. Remove roll pin and gear (use gear pulle ) slide spacer off of shaft. Remove bearing to body retaining ring.

Press on impeller end of shaft to remove shaft and bearing assembly. Remove seal seat. Remove inner bearing seal. Supporting bearing inner race press shaft through bearing towards impeller end. Pressing from bearing bore remove seal assembly. Replace all worn parts. Press bearing onto shaft, supporting inner race. Install inner bearing seal with lip facing bearing. Press shaft and bearing assembly into bearing bore, supporting bearing outer race. Install bearing to body retaining ring in body groove with flat side towards bearing. Install spacer, gear and roll pin. Slide seal seat and gasket assembly over shaft and down against shaft shoulder. (Lubricate with water, do not use oil.) Use care not to mar or scratch seal seat face. With carbon facing seal seat, press seal into bore.

**NOTICE:** Press on outer-most edge of seal to prevent damage, and press flush with bottom of body impeller bore. Install wearplate in body, inner cam (do not tighten cam screw), inner impeller, next wearplate, outer cam (do not tighten cam screw), and impeller, gasket, end cover and secure with end cover screws. Tighten both cam screws.

### PARTS LIST

KEY	DESCRIPTION	PART NUMBER	QTY. REQ.
1	Screw (End Cover)	91002-0020	6
2	End Cover	11830-0000	1
3	*Gasket	3298-0000	1
4	*Impeller	1210-0001	2
5	Body	14214-0000	1
6	Wearplate	7038-0000	2
7	*Seal	96080-0080	1
8	Shaft	14217-0000	1
9	Bearing Seal	913-0000	1
10	Ball Bearing	92600-0060	1
11	Gear	9103-0000	1
12	Roll Pin	93100-0040	1
13	Spacer	7126-0010	1
14	Retaining Pin	18724-0000	1
15	Cam	6148-0040	2
16	Screw	91003-0070	2
	Service Kit (Not Shown)	90111-0001	—

\*Parts included in service kit.

### PUMP FLOW CHART

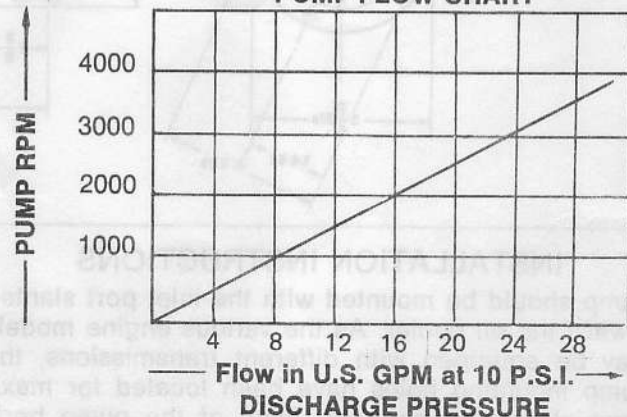

**ITT Jabsco**

ITT Fluid Technology Corporation  
1485 Dale Way, P.O. Box 2158, Costa Mesa, CA 92628-2158  
Tel: (714) 545-8251; Fax: (714) 957-0609  
Bingley Road, Hoddesdon, Hertfordshire EN11 0BU England  
Tel: 0992-467191; Tlx: 263251 G; Fax: 0992-467132

THE PRODUCTS DESCRIBED HEREIN ARE SUBJECT TO THE JABSCO® ONE YEAR LIMITED WARRANTY, WHICH IS AVAILABLE FOR YOUR INSPECTION UPON REQUEST.