

JABSCO

Models: 17590-SERIES 17430-SERIES

Models: 17590-SERIES, 17430-SERIES

SELF-PRIMING PUMPS

FEATURES

Pump Series No.: **17590-Series Pedestal Mounted
17430-Series Motor Pump Unit**

Body: **Glass-filled Epoxy**

Impeller: **Neoprene, Nitrile or Viton***

Shaft Seal: **Mechanical, Carbon-on-Ceramic, Nitrile**

Ports: **1/2" NPT Internal**

Shaft: **Corrosion Resistant Steel with Epoxy
Drive Sleeve in Contact with Fluid**

Motor: **115 Vac, Single Phase, 60Hz, 1/2 HP,
1725 RPM, TEFC, overload protected,
capacitor start. Three-pronged
grounded plug.**

Weight: **17590-Series 7-1/2 lb (3,4 kg)
17430-Series 33-1/2 lb (15,2 kg)**

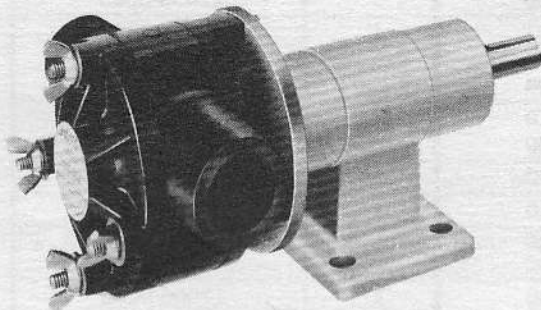

17590-Series

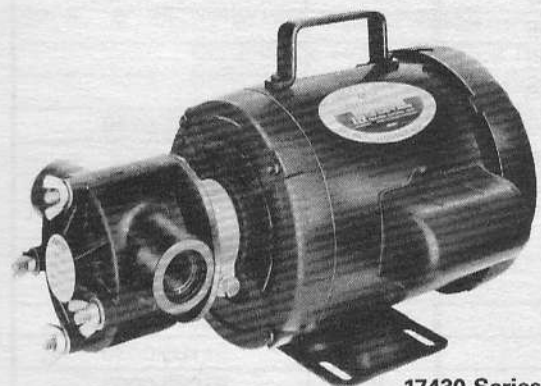

17430-Series

⚠ MOTOR WARNING

MOTOR CAN SPARK.
EXPLOSION & DEATH
CAN OCCUR.
DO NOT USE WHERE
FLAMMABLE VAPORS
ARE PRESENT.

Designed for transfers, circulation, spill returns, filtration and filling line use. Easily handles pure solutions, foaming liquids, emulsions, suspended solids, gels and ferments. Because the plastic pump is resistant to corrosion and metallic contamination, it is widely used for pumping photo chemicals, plating compounds, lab solutions, pharmaceuticals, cosmetics, weak acids, alkalies, liquid fertilizers, insecticides, dyes, detergents, waxes and many more. There is no pump metal part in contact with the fluid. See the JABSCO Pump Chemical Resistance Table which has been prepared to help you select the most suitable impeller and pump material.

- 1. INSTALLATION** – Pedestal Mounted Pump may be mounted in any position. The rotation of the pump shaft determines the location of the pump's intake and discharge ports. Refer to end cover. Before starting, rotate the pump shaft in the direction of the operating rotation.
- 2. DRIVE** – Belt or direct with flexible coupling for pedestal mounted unit. Clearance should be left between drive shaft and pump shaft when installing coupling. Always mount pump and align drive shaft before tightening the coupling set screw.
- 3. SPEEDS** – Pedestal Mounted Pump - 100 RPM to the maximum shown in the performance table. For longer pump life, operate at lowest possible speeds.

Viton* is a trademark of E. I. Du Pont de Nemours and Company.

MODEL	DESCRIPTION
17590-0001	Neoprene Impeller
17590-0003	Nitrile Impeller
17590-0004	Viton Impeller, Seal and O-Ring
17430-0001	Neoprene Impeller
17430-0003	Nitrile Impeller
17430-0004	Viton Impeller, Seal and O-Ring

- 4. SELF-PRIMING** – Primes at low or high speeds. For vertical dry suction lift of 15 feet, a minimum of 1750 RPM is required. Pump will produce suction lifts up to 22 feet when wetted. **BE SURE SUCTION LINES ARE AIRTIGHT OR PUMP WILL NOT SELF PRIME.**
- 5. RUNNING DRY** – Unit depends on liquid pumped for lubrication. **DO NOT RUN DRY FOR MORE THAN 30 SECONDS.** Lack of liquid will damage the impeller and plastic components.
- 6. DISCHARGE LINE** – When transferring liquids further than 25 feet, use one size larger discharge line than discharge opening.
- 7. NOTICE** – If corrosive fluids are handled, pump life will be prolonged if flushed with water after each use or after each work day. Consult ITT Jabsco Chemical Resistance Table (available from the factory) or the factory for further information.
- 8. PRESSURES** – For continuous operation, pressure should not exceed 20 psi.
- 9. TEMPERATURES** – Neoprene-45° to 180°F (7° to 81°C),
Nitrile -50° to 180°F (10° to 81°C),
Viton-60° to 180°F (15° to 82°).
- 10. SPARE PARTS** – A spare impeller and seal should be kept on hand to eliminate downtime.

PARTS LIST

KEY	DESCRIPTION	PEDESTAL VERSION MODEL 17590		MOTOR PUMP UNITS MODEL 17430	
		QTY. REQ.	PART NO.	QTY. REQ.	PART NO.
1	WING NUT	4	91107-0030	4	91107-0030
2	WASHER	12	91601-0040	4	91601-0040
3	STUD	2	91090-0110		
4	STUD	2	91090-0040	2	91090-0040
5	END COVER	1	17434-0000	1	17434-0000
6	IMPELLER	1	14281-0001 14281-0003 14806-0004	1	14281-0001 14281-0003 14806-0004
7	O-RING	2	92000-0310 92000-0880	2	92000-0310 92000-0880
8	BODY	1	14924-0000	1	14924-0000
9	SEAL HOUSING	1	14533-0010	1	14533-0010
*10	SEAL ASSEMBLY, STANDARD CARBON/CERAMIC, VITON	1	96080-0280 96080-0290	1	96080-0280 96080-0290
11	DRIVE SLEEVE	1	17006-0000	1	17006-0000
12	BEARING SEAL	2	496-0000		
13	RETAINING RING	2	18716-0000		
14	BALL BEARING	2	92600-0120		
15	BEARING HOUSING	1	1269-0000		
16	HEX NUT	2	91085-0050		
17	BOLT	2	91095-0240	2	91095-0240
18	SHAFT	1	17597-0000		
19	KEY	1	91402-0110		
20	ADAPTOR			1	17433-0000
21	BOLT			2	91094-0120
22	COLLAR			1	98022-0700
23	MOTOR			1	93004-1850
24	NUT - ADAPTOR			1	91105-0030
25	BOLT - ADAPTOR			1	91095-0090

*Available as optional part: Seal Assembly
 Carbon/Carpenter 20 with Neoprene 17221-0050
 Carbon/Carpenter 20 with Viton 17221-0040

PUMP HEAD ONLY FOR MOTOR PUMP UNIT:
 w/NEOPRENE IMPELLER 17438-0001
 w/NITRILE IMPELLER 17438-0003
 w/VITON IMPELLER 17438-0004

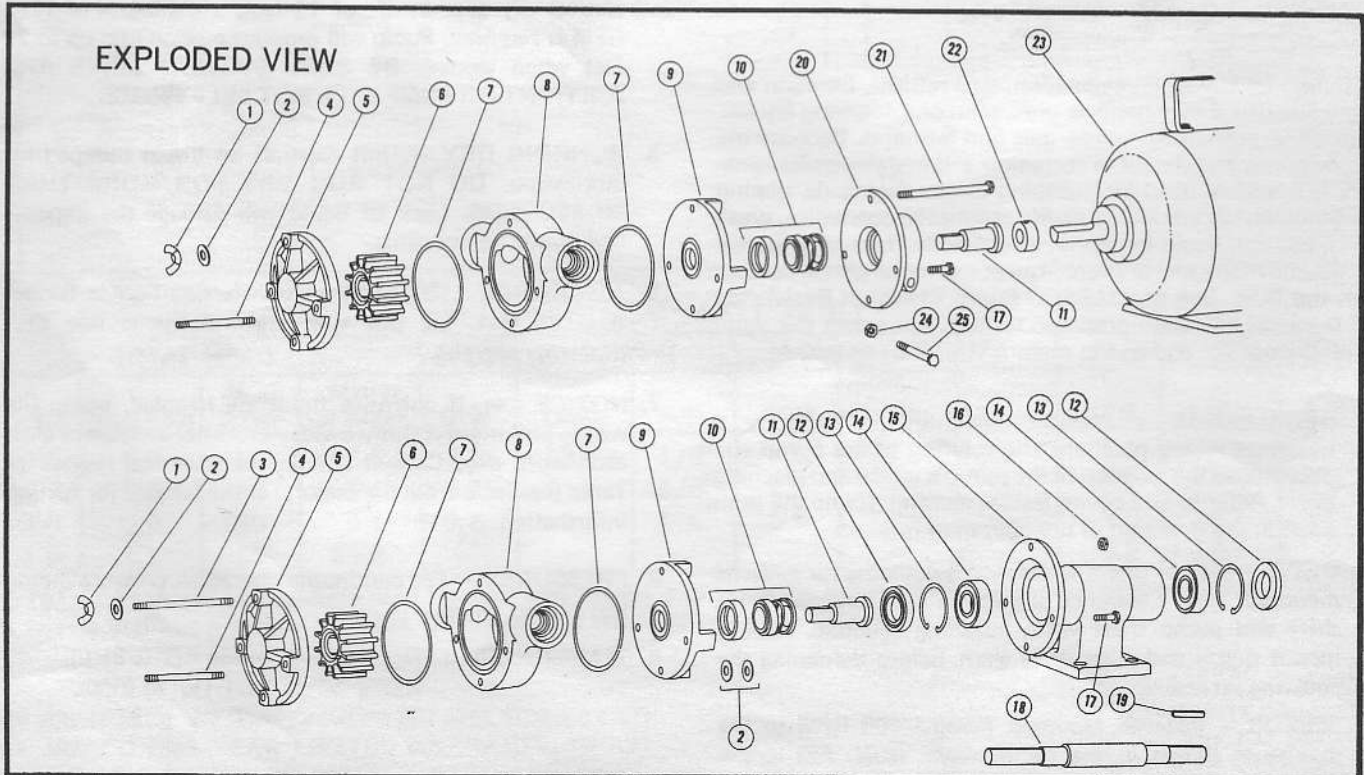

DISASSEMBLY AND ASSEMBLY INSTRUCTIONS

- Disassembly Steps
- Assembly Steps

TO REPLACE IMPELLER

- Step # 1. • Remove wing nuts, washers and end cover.
- Step # 2. • Remove pump head from seal housing. Remove O-rings from body grooves.
- Step # 3. • Push impeller from body bore.
- Step # 4. Install new impeller in lubricated body bore by grasping hub and with a rotary motion push it into the body bore. Replace O-rings in body grooves.
- Step # 5. Position the body over the through bolts against the seal housing.
- Step # 6. Install end cover and secure with washers and wing nuts.

TO REPLACE SEAL ASSEMBLY

- Step # 7. • Follow steps 1 •, 2 •, and 3 •.
- Step # 8. • Remove seal housing. Insert screw driver through seal seat bore and pry seat and grommet from seal housing.
- Step # 9. • Remove drive sleeve from shaft. Remove seal and seal spring from drive sleeve.
- Step #10. Install seal spring on drive sleeve. Lubricate seal with water and slide on drive sleeve with carbon facing away from spring. Install drive sleeve on shaft.
- Step #11. Install ceramic seal seat in grommet with grooved face towards grommet. Lubricate outer grommet surface with water and push seal seat assembly into seal housing with ceramic seal facing out of seal seat bore. Pedestal units only (17590-series) check to make sure there are two washers on each through bolt next to pedestal. Assemble seal housing over through bolts so seal and seat faces contact.
- step #12. Assemble impeller, body, and end cover as in steps 4 , 5 , and 6 .

TO SERVICE BEARING HOUSING (17590-Series)

- Step #13. • Follow steps 1 •, 2 •, 3 •, 8 •, and 9 •.
- Step #14. • Use a thin screw driver blade to pry inner bearing seal from pedestal. Use retaining ring pliers to remove retaining ring.
- Step #15. • Press on drive end of shaft to remove shaft and bearing assembly from pedestal.
- Step #16. • Use thin screw driver blade to pry outer bearing seal from pedestal.
- Step #17. • Support inner face of one bearing and press shaft through and out of bearing. Reverse shaft, support inner face of second bearing and press shaft through and out of bearing.
- Step #18. Support inner race of ball bearing, press shaft through bearing until shaft shoulder bottoms firmly against bearing inner race. Reverse shaft and repeat procedure to assemble second bearing on shaft.
- Step #19. Push shaft and bearing assembly into bearing housing from body end, secure with retaining ring in housing.
- Step #20. Press inboard bearing seal in bearing housing with lip facing impeller bore.
- Step #21. Press outboard bearing seal in bearing housing with lip facing outwards.
- Step #22. Assemble balance of pump parts following steps 10 , 11 , and 12 .

MODEL 17590-0001
17590-0003
17590-0004

DIMENSIONAL DRAWINGS
inches (millimeters)

ROTATION
DISCHARGE
DISCHARGE
ROTATION

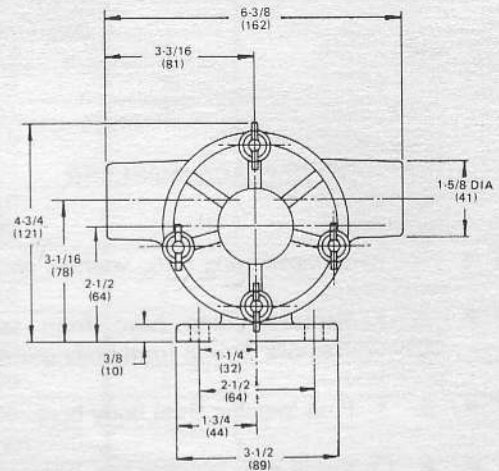
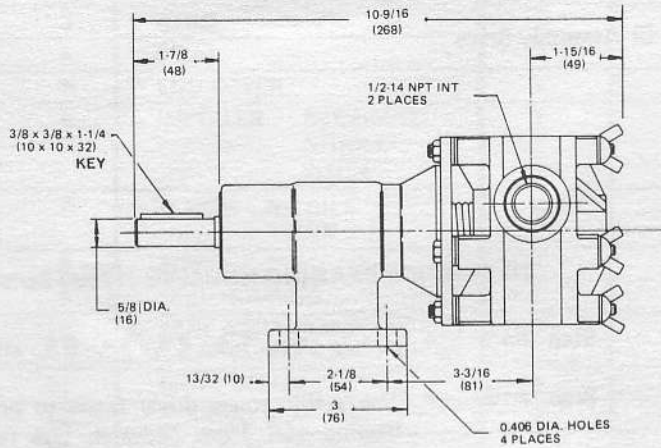

MODEL 17430-0001
17430-0003
17430-0004

ROTATION
DISCHARGE

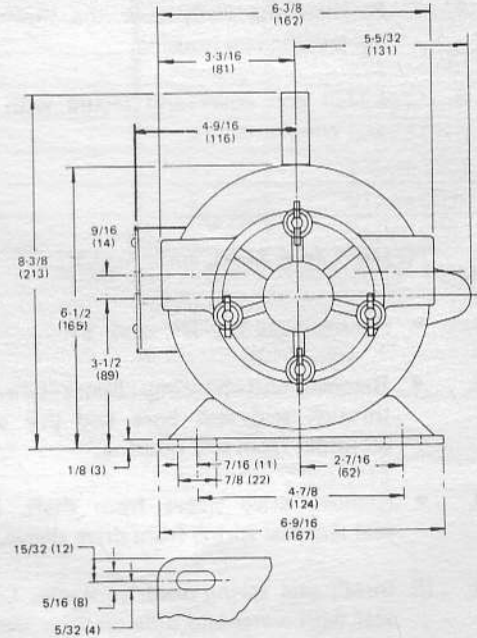
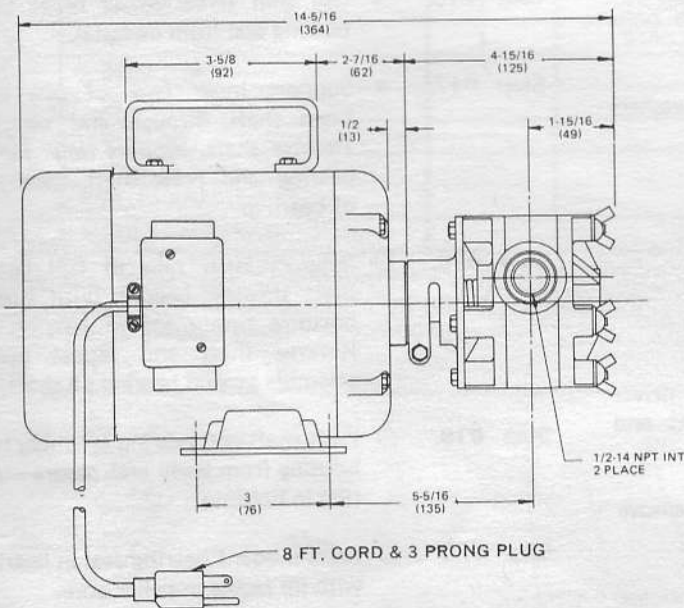

HEAD CAPACITY TABLE

TOTAL HEAD				FLOW @ 500 RPM			FLOW @ 1160 RPM			FLOW @ 1750 RPM		
PSI	Kg/Sq cm	Ft. of Water	Metres of Water	GPM	L/Min	H/P	GPM	L/Min	H/P	GPM	L/Min	H/P
4.3	0,3	10	3,0	3.5	13,2	1/6	7.5	28,4	1/4	11.3	42,8	1/2
8.7	0,6	20	6,1	3.1	11,7	1/6	6.7	25,4	1/4	10.2	38,6	1/2
13.0	0,9	30	9,1	2.6	9,8	1/6	5.5	20,8	1/3	9.0	34,1	1/2
21.6	1,5	50	15,2	—	—	—	—	—	—	5.2	19,7	1/2

NOTE: Table shows approximate head flow for new pumps with neoprene impeller. Capacities reduced approximately 10% with nitrile and viton impellers. Do not operate viton impeller above 15 psi.

THE PRODUCTS DESCRIBED HEREIN ARE SUBJECT TO THE JABSCO ONE YEAR LIMITED WARRANTY, WHICH IS AVAILABLE FOR YOUR INSPECTION UPON REQUEST.

ITT JABSCO
A Unit of ITT Corporation
1485 Dale Way, P.O. Box 2158
Costa Mesa, CA 92628-2158
Telephone: (714) 545-8251