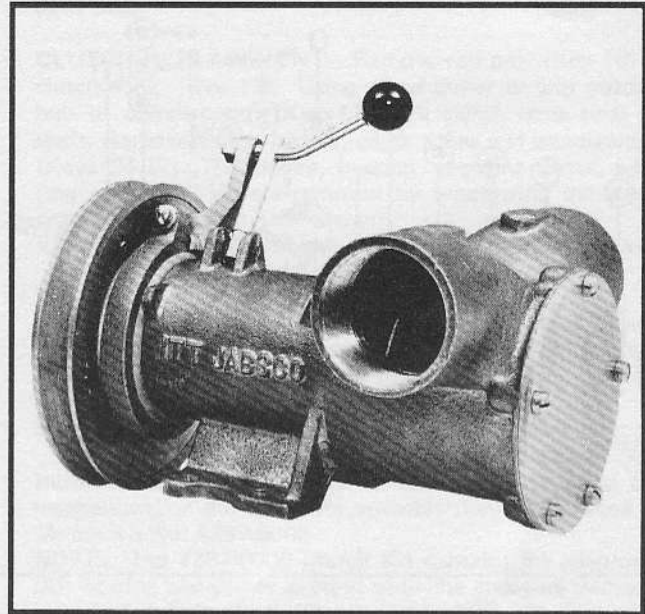

**JABSCO**[®]**Model 18310-0000**

SELF-PRIMING PUMPS MANUAL CLUTCH UNITS

FEATURES

Body:	Bronze
Impeller:	Nitrile 196
Shaft:	Brass
Ports:	2" NPT
Seal:	Carbon-Ceramic Face Type
Bearings:	Sealed Ball Bearings
Shipping Weight:	25 lb (11,3 kg)

**Model 18310-0000**

APPLICATIONS

MARINE: Engine cooling, Pumping bilges, Washdowns, Circulating water in bait tanks, Utility dock side pump.

INDUSTRIAL: Circulating and transferring, Velocity-mixing, Return spill, Sump drainage, Chemicals, Pharmaceuticals, Soap, Liquors, Ink, Dyes, Alcohol, Tanning Liquors, Glycerine, Brine, etc.

FARMING: Pumping water for stock, Pumping water from shallow wells and cisterns.

PUBLIC UTILITIES AND MUNICIPALITIES: Dewatering and draining meter boxes and excavations, Truck installation under hood for emergency pumping.

INSTALLATION

Pump may be mounted in any position which allows for clockwise rotation viewed from end cover. Counter clockwise rotation may cause premature clutch wear. Drive pump with an "A" or "B" size belt.

OPERATION

Pump will self-prime at low or high speeds. Make sure that all connections are airtight. Clutch will engage when clutch handle is moved to the left (as viewed from pulley end of unit). **DO NOT RUN PUMP DRY FOR MORE THAN 30 SECONDS. LACK OF WATER FLOW MAY DAMAGE IMPELLER.** To drain pump, loosen end cover screws. See Head Capacity Table for head pressures and flow. To avoid costly shutdowns, keep a Jabsco Service Kit on hand.



WARNING Exposed pulleys and belts can cause injury. Install shield around pulleys and belts.

EXPLODED VIEW

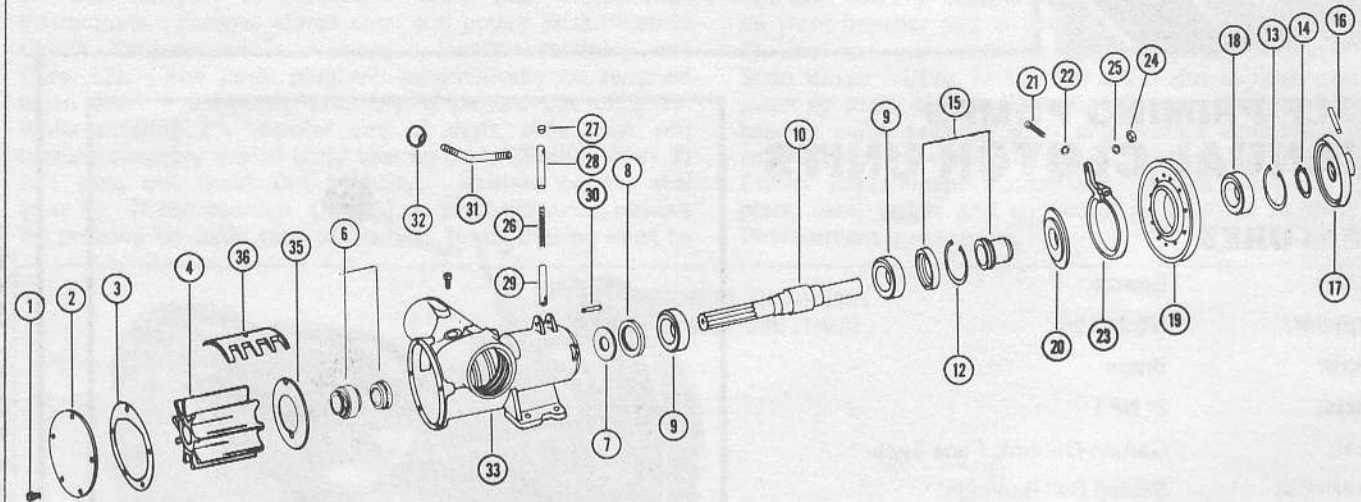

PARTS LIST

Key	Description	Part#	Qty.	Key	Description	Part#	Qty.
1	Screw, End Cover and Cam 1/4-20x1/2"	91005-0040	6	21	†Screw 1/4-20x1-1/4" Br. M.S.	91005-0060	1
2	End Cover	12062-0000	1	22	†Lock Washer 1/4"	91602-0060	1
3	* Gasket	816-0000	1	23	†Lever Ring	2470-0000	1
4	* Impeller	6760-0003	1	24	†Nut 5/16-24	91085-0090	1
6	* Seal Assembly (Shaft)	6408-0000	1	25	†Lock Washer 5/16"	91602-0080	1
7	Slinger	3181-0000	1	26	†Spring	3528-0000	1
8	Bearing Seal	92701-0180	1	27	†Rubber Plug	3530-0000	1
9	Ball Bearing	92600-0260	2	28	†Guide Tube	3525-0000	1
10	Shaft	10657-0010	1	29	†Guide Tube For Spring	3526-0000	1
12	†Retaining Ring (Body Plug to Body)	18725-0000	1	30	†Roll Pin	93100-0020	1
13	†Retaining Ring (Pulley to Bearing)	18726-0000	1	31	†Clutch Handle	2415-0000	1
14	†Retaining Ring (Engaging Sleeve to Bearing)	18723-0000	1	32	†Control Knob	92330-0010	1
15	†Body Plug and Engaging Sleeve	3856-0000	1	33	Body	18313-0002	1
16	†Roll Pin	93100-0010	1	35	Wearplate	2574-0000	1
17	†Clutch Cone	2473-0000	1	36	Cam	6988-0000	1
18	†Ball Bearing	92600-0330	1		Service Kit	90254-0001	
19	†Clutch Pulley	2472-0010	1		Clutch Kit	4387-0000	
20	†Adaptor Ring	2471-0000	1				

* Parts contained in Service Kit

† Parts contained in Clutch Kit

NOTE: All replacement parts shown (except Body/Bearing Housing Assembly) are interchangeable with earlier pump model 10660-0001.

SERVICE INSTRUCTIONS

IMPELLER REPLACEMENT: Remove end cover and gasket. Pull impeller out by grasping hub with pliers. Replace impeller, gasket and end cover. A light coating of grease on impeller bore will aid priming on dry startup. (Use correct Jabsco gasket; a thicker or thinner gasket may cause impeller damage). Standard gasket is 0.015" thick.

SHAFT SEAL REPLACEMENT: Remove end cover, gasket, and impeller as outlined above. Loosen cam screw and remove Cam (Key 36) (clean off sealant). Remove wearplate (Key 35) with screwdriver or hooked wire.

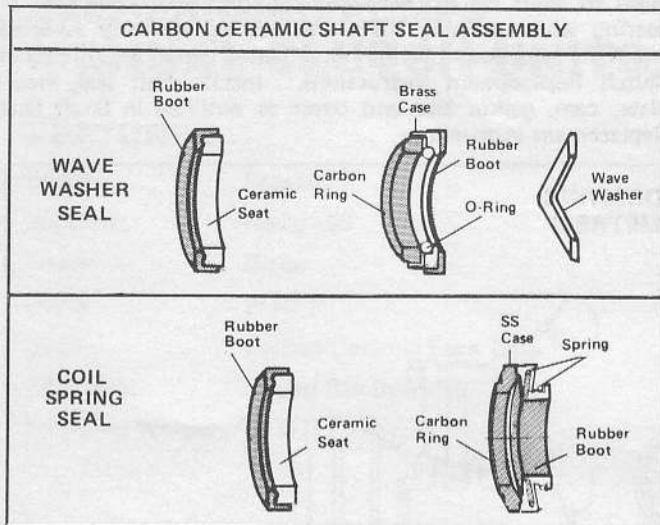

In this pump, either a wave washer seal or coil spring seal may be used. The wave washer is used only if the carbon portion of the seal does not have a coil spring attached.

Using a hooked wire, and taking care not to scratch shaft or seal seat bore, remove all components of seal assembly. Inspect shaft and seal seat bore to be sure sealing surfaces are free of nicks or scratches. Clean shaft surface behind splines to insure proper O-ring seal on shaft. Apply light film of grease on shaft surface behind spline area. Thoroughly clean seal faces (carbon and ceramic) of all grease, oil or particles — this will insure that seal faces will turn freely on startup. Place ceramic seat assembly in body with boot first. Use care not to damage ceramic surface. Be sure ceramic and boot are bottomed squarely in body bore. Slide carbon ring assembly, with carbon facing ceramic, over the shaft and firmly up against the ceramic seat. If carbon portion of seal does not have an integral coil type tensioning spring, slide wave washer over the shaft and against the rubber boot on metal case containing O-ring and carbon. Replace wearplate, aligning notch with dowel pin in body. Apply a thin coat of sealant to top of cam and threads on cam screw and install in impeller bore (leave cam screw loose). Replace impeller, gasket, and end cover. Tighten end cover screws. Tighten cam screw.

CLUTCH ADJUSTMENT: The Jabsco clutch engages and disengages by means of internal threads on the body plug and external threads on the engaging sleeve (Key 15). The lever ring (Key 23) is clamped to the adaptor ring (Key 20) which turns the engaging sleeve. When the lever ring (Key 23) is turned counterclockwise (facing pulley) the engaging sleeve, pulley bearing and pulley will move outward until the pulley engages with the clutch cone (Key 17). Adjustment is made by changing the location that the lever ring is clamped to the adaptor ring.

1. Move lever ring (Key 23) to the engage position (extreme left as viewed from pulley-end of the pump).
2. Loosen screw (Key 21) on lever ring.
3. Hold adaptor ring (Key 20) in place with a screwdriver to prevent it turning, and simultaneously rotate lever ring clockwise until pulley rotates freely (disengaged); approximately 1/4" (6-7 mm). The lever ring will slide on the adaptor ring more easily if a screwdriver is used to hold the split in the lever ring apart.

4. Tighten screw (Key 21) on lever ring. Check that lever ring permits clutch engagement. Repeat these clutch adjustment steps for more adjustment if needed.

Clutch adjustment is limited to the position beyond which the engaging sleeve threads do not provide a sturdy support for the belt load. Over-adjustment can cause pulley wobble with increased wear and slippage. If it becomes necessary to move the lever ring more than 1-1/2" (38 mm) or 45 degrees from its original position, the cone is badly worn and should be replaced to prevent undue strain on the engaging sleeve and body plug.

CLUTCH REPLACEMENT: Remove roll pin (Key 16) from clutch cone (Key 17). Using wheel puller to grip notches in hub of clutch cone (Key 17), pull clutch cone away from shaft. Remove clutch handle, guide tubes and associated parts (Keys 24-32). The pulley, bearing, engaging sleeve, adaptor ring and lever ring are removed by unscrewing the engaging sleeve from body plug as follows:

1. Facing pulley end of the pump, turn lever ring (Key 23) counterclockwise (left) to the stop on body.
2. Loosen screw (Key 21) on lever ring.
3. Hold engaging sleeve in place with a screwdriver placed between the shaft and the engaging sleeve, and simultaneously rotate lever ring clockwise to the stop on body.
4. Tighten screw (Key 21).
5. Repeat the above steps until engaging sleeve is unscrewed and pulley assembly comes loose from the pump.

Individual parts may be replaced in the pulley and clutch mechanism, or the complete assembly may be replaced using Clutch Kit No. 4387-0000.

NOTE: The 4387-0000 Clutch Kit contains the adaptor ring, ball bearing and pulley pressed onto the engaging sleeve, with retaining rings in place. Clutch pulley (Key 19), bearing (Key 18) and adaptor ring (Key 20) may be replaced individually by removing retaining rings (Keys 13, 14), pressing these components off the engaging sleeve, then squarely pressing new components onto the engaging sleeve. If body plug and engaging sleeve (Key 15) are to be replaced, remove retaining ring (Key 12), thread the old engaging sleeve into the body plug with a pipe wrench and force body plug away from bearing, then out of the body.

To reassemble clutch onto pump, press new body plug into place (if plug is being replaced) and install retaining ring (Key 12). Grease threads of body plug. Place assembled pulley, bearing, engaging sleeve and lever ring mechanism over shaft and against body plug. With lever ring in the "up" position, rotate lever ring clockwise to start threads of engaging sleeve onto the body plug. Thread engaging sleeve into the body plug as follows:

1. Facing pulley end of the pump, turn lever ring (Key 23) clockwise (right) to the stop on body.
2. Loosen screw (Key 21) on lever ring.
3. Hold engaging sleeve in place with a screwdriver placed between the shaft and the engaging sleeve, and simultaneously rotate lever ring counterclockwise (left) to the stop on body.
4. Tighten screw (Key 21).
5. Repeat the above steps until engaging sleeve is completely threaded into the body plug.

With engaging sleeve threaded all the way into body plug, and bottomed, loosen screw (Key 21) and rotate lever ring clockwise to the stop on body. Tighten screw (Key 21). Rotate lever ring to the left and hold in place at 15 degrees to the left of top center. Slide clutch cone (Key 17) onto shaft and push it tight against pulley. Using pilot hole on clutch cone hub as a guide, drill a 3/16" (4,76mm) diameter hole through the shaft and straight through the clutch cone hub. Insert roll pin (Key 16). With clutch fully engaged, lever ring should be approximately 30 degrees to the left of top center (facing pulley end of the pump). Check clutch engagement and perform any required adjustment using the "Clutch Adjustment" procedure. Install control handle hardware (Keys 24-32).

SERVICE INSTRUCTIONS (CONTINUED)

MAJOR REPAIR: Remove pump from installation for major repair.

Disassembly: Remove end cover, impeller, cam, wearplate and seal assembly as outlined in Shaft Seal Replacement instructions. Remove clutch cone and pulley as outlined in Clutch Replacement instructions. Remove retaining ring (Key 12). The body plug will automatically be removed when shaft and bearing assembly is pressed out of body. While pressing on impeller end of shaft, slide shaft and bearing assembly out of body bearing bore. Slinger (Key 7) will slide out drain slot in body. Remove bearing seal (Key 8). If ball bearings (Key 9) on shaft are worn, remove by pressing on inner race of bearing (inner bearing must be

pressed off over impeller end of shaft, and the outer bearing over drive end of shaft). Replace all worn or broken parts.

Assembly: While supporting inner race of bearings, press new ball bearings onto a clean well-oiled shaft. Wipe excess oil from impeller end of shaft. Press new bearing seal (Key 8) into seal bore with lip pointing toward impeller bore. Slide slinger (Key 7) through drain slot in body and into place so shaft can go through. Support the outer race of bearing while pressing shaft and bearing assembly (splined end first) into body bearing bore. Install clutch as outlined in Clutch Replacement instructions. Install shaft seal, wearplate, cam, gasket and end cover as outlined in Shaft Seal Replacement instructions.

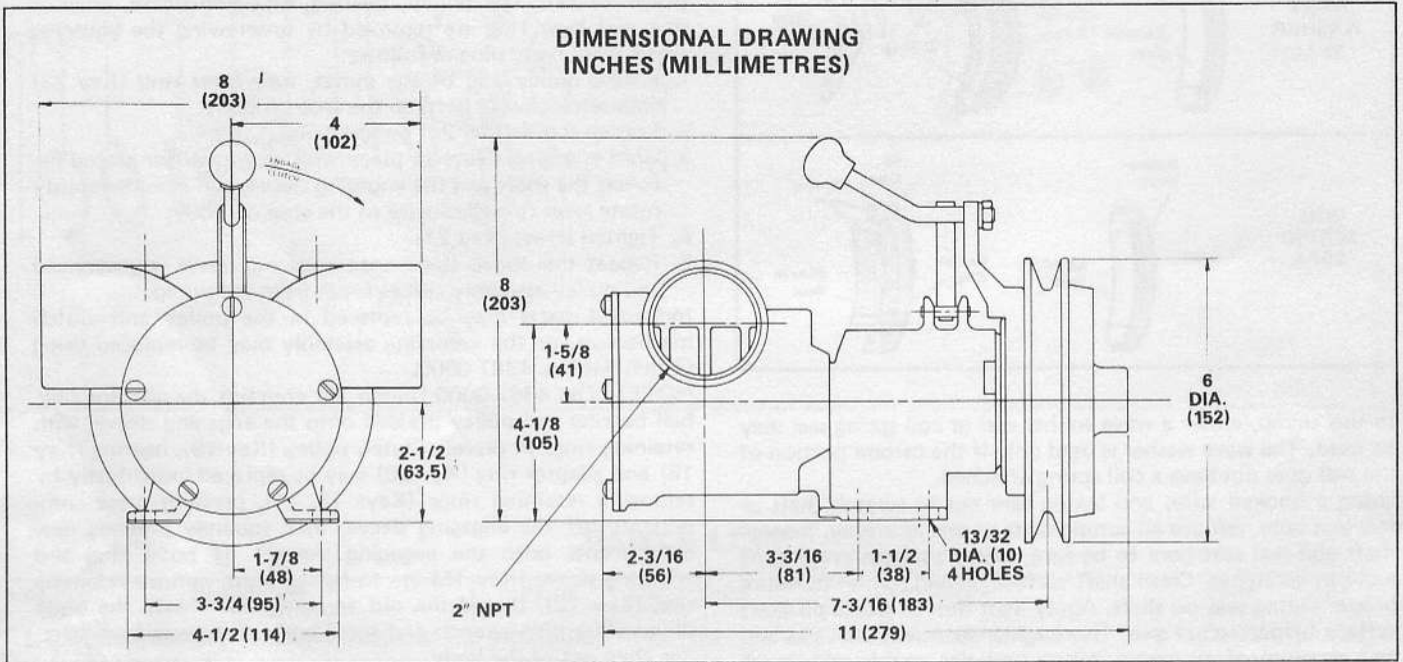

MODEL 18310-0000

HEAD CAPACITY TABLE

TOTAL HEAD				500 RPM			870 RPM			1160 RPM			1450 RPM			1750 RPM			2100 RPM			2450 RPM		
PSI	kg/cm ²	Feet of Water	Metres of Water	GPM	ℓ/min	HP	GPM	ℓ/min	HP	GPM	ℓ/min	HP	GPM	ℓ/min	HP	GPM	ℓ/min	HP	GPM	ℓ/min	HP	GPM	ℓ/min	HP
4.3	0,3	10	3,0	23	87	1/2	40	151	1	54	204	1	70	265	1-1/2	83	314	2	95	360	3	108	409	3
8.7	0,6	20	6,1	22	83	1/2	37	140	1	50	189	1	66	250	1-1/2	79	299	2	91	344	3	104	394	3
17.3	1,2	40	12,2	17	64	1/2	30	114	1	43	163	1-1/2	58	220	1-1/2	71	269	3	82	310	3	93	352	5
26.0	1,8	60	18,3	-	-	-	22	83	1-1/2	34	129	1-1/2	48	182	2	61	231	3	70	265	5	81	307	5
30.3	2,1	70	21,3	-	-	-	-	-	-	-	-	-	41	155	2	55	208	3	62	235	5	73	276	5

NOTE: Progressively longer life may be expected as operating pressures and speeds are reduced. Factory Application Engineering assistance suggested for operation in light shaded area and recommended for heavy shaded area. Table shows approximate Head-Flow for new pump in U.S. gallons per minute.

THE PRODUCT DESCRIBED HEREIN IS SUBJECT TO THE JABSCO® ONE YEAR LIMITED WARRANTY, WHICH IS AVAILABLE FOR YOUR INSPECTION UPON REQUEST.

ITT Jabsco

ITT Fluid Technology Corporation
 1485 Dale Way, P.O. Box 2158, Costa Mesa, CA 92628-2158
 Tel: (714) 545-8251; Fax: (714) 957-0609
 Bingley Road, Hoddesdon, Hertfordshire EN11 0BU England
 Tel: 0992-467191; Tlx: 263251 G; Fax: 0992-467132