



Model 18580-0000
115 Vac Centri-Puppy

BRONZE CENTRIFUGAL

FEATURES

Volute Body:	Bronze
Ports - Inlet:	3/4" NPT
Discharge:	3/4" NPT
Impeller	Bronze
Seal:	Lip Type, Viton* Compound
Motor:	1/8 HP 115/1/60, 3450 RPM, TENV, 6 Foot, 3 Prong Grounded Plug
Weight:	14-1/4 lb (31,5 kg)



**Explosion hazard. Motor can spark.
Explosion & death can occur. Do not use
where flammable vapors are present.**

DESCRIPTION

The ITT Jabsco bronze centrifugal pump is designed for continuous duty service. The close coupled, compact motor pump unit is equipped with a ball bearing motor and stainless steel shaft and has a service factor of 1.5 or greater. The Centri-Puppy is equipped with a Viton lip seal for application versatility. Unlike ITT Jabsco flexible impeller pumps, the centrifugal pump is not self-priming. Normal installation is flooded suction, that is, with the pump below the source liquid level so that liquid flows by gravity to the pump. The pump may be located above the liquid source, if a check valve or foot valve is installed at the beginning of the suction line; and, the pump and entire suction line is filled with liquid; and, all air is bled from the suction side when primed and will maintain its prime, as long as the foot or check valve functions as it should, without leaking. If the check valve leaks, the pump will not reprime, and must be manually primed in order to resume operation.

Published performance curves are based on pumping water at 68 degrees F. The motor horsepower is sufficient to provide full open discharge capacity at three (3) feet of head. As the head (pressure) against which the pump operates increases, the load on the motor decreases, thus the discharge may be throttled without danger of overloading the motor. Liquids of higher specific gravity (weight) than water require more power to generate the same performance available with water. The horsepower requirement increases directly as the increase in specific gravity.

It is not possible to increase the horsepower of a close coupled motor pump unit, therefore, to pump a liquid of higher specific gravity, with the centrifugal motor pumps, the capacity must be limited by restricting the discharge

* Viton is a trademark of Dupont Dow Elastomers



Model 18580-0000

to stay within the horsepower available. In other words, the discharge must be throttled to the extent that the motor full load amperage rating, found on the motor label, is not exceeded. Contact factory for application engineering assistance.

In all installations, make sure the suction is not restricted. Do not use an elbow fitting in the pump intake port. Starved suction can result in cavitation which will damage the pump and cause performance deterioration.

Viscous or thick liquids are difficult to pump with a small centrifugal pump. Do not attempt to pump liquids with a viscosity exceeding 1500 SSU (SAE 30 WT OIL at 75 degrees F) with a centrifugal pump. Consider, instead, the ITT Jabsco flexible impeller pump.

PERFORMANCE CHART

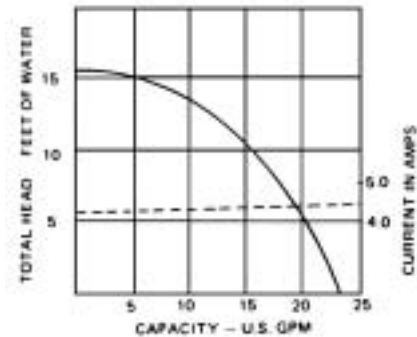

DIMENSIONAL DRAWING

Inches (Millimetres)

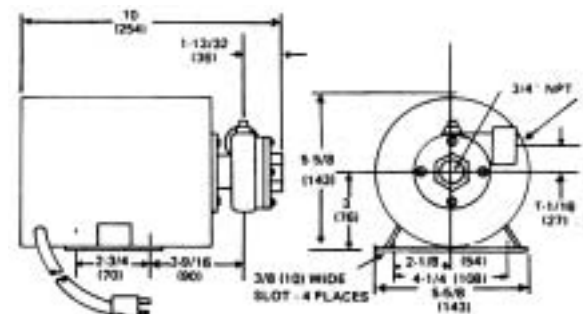

EXPLODED VIEW

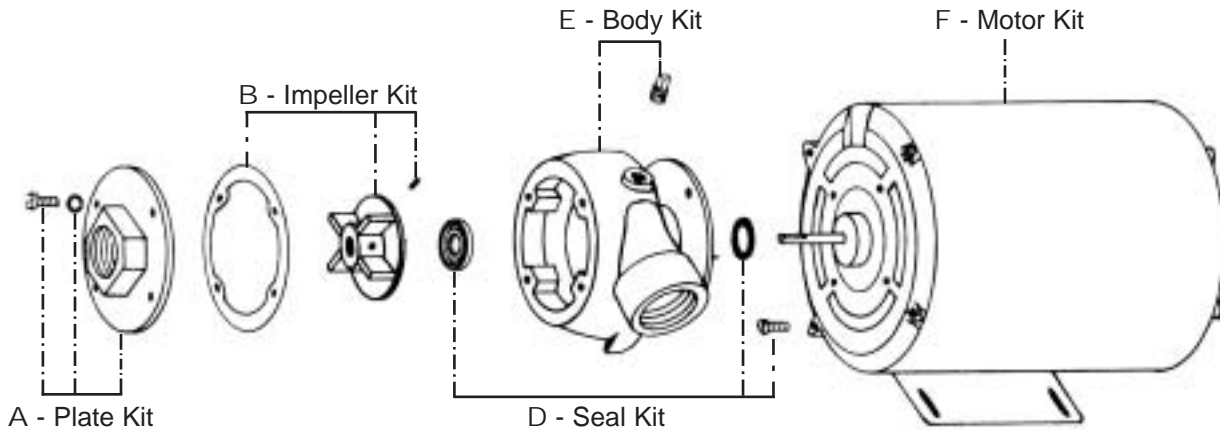

PARTS LIST

Kit	Description	Kit Number
A	Screw End Cover	18514-1000
	Lock Washer	
	End Cover	
B	Gasket	18515-2000
	Impeller	
	Set Screw - Impeller	

Kit	Description	Kit Number
D	Seal	1040-4101
	Screw - Motor Mtg. (3/kit)	
	Slinger	
E	Body - Volute Plug	18513-5000
F	Motor - ENV 115/1/60	18735-0082

DISASSEMBLY INSTRUCTIONS

1. Remove end cover screws, end cover and gasket.
2. Remove drain plug from body. Insert Allen wrench through priming hole to loosen impeller set screw. Withdraw impeller from shaft and body.
3. Remove two motor mounting screws. Remove body from motor.
4. Press seal out of body towards motor flange end. Check motor shaft for wear in seal lip area. Replace motor if shaft is deeply grooved. This will only happen, normally, if pump is run dry for extended periods.

ASSEMBLY INSTRUCTIONS

1. Support body on front face (impeller end). Lubricate OD of seal and press into seal bore with lip facing toward impeller until it bottoms firmly against shoulder. Center seal retainer (concave side up)

in seal cavity and press firmly against seal using 11/16" dia. dowel.

2. Position slinger on shaft 1/8" from motor face.
3. Lubricate inside diameter of seal and shaft with water pump grease. Install body to motor and secure with two screws.
4. Start set screw into impeller boss. Push impeller on shaft with set screw centered on shaft flat, until impeller contacts rear face of body. Pull impeller away from body 1/32" and tighten set screw by inserting Allen wrench through priming hole in body. Turn impeller to make sure there is no metal contact.
5. Install gasket, end cover and secure with four end cover screws and lock washers.
6. Install priming plug in body with a light coat of sealant.

REPLACEMENT PART KITS

JABSCO RECOMMENDS THAT ALL COMPONENTS IN EACH INDIVIDUAL KIT BE REPLACED AS A MATTER OF GENERAL MAINTENANCE.

THE PRODUCT DESCRIBED HEREIN IS SUBJECT TO THE JABSCO ONE YEAR LIMITED WARRANTY, WHICH IS AVAILABLE FOR YOUR INSPECTION UPON REQUEST.

Jabsco



ITT Industries

Engineered for life

U.S.A.
Jabsco
20 Icon,
Foothill Ranch, CA 92610-3000
Tel: (949) 609.5106
Fax: (949) 859.1254

UNITED KINGDOM
Jabsco
Bingley Road, Hoddesdon
Hertfordshire EN11 OBU
Tel: +44 (0) 1992 450145
Fax: +44 (0) 1992 467132

CANADA
Fluid Products Canada
55 Royal Road
Guelph, Ontario N1H 1T1
Tel: (519) 821.1900
Fax: (519) 821.2569

JAPAN
NHK Jabsco Company Ltd.
3-21-10, Shin-Yokohama
Kohoku-Ku, Yokohama, 222
Tel: 045.475.8906
Fax: 045.475.8908

GERMANY
Jabsco GmbH
Oststrasse 28
22840 Norderstedt
Tel: +49-40-53 43 73 -0
Fax: +49-40-53 53 73 -11