



Models 23180-9000 23180-9100



ROTARY VANE PUMP

FEATURES

- Body:** Cast Iron
- Ports:** 1" IPT
- Vanes:** Bronze
- Rotor:** Brass
- Shaft:** Stainless Steel
- Bearings:** Oilite
- Seal:** Lip
- Seal Housing:** Cast Iron
- Coupling:** Flexible Stainless Steel Spring
- Motor:** Permanent Magnet
Intermittent Duty (30 min.)
- Height:** 3-7/8" (98 mm)
- Length:** 10-1/16" (259 mm)
- Width:** 5-1/8" (130 mm)
- Weight:** 10 lbs (4,5 kg)

Models 23180-9000, 23180-9100

⚠ MOTOR WARNING

MOTOR CAN SPARK.
EXPLOSION & DEATH
CAN OCCUR.

DO NOT USE WHERE
FLAMMABLE VAPORS
ARE PRESENT.



WARNING: DO NOT USE TO PUMP GASOLINE OR FLAMMABLE LIQUIDS.

MODELS AVAILABLE

- 23180-9000 12 Vdc
- 23180-9100 24 Vdc

APPLICATION

The Jabsco Rotary Vane pump is ideal for transferring diesel fuel. The brass rotor and bronze vanes are not affected by petroleum products. It is self-priming with a suction lift of up to eight feet and can pump against a discharge head of up to ten feet.

NOTICE: Do not pump water or corrosive fluids. Do not pump oils with a viscosity greater than SAE 10W. Pump and/or motor damage may result.

INSTALLATION

The pump must be mounted in a dry location positioned horizontally – the motor is not waterproof and must not be submerged. SELECTION OF A COOL, VENTILATED location will generally extend pump motor life. The pump may be mounted at 90 degree increments on the bearing house to allow plumbing connections as needed.

PLUMBING CONNECTIONS

Pumps ports are tapped with 1" NPT threads. Use rigid plumbing or flexible hose that does not kink when bent and with sufficient wall thickness to prevent collapse when used on suction side of pump. Plumbing should be routed so that some fluid will be retained in pump body to wet the rotor and vanes. Wetting the rotor and vanes aids in priming. Use a strainer on the intake if debris or solids are present in the fluid being pumped. ALL plumbing connections must be airtight to enable fast priming.

PSI	TOTAL HEAD		CAPACITY	
	FEET	METRES	GPM	l/MIN
2.1	5	1,5	13	49
4.3	10	3,0	12	46

Table shows approximate Head-Flow for new pump.



ELECTRICAL CONNECTIONS

Connect black wire to negative (-) terminal of battery. The orange wire with the fuse holder should run to an overload protected switch or circuit breaker, with a wire from switch or breaker to positive (+) terminal of battery. Motor rotation is clockwise looking at shaft end of motor. Use proper wire size as determined by wire table elsewhere on this sheet. Should this fuse blow, replace with same size fuse after determining reason for blown fuse.

WIRING DIAGRAM

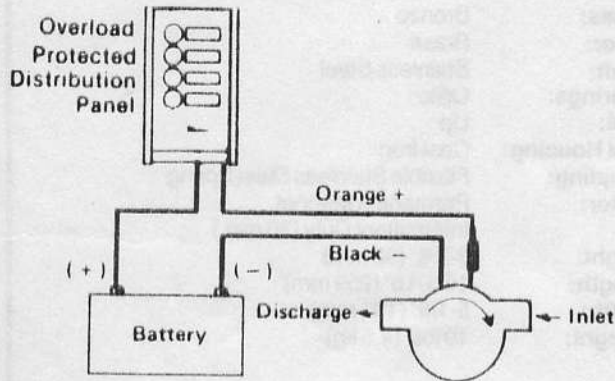

MODELS	VOLTAGE	AMP DRAW	FUSE SIZE
23180-9000	12 Vdc	15	20 Amp
23180-9100	24 Vdc	7.0	10 Amp

RECOMMENDED MINIMUM WIRE SIZES

CONNECTION LENGTH BETWEEN BATTERY AND MOTOR	12V	24V
1-10 ft. (3m)	#10	#16
11-20 ft. (6m)	#6	#12
21-30 ft. (9m)	#6	#10

Above recommendations are for a maximum 3% voltage drop.

NOTICE: To prevent motor damage, use only multi-strand copper wire in size recommended. DO NOT use ordinary lamp cord or other substitutes.

NOTICE: No warranty consideration will be given to pumps that are returned without the properly sized fuse and fuse holder supplied with the pump.

OPERATION

Rotary Vane pumps must NOT be run dry, as the pumped liquid is the lubricant for the rotor and vanes. Observe the outlet and shut off pump as soon as liquid stops flowing.

The pump cannot run against a closed outlet such as encountered when using a garden hose type shut-off nozzle. Pressure for normal operation should not exceed 10 feet of head (4.3 PSI). Excessive pressures will cause fuse to blow.

Temperature of pumped liquid may be in the range of 45°-165°F (10°-78°C).

DIMENSIONAL DRAWING INCHES (millimetres)

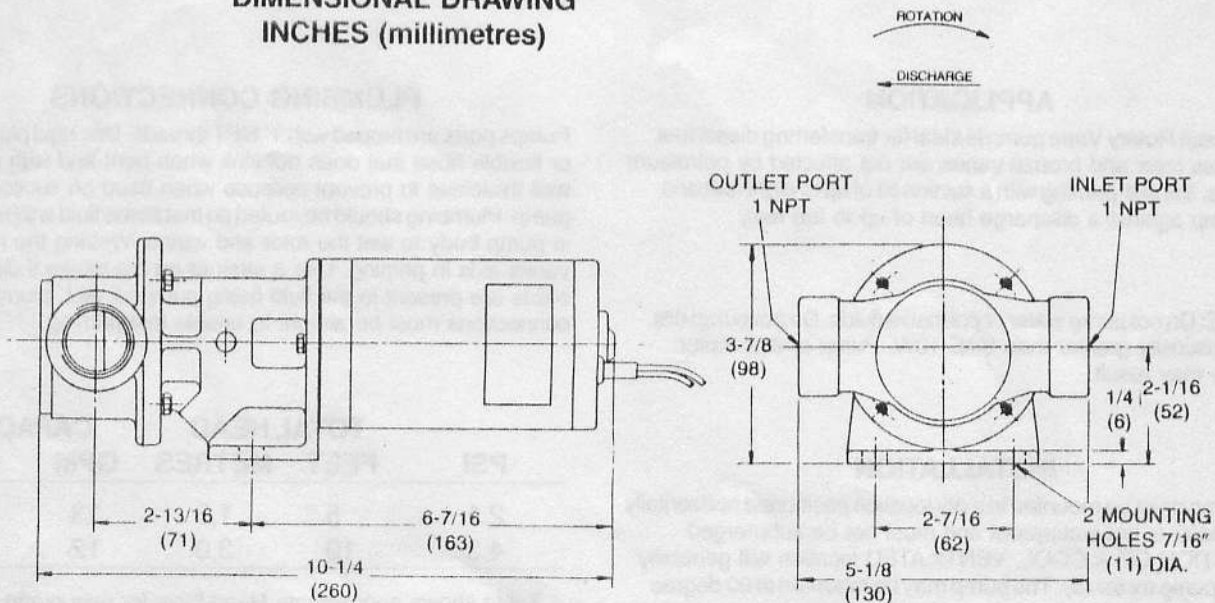

EXPLODED VIEW

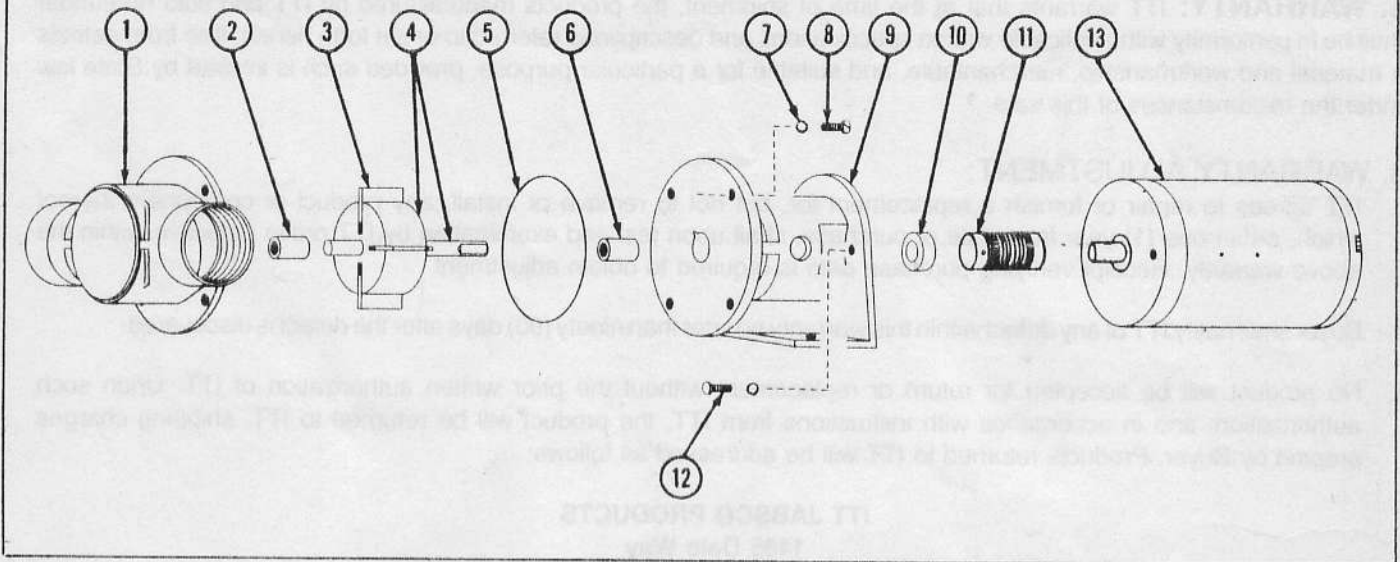

KEY	PART NUMBER	DESCRIPTION	QTY. REQ.
1	23184-0000	Body	1
2	23188-0000	Bushing (grooved)	1
3	23183-0000	Vanes	4
4	23186-0000	Rotor/Shaft Assy.	1
5	18753-0086	O-Ring	1
6	92590-0035	Bushing	1
7	18753-0087	Lock Washer	4
8	18753-0088	Hex Bolt	4
9	23181-0000	Seal Housing	1
10	92701-0504	Seal	1
11	93006-0337	Coupling	1
12	91094-0253	Hex Bolt	2
13	23051-9050	Motor 12V	1
	23051-9060	Motor 24V	
	18753-0089	Service Kit	

MAINTENANCE

Check wires and connections to be sure corrosion is not adding additional resistance to the motor circuit and causing a low voltage condition at the motor. Full voltage should be available to prevent motor damage.

If pump is to be in freezing temperatures, drain by loosening end cover screws.

DISASSEMBLY

1. Disconnect pump from electrical supply.
2. Disconnect plumbing from pump.
3. Remove the 4 hexagon screws holding body to seal housing.
4. Partially withdraw body then push vanes into rotor, hold in position and remove body.
5. Mark the ends of the vanes and end of rotor to ensure that the vanes will be returned to their respective slots in rotor.
6. Loosen set screw on coupling (using an allen wrench). Locate screw through access hole in seal housing. Withdraw rotor and shaft assembly.
7. Remove hexagon head screws which secure seal housing to motor. Withdraw motor.
8. Inspect seal and shaft bushings for wear and only remove if necessary.
9. Vanes must be replaced when width has reduced to 7/16" (dimension when new - 1/2").

Motor Removal Only

1. Disconnect electrical supply.
2. Use allen wrench through access hole in seal housing to loosen set screw in coupling.
3. Remove 2 hexagon head bolts (key 12) which secure seal housing to motor and withdraw motor.

ASSEMBLY

1. Install new shaft bushings if required.
Note: If grooved shaft bushing is to be replaced, ensure that the groove is positioned opposite the groove in the inside face of the pump body. Both bushings must be flush or below the face of the pump body and seal housing.
2. Install new seal, if required. Ensure seal lip points toward bushing.
3. Grease bushing and lip of lip seal.
4. Carefully push rotor shaft through seal housing bushing and seal.
5. Install vanes into their respective slots. If new vanes are installed, radiused edges must be facing outwards.
6. Clean faces of body, seal housing and O-ring groove. Install O-ring.
7. Assemble body onto shaft and seal housing. Secure with hexagon screws and washers.
8. Check location of set screw in coupling.
9. Align flat in shaft with coupling set screw and slide seal housing/pump assembly over coupling/motor assembly. Insert rotor shaft into coupling and locate seal housing against motor face. Secure with screws and lock washers. Ensure spring coupling is not under pressure and tighten set screw.

ONE YEAR LIMITED WARRANTY

A. WARRANTY: ITT warrants that at the time of shipment, the products manufactured by ITT and sold hereunder shall be in conformity with applicable written specifications and descriptions referred to or set forth herein, free from defects in material and workmanship, merchantable, and suitable for a particular purpose, provided such is implied by State law under the circumstances of this sale.

B. WARRANTY ADJUSTMENT:

1. ITT agrees to repair or furnish a replacement for, but not to remove or install, any product or component thereof which, within one (1) year from date of purchase, shall upon test and examination by ITT prove defective within the above warranty. Receipt verifying purchase date is required to obtain adjustment.
2. Buyer shall notify ITT of any defect within this warranty no later than ninety (90) days after the defect is discovered.
3. No product will be accepted for return or replacement without the prior written authorization of ITT. Upon such authorization, and in accordance with instructions from ITT, the product will be returned to ITT, shipping charges prepaid by Buyer. Products returned to ITT will be addressed as follows:

ITT JABSCO PRODUCTS

1485 Dale Way

Costa Mesa, California 92626-3998

Or to such alternate locations as may be designated
on the product, its container, or this sheet.

Repair or replacement made under this warranty will be shipped prepaid to Buyer.

C. EXCLUSIONS FROM WARRANTY:

1. The foregoing warranty is limited solely as set forth herein and applies only for the period designated above.
2. ITT SHALL NOT BE LIABLE FOR ANY LOSS, DAMAGE, SPECIAL OR CONSEQUENTIAL DAMAGE OF ANY KIND, WHETHER BASED UPON WARRANTY, CONTRACT, NEGLIGENCE, OR STRICT LIABILITY ARISING IN CONNECTION WITH THE SALE, USE, OR REPAIR OF THE PRODUCT.
3. THE MAXIMUM LIABILITY OF ITT IN CONNECTION WITH THIS WARRANTY SHALL NOT IN ANY CASE EXCEED THE CONTRACT PRICE FOR THE PRODUCT CLAIMED TO BE DEFECTIVE OR UNSUITABLE.
4. This warranty does not extend to any product manufactured by ITT which has been subjected to misuse, neglect, accident, improper installation, or use in violation of instructions furnished by ITT.
5. This warranty does not extend to or apply to any unit which has been repaired or altered at any place other than ITT's factory, or by persons not expressly approved by ITT, nor to any unit the serial number, model number, or identification of which has been removed, defaced or changed.
6. Components manufactured by any supplier other than ITT shall bear only that warranty made by the manufacturer of that product.
7. This warranty applies to products defined as "consumer products" by the Consumer Product Warranties Act as from time to time amended.

STANDARD WARRANTY: If the products manufactured and sold hereunder are not Consumer Products, the warranty extended to Buyer shall be as set forth in subparagraphs (a), (b), and (c), EXCEPT THAT ALL EXPRESS OR IMPLIED WARRANTIES OR MERCHANTABILITY OR SUITABILITY FOR ANY PARTICULAR PURPOSE ARE EXCLUDED.

334 452-3425

ITT JABSCO
A Unit of ITT Corporation
1485 Dale Way, P.O. Box 2158
Costa Mesa, CA 92628-2158
Telephone: (714) 545-8251
4722035 ITTJABSCO CSMA
678357 ITTJABSCO CSMA