



23590 Hydraulic Oil Transfer Pump

6/00

23590 12/24V Transfer Pump

Features

- Self priming up to 1.8 metres
- Maximum differential pressure 1.5 bar
- Maximum flow - 26 l/min @ 0.5 bar diff pressure
- Suitable for hydraulic oil, etc up to 150 cSt
- Full range of installation accessories

Typical applications

- General transfer duties
- Pumping of hydraulic systems on vehicles in construction and forestry industries†



Specifications

Temperature Range : -20°C to +40°C

Pump Body : Aluminium

Rotor : Sintered Iron

Vanes : PTFE Filled Ryton

Shaft : Stainless Steel

Seal : Nitrile Lip Seal

Ports : Vertical 1/2" BSP or 19mm hose adaptors (3/4")

Motor : 12V or 24V DC permanent magnet, corrosion resistant IP44 protected

Duty : 30 mins @ +20°C 0.5 bar differential pressure
15 mins @ +20°C 1.0 bar differential pressure

Model Range

12v model, 1/2" BSP int, Iron	23590-2010
24v model, 1/2" BSP int, Iron	23590-2110
19mm Hose adaptor kit	23533-1100B

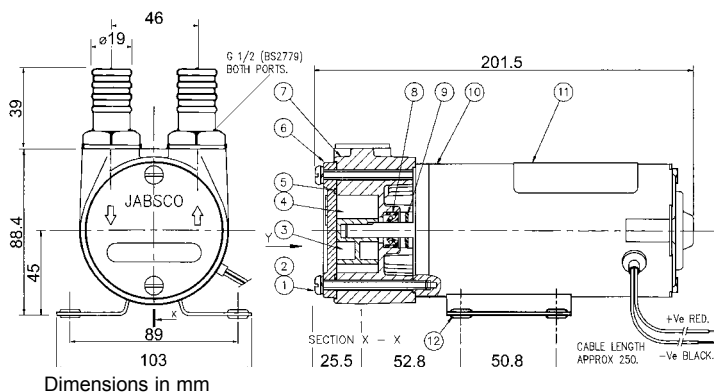

Parts List

Key	Description	Qty	Part No.
1	Screw	2	X3002-166C
2	Spring washer	2	SP1602-0240
3	Rotor*	1	23591-0000
4	Vane*	5	45716-0100
5	O-Ring*	1	X1990-131
6	Endcover	1	23875-0050
7	Body	1	23874-2060
8	Seal*	1	SP2701-52
9	Slinger*	1	6342
10	Motor	12 Volt	1 98012-9273
		24 Volt	1 98012-9272
11	Grommet	4	SP2900-12
12	Fuse Holder	1	X5501-018
13	Fuse	12V / 20A	1 SP2005-0120B
		24V / 10A	1 Y5292-02

Service kit contains items marked *

Service Kit	1	SK399-0201
-------------	---	------------

Note

All performance information is based on diesel fuel at 20°C (68°F). On production product, this may vary by up to 10%. Maximum recommended total head of diesel fuel is 6 metres.

Current Draw 12V = 17 Amps @ 0.5 bar diff/press
24V = 8 Amps @ 0.5 bar diff/press

Maximum Current 12V = 20 Amps
24V = 10 Amps

WARNING Explosion hazard. Do not pump gasoline, solvents, thinners or other flammable liquids. To do so can cause an explosion resulting in injury or death.



23590 Hydraulic Oil Transfer Pump

6/00

Installation, Operating, Service & Safety Instructions

Installation

- Mount pump horizontally, this position gives the best priming performance. If mounted vertically, motor should be uppermost.
- 19mm bore is the minimum hose size recommended.
- Do not mount pump, more than 1.5 metres above the liquid to be pumped. Maximum total head 3 metres. Avoid long pipe runs, 5 metres maximum.
- Do not pump debris, if there is a risk of particles, a suction strainer with mesh size of 500 microns should be used to protect the pump. Open area should be 1100mm².
- Electrical connections - Connect black wire to negative (-) supply (or earth of negatively earthed vehicles). The red wire to the positive (+) supply. This will ensure correct rotation. Ensure electrical supply is adequately rated for maximum amp draw and wiring is fused in line with recommendations.

Operating instructions

- Check direction of flow with the arrows on the pump, and position hoses accordingly.
- With suction hose immersed in liquid, switch on pump.
- If pump fails to prime within a few seconds, check the following:-
 - (1) There are no leaks on the suction side
 - (2) Battery is up to nominal voltage
 - (3) Fuse has not blown
 - (4) Maximum priming height has not been exceeded
- After liquid transfer, switch off pump. Observe maximum duty times.
- Dry running:- Pre-operational dry running should be limited to 30 seconds. Post operational dry running can be avoided if pump is mounted horizontally with ports uppermost. Sufficient liquid will be trapped in the pump to run for up to 20 minutes without damage, with no further incoming liquid.

Service instructions - Dismantling

- Disconnect electrical supply
- Remove pipe work and pump from its mounting.
- Remove endcover screws, gently slide body and endcover assembly from motor shaft and place on workbench with endcover uppermost. Remove endcover and O-ring, remove rotor and vanes. To remove seal turn body over, if there is no evidence of leakage leave lip seal in place, otherwise gently prise out with a screwdriver taking care not to damage seal bore.

Service instructions - Assembly

- Once pump has been dismantled O-ring must always be replaced. Replace vanes, rotor and seals if required.
- Clean all parts to remove any dirt or grit.

Note:- This pump rotates anti-clockwise, when viewed from pump end.

- (1) Push new seal into housing and grease lip.
- (2) Smear oil on shaft and slide on slinger.
- (3) Stand motor in a vertical position with shaft uppermost and fit body.
- (4) Fit rotor onto shaft (on pumps with metal rotor, it should be fitted with relief slot on trailing edge) and apply a few drops of oil into each slot.
- (5) Insert the five new vanes into the rotor slots with the radius on the leading edge.
- (6) Smear grease into the endcover O-ring groove and fit new O-ring.
- (7) Place endcover on body, secure with the two slotted screws and spring washers, through the body into the motor and tighten.

Safety warning

- Motor is not flame proof.
- Do not use for pumping petrol / gasoline, or products with flashpoints below 37°C
- Observe maximum duty times.
- Motor may become hot during use.
- Always use with a fuse fitted.
- Do not dry run.

Jabsco



ITT Industries

USA

Jabsco
1485 Dale Way
Costa Mesa
CA 92628-2158

Tel : +1 714 545 8251
Fax : +1 714 957 0609

UK

Jabsco
Bingley Road
Hoddesdon
Hertfordshire, EN11 0BU

Tel : +44 (0) 1992 450 145
Fax : +44 (0) 1992 467 132

GERMANY

Jabsco GmbH
Oststrasse 28
22844 Norderstedt

Tel : +49 (0) 40 53 53 73 0
Fax : +49 (0) 40 53 53 73 11