



MARCH PUMPS

1819 PICKWICK AVE., GLENVIEW, IL 60026-1306, U.S.A
PHONE: (847) 729-5300 - FAX: (847) 729-7062
WWW.MARCHPUMP.COM

INSTRUCTIONS & REPAIR PARTS FOR MODEL 210-5, 210-10, & 212 CORROSIVE SOLUTION “METL-LESS” PISTON METERING PUMPS

PUMP MATERIALS AND SOLUTIONS

The Metering pump was designed to meter a wide range of mild acids, caustics, solvents and any other liquids that will not affect Ryton® plastic, ceramic, viton “A” rubber, and Teflon®. These are the basic materials that come in contact with the liquid being pumped. Contact the factory for more specific information on the liquid and effect on the pump components. This pump is for intermittent duty only and should be flushed with clean water after use. The piston rings have a life expectancy of approximately 5000 hours. If leakage is observed past the piston, then the piston and arm assembly, item 5a, should be replaced.

ELECTRICAL AND OPERATION

The standard motor is 115 volts, 60 cycle, 1 phase A.C. shaded pole motor. The pump comes equipped with a SJT electric cord, 6 foot long with a 3 prong molded grounding type plug. Other cords can be furnished under special order. The 3600 RPM constant duty fan cooled gear motor with thermal overload protector is U.L. listed.

The pump should not be allowed to run dry for longer than 10 minutes as there is a possibility of damaging the plastic piston rings. The pump should have primed itself well within this time. If the pump has not primed itself within 10 minutes, something is wrong. Check for leakage around the threaded areas of the inlet and outlet pipefittings. It is recommended that you use Teflon sealing tape on the threads of your connection fittings. The pump will prime rapidly if some of the liquid is poured into the inlet and outlet ports. Once the valve and valve seats are wet there should be no problems priming, provided all the connections are airtight.

If the pump loses prime or does not repeat on flow rates or pressures, there may be dirt or other foreign matter between the valves and valve seats. This will prevent the valves from closing properly. Remove the two hexagon plugs on the front and side of the pump body and carefully pull out the two small valves. Check for dirt and damage to the valve faces and valve seats. March uses a patented magnetic repulsion action to actuate the valves. This prevents the need for valve springs and assures positive shut off of the valves.



MODEL 210-10

PUMP CONSTRUCTION & SERVICING

The flow can be varied while the pump is running. Loosen the whit thumb screw protruding through the front cover approximately ½ turn and then move your adjusting lever up or down until you get your desired flow. The scale is graduated from 0 flow to 100 percent flow and should be used as a reference guide only. Once a percentage of flow is achieved, you can move the lever, and as long as you come back to the same reference mark, your flow will repeat.

The 210 series pumps will develop approximately 160 PSI and 212 pump approximately 60 PSI. Care must be taken at these high pressures so as not to burst your fittings or tubing or not to stall out the motor. If you are going to use this pump at high pressures or through a small nozzle, you should provide a bypass or any other safety means to avoid clogging of the nozzle to prevent building excessive pressure.

LIMITED WARRANTY

March pumps are guaranteed only against defects in workmanship or materials for a period of one year from date of manufacture pumping water. On all other solutions, contact the factory for application assistance. March Pump Application Worksheet 750-130-10 is available for additional warranty information.

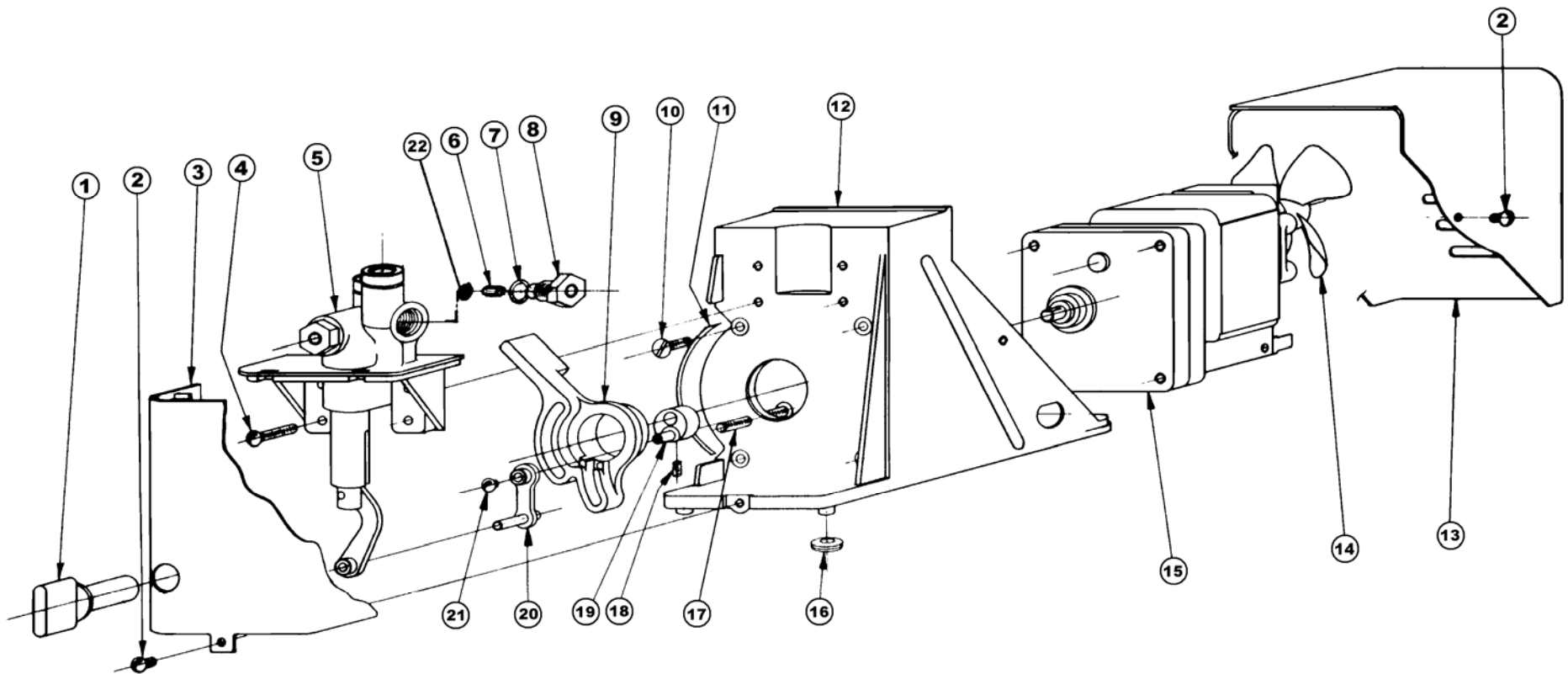

REPAIR PARTS LIST FOR MODEL 210-5R, 210-10R & 212 METERING PUMPS

ITEM	DESCRIPTION	QTY.	PART NO.	ITEM	DESCRIPTION	QTY.	PART NO.
PARTS COMMON TO ALL PUMPS				PARTS FOR 210 PUMPS			
1	Cam Wing Nut	1	0210-0001-1000	5	½ Diam. Pump Head & Piston Ass'y.	1	0210-0074-0200
2	No. 8-32 Round Head Screw	3	0135-0042-1000	5a	Piston & Arm Ass'y. only	1	0210-0073-0200
3	Front Cover	1	0210-0018-1000	6	Valve-Magnet Ass'y.	2	0210-0071-0100
4	No. 8-32 x ¼ Round Head Screw	4	0210-0036-1000	7	"O" Ring – Viton Rubber	2	0210-0008-1000
9	Adjustable Cam Drive	1	0210-0016-1000	8	Holding Screw – Magnet Ass'y.	2	0210-0025-0100
10	No. 10 Flat Head Screw	4	0212-0032-1000	15a	Motor for -10 (235 RPM) 115 Volt W/Fan	1	0212-0033-1000
11	Graduation Label	1	0210-0033-1000	15b	Motor for -5 (60 RPM) 115 Volt W/Fan	1	0212-0035-1000
12	Pump Housing Bracket	1	0210-0021-1000	22	Valve Disc – Viton Rubber	2	0210-0070-1000
13	Motor Cover	1	0210-0019-1000	PARTS FOR 212 PUMP			
14	C. W. Fan (As Spare Only)	1	0210-0026-1000	5	¾ Diam. Pump Head & Piston Ass'y.	1	0212-0008-0200
16	Rubber Leg Grommet	4	0410-0045-1000	5a	Piston & Arm Ass'y. Only	1	0212-0005-0200
17	No. 10 x 1 ¼ Flat Head Screw	1	0210-0029-1000	6	Valve-Magnet Ass'y	2	0212-0002-0100
18	No. 8 set Screw	1	0210-0038-1000	7	"O" Ring – Viton Rubber	2	0212-0017-1000
19	Motor Cam	1	0210-0080-0000	8	Holding Screw – Magnet Ass'y.	2	0212-0003-0100
20	Connecting Arm Ass'y.	1	0210-0004-0200	15	Motor for 212 (235 RPM) 115 Volt W/Fan	1	0212-0033-1000
21	Connecting Arm Screw	1	0210-0082-1000				