



MARCH PUMPS

1819 PICKWICK AVE., GLENVIEW, IL 60026-1306, U.S.A
 PHONE: (847) 729-5300 - FAX: (847) 729-7062
 WWW.MARCHPUMP.COM

809-HS "MAGNE-BOOST" HOT WATER PUMPS

DESCRIPTION:

Your March hot water booster pump is a non-self priming unit built to handle liquid transfer in heating and cooling operations. Applications include home heating systems, solar heating systems, heat recovery systems and recirculating water in domestic and commercial hot water tanks. Contact the factory for applications other than those listed, and for liquids other than water.

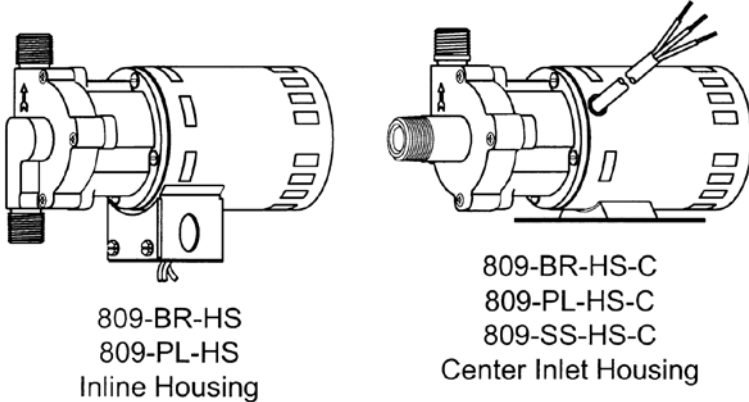

809-BR-HS
 809-PL-HS
 Inline Housing

809-BR-HS-C
 809-PL-HS-C
 809-SS-HS-C
 Center Inlet Housing

ABBREVIATIONS:

Pump Housing: BR is Bronze, PL is Polysulfone Plastic, SS is Stainless Steel, C is Center Inlet.

INSTALLATIONS:

The pump is assembled and ready for installation. The pump should be mounted with the Electric Conduit Box on the bottom. The oil ports will then be on the top of the motor. The pump housing should be installed with the arrow on our housing pointing in the direction of the water flow within the system. If the arrow indicating water flow is not in the direction you require when the motor is in position, remove the four round housing screws (Item 1) holding the housing to the motor assembly and rotate the housing assembly as required. Replace the four screws and tighten. The pump is made up of two basics sub-assemblies. They are the Wet End Assembly and the Motor/Bracket/Drive Magnet Assembly. To separate the 2 assemblies, simply remove the 4 round head screws (Item 1). The pump will then separate into the 2 sub-assemblies. The water will still be contained within the Wet End assembly unless you loosen the screws on the rear of the Wet End Assembly.

LUBRICATION:

The motor should be oiled at least once a year at the start of the heating season with 4 or 5 drops of SAE 20 weight non-detergent oil in each bearing. If the pump is used year around it should be oiled every six months. Do not over oil. No oiling is required on the ball bearing motors.

GENERAL SAFETY INFORMATION:

Follow all local electrical and safety codes, and the Occupational Safety and Health Act (OSHA). Make certain that the power source conforms to the requirements of your equipment. Always disconnect power source before performing any work on or near the electric motor. Caution must be exercised to relieve any pressure in the system and in draining hot water from the pump or the system.

*UL Recognition on pumps, file E80954, is for water only. Motors are U.L. Yellow Card listed, impedance protected or thermal overload Protected. Complete pump under U.L. file E80954.

California Law, Bill #1953, states that any item, which provides water for human consumption, shall contain no more than 0.2% lead. March cannot recommend the 809 series out of bronze; instead use the plastic or stainless steel housing.

NOTES:

All specifications & data are based on pumping water & are intended for use as a guideline only. Ratings & dimensions may vary depending on the current motor being used.

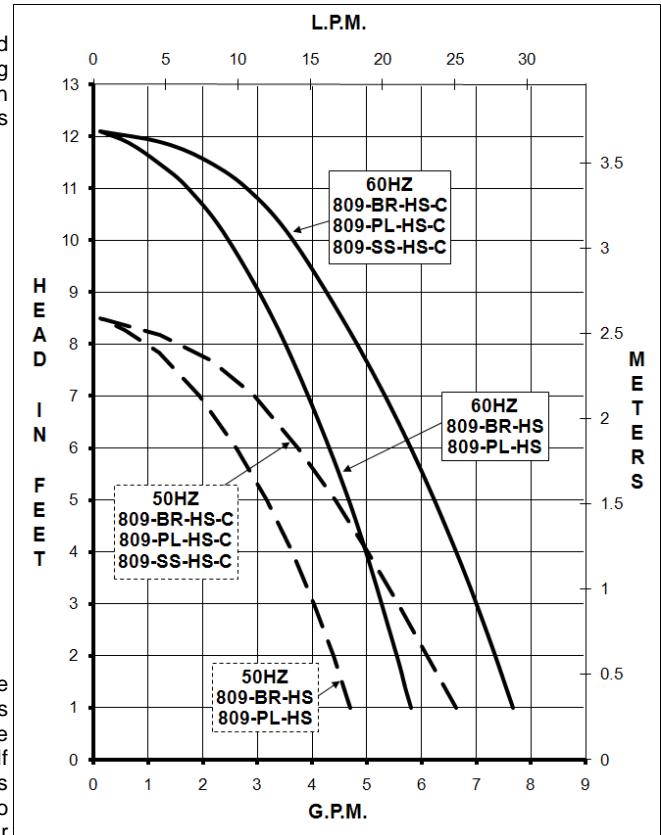

SPECIFICATIONS			809-BR-HS	809-PL-HS	809-BR-HS-C	809-PL-HS-C	809-SS-HS-C
Max Flow	50Hz	lpm	18.9	18.9	26.4	26.4	26.4
	60Hz	gpm	6	6	7.5	7.5	7.5
Max Head	50Hz	m	2.5	2.5	2.5	2.5	2.5
	60Hz	ft (psi)	12.1 (5.23)	12.1 (5.23)	12.1 (5.23)	12.1 (5.23)	12.1 (5.23)
Inlet			1/2" MPT	1/2" MPT	3/4" MPT	3/8" FPT & 3/4" MPT	3/4" MPT
	Outlet		1/2" MPT	1/2" MPT	1/2" MPT	1/2" MPT	1/2" MPT
Max Internal Pressure		psi	150	50	150	50	150
		bar	10	3.4	10	3.4	10
Max Liquid Temperature		°F	250	250	250	250	250
		°C	121	121	121	121	121
Packed Weight		kg/lbs	2.7/6	2.3/5	2.7/6	2.3/5	2.7/6
Motor Type			Air Cooled 115 or 230	Air Cooled 115 or 230	Air Cooled 115 or 230	Air Cooled 115 or 230	Air Cooled 115 or 230
Phase			1	1	1	1	1
50Hz	Volts	115 230	115 230	115 230	115 230	115 230	115 230
	Watts	100 104	100 104	109 110	109 110	109 110	109 110
	Amps	1.4 .7	1.4 .7	1.4 .7	1.4 .7	1.4 .7	1.4 .7
	Kw	.029 .029	.029 .029	.029 .029	.029 .029	.029 .029	.029 .029
	Rpm	2850 2850	2850 2850	2850 2850	2850 2850	2850 2850	2850 2850
	60Hz	Volts	115 230	115 230	115 230	115 230	115 230
Watts	87 90	87 90	97 101	97 101	97 101	97 101	
Amps	1.4 .7	1.4 .7	1.4 .7	1.4 .7	1.4 .7	1.4 .7	
Hp	1/25 1/25	1/25 1/25	1/25 1/25	1/25 1/25	1/25 1/25	1/25 1/25	
Rpm	3450 3450	3450 3450	3450 3450	3450 3450	3450 3450	3450 3450	
Electrical Connection			Conduit Box	Cord	Conduit Box	Cord	Cord
Overall Pump Dimensions (Inches)	Height	5.31 4.87	5.31 4.88	4.50 4.50	4.37 4.37	4.50 4.50	
	Width	3.33 3.33	3.38 3.38	3.50 3.50	3.50 3.50	3.50 3.50	
Overall Pump Dimensions (cm)	Height	13.4 12.3	13.4 12.3	11.4 11.4	11.0 11.0	11.4 11.4	
	Width	8.4 8.4	8.5 8.5	8.8 8.8	8.8 8.8	8.8 8.8	
Length		19.6 19.6	19.6 19.6	22.7 22.7	21.4 21.4	21.8 21.8	

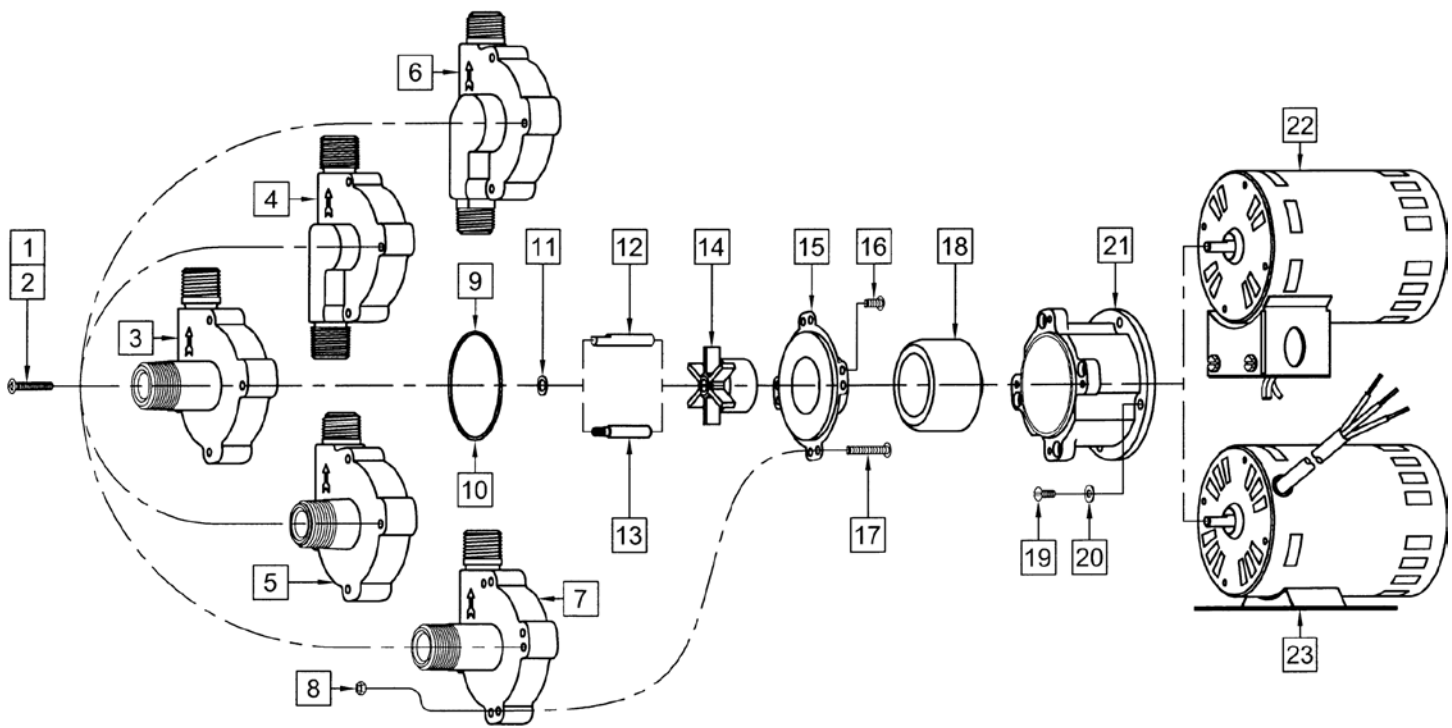

REPAIR PARTS LIST

ITEM	DESCRIPTION	MATERIAL	QTY	PART #	809-BR-HS	809-PL-HS	809-BR-HS-C	809-PL-HS-C	809-SS-HS-C
1	Screw #8-32 x 1" Long	Steel	4	0923-0003-1000	S	S	S	S	
2	Screw #8-32 x 1" Long	Stainless	4	0809-0205-1000					S
3	Pump Housing w/Center Inlet	Bronze	1	0809-0142-0000			S		
4	Pump Housing (Inline)	Bronze	1	0809-0013-0000	S				
5	Pump Housing w/Center Inlet	Polysulfone	1	0809-0179-0100				S	
6	Pump Housing (Inline)	Polysulfone	1	0809-0079-0100		S			
7	Pump Housing w/Center Inlet	Stainless	1	0809-0150-0000					S
8	Hex Nut	Stainless	4	0991-0004-1000					S
9	"O" Ring .070 CS x 2.441 ID	Silicone	1	0809-0165-1000	S		S		S
10	"O" Ring 1/16" CS x 2-3/8 ID	Silicone	1	0809-0027-1000		S		S	
11	Thrust Washer	Teflon	1	0809-0043-1000	S	S	S	S	S
12	Shaft	Stainless	1	0809-0161-1000	S	S	S	S	S
13	Shaft (Left-Hand Thread) (Old Style)	Stainless	1	0809-0008-1000	O				
14	Impeller (1-11/16" Dia.)	Ryton/Teflon/Carbon	1	0809-0005-0200	S	S	S	S	S
15	Rear Housing	Stainless	1	0809-0012-1000	S	S	S	S	S
16	Screw #8-32 x 3/8" Long	Stainless	4	0135-0040-1000	S	S	S	S	
17	Screw #8-32 x 1" Long	Stainless	4	0809-0205-1000					S
18	Drive Magnet		1	0125-0083-0100	S	S	S	S	S
19	Screw #8-32 x 3/8" Long	Stainless	4	0135-0040-1000	S	S	S	S	S
20	Washer	Stainless	4	0858-0004-1000	S	S	S	S	S
21	Motor Bracket	Plastic	1	0809-0058-1000	S	S	S	S	S
22	Motor 115V 50/60Hz		1	0809-0090-1000	S	S			
22A	Motor 230V 50/60Hz (Not Shown)		1	0135-0037-1000	S	S			
23	Motor 115V 50/60Hz		1	0809-0123-1000			S	S	S
23A	Motor 230V 50/60Hz (Not Shown)		1	0809-0124-1000			S	S	S

NOTE: Contact Factory for other materials and/or parts not listed.

Legend: S = Standard, O = Optional

DISASSEMBLY AND REASSEMBLY:

- 1—The motor can be removed from the Wet End assembly without having to drain the liquid out of the system.
- 2—Remove four screws (Item 1) and slide the motor assembly away from the Wet End assembly.
- 3—If you must replace parts inside the wet end assembly, then first close off the valves that supply water to the heating system or to the hot water tank. Drain the system to relieve any pressure.
- 4—After the system is drained and cool enough to handle, then remove the four screws on the rear of the housing.
- 5—The rear housing can now be removed. It may be snug fit into the pump housing and it may be necessary to pry evenly, under the four ears to loosen it.
- 6—Remaining pump parts can now be lifted out in sequence as shown on the exploded view. Replace any worn or damaged parts. Replace the "O" ring anytime the rear housing is removed.

LIMITED WARRANTY:

March pumps are guaranteed only against defects in workmanship or materials for a period of one year from date of manufacture pumping water. On all other solutions, contact the factory for application assistance. March Pump Application Worksheet 0750-0130-1000 is available for additional warranty information.