



MARCH PUMPS

1819 PICKWICK AVE., GLENVIEW, IL 60026-1306, U.S.A
PHONE: (847) 729-5300 - FAX: (847) 729-7062
WWW.MARCHPUMP.COM

INSTRUCTIONS & REPAIR PARTS FOR MODEL AB-F AND AB-FK

COMPONENTS LISTING AND FUNCTIONAL DESCRIPTION

The **Match AB-F Condensate Pump** is designed to be an automatic condensate removal pump for water dripping off an air conditioning evaporator coil. It is float-controlled, going "ON" when about 1" of water collects and going "OFF" when water level drops to 3/8" or lower. Connect pump to 115 volt, A.C. current – never to cycle with compressor, fan or time switch. Connect pump to its own power source. Model AB-F can be placed in evaporator drip pan, space permitting.

Motor draws 47 watts at 115 volts, 60 cycle.

Sump Pan is plastic and with square sides for mounting on side of furnace. On AB-FK only.

Check Valve is loosely screwed into the pump outlet on the AB-FK kits and comes with 1/4" male pipe thread for attaching to the pump outlet, and with 1/4" serrated connector for attaching the vinyl tubing. On AB-F pumps the check valve should be ordered as an extra if you feel a check valve is needed.

Vinyl Tubing is 20 ft. of 1/4" I.D. plastic tubing which is slipped on the Tube Connector and then extended to drain. If longer run is involved add additional tubing or a length of 1/4" O.D. tubing. Tubing furnished on AB-FK only.

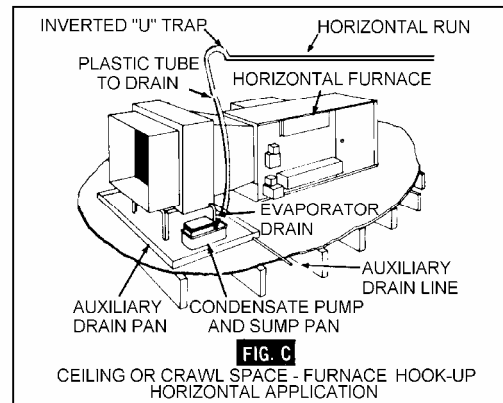
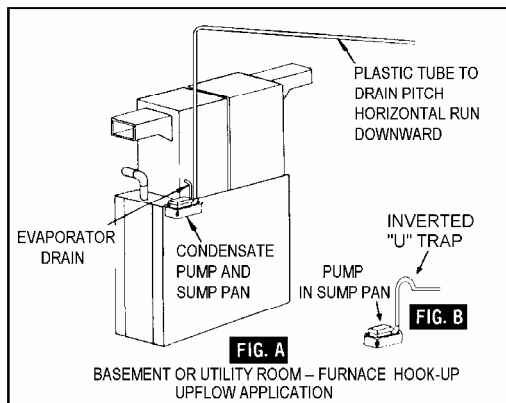

INSTALLATION INSTRUCTIONS FOR AB-FK KITS

1. Mount sump pan on side of furnace casing with (2) sheet metal screws (not furnished). Sump pan must be level for proper functioning of pump mercury switch.
2. Extend evaporator coil drain into sump pan with plastic pipe, tubing or rubber hose. (See illustration Fig A. above.) Horizontal run should be pitched for proper gravity flow. For further details, refer to instruction sheet, packed with evaporator coil.
3. Place pump in sump pan – must be level in both directions to assure full operating cycle. Tipped pump will short-cycle and will not operate at proper efficiency. Be sure that all four rubber grommets are on pump legs, on AB-FK Kits.
4. A plastic check valve with brass inserts is furnished with the AB-FK pump. The check valve should be cleaned at least once a year for proper operation. Screw fitting into pump outlet. Do not over tighten and crack the plastic discharge outlet.
5. Slip vinyl tubing onto check valve and run discharge line straight up, not to exceed ten feet. Pitch horizontal run tubing in a downward direction towards drain.
6. Run discharge line to floor drain, wash basin, toilet, laundry tub or other drain facility. Do not connect directly into plumbing soil stack.
7. Plug in electrical cord plug.
8. DRY TEST: Lift pump up and raise white float with fingertips. Pump should go "ON" with raised float and "OFF" when float is dropped. Do not tip pump while testing or mercury switch will act erratically.
9. WET TEST: Replace pump in sump pan (with 4 leg grommets in place). Pour one quart of water into pump pan. Pump will go "ON" and remove the water. Check all lines for leaks or kinks which will hamper water drainage.
10. Check sump periodically for dust, foreign matter or lint and clean as provided in "Cleaning Procedure," on next page.

AB-F and AB-FK Parts List

KEY NO.	DESCRIPTION	PART NO.	KEY NO.	DESCRIPTION	PART NO.
1	Pump complete, less accessories	0410-0001-0100	10	Impeller Cover Screw, 7 required	0410-0078-1000
2	Top Cover	0410-0002-1000	11	Top Cover Screw, 4 required	0410-0078-1000
3	Impeller with Screw and Washer	0410-0054-0100		PUMP ACCESSORIES	
4	Bottom Cover	0410-0004-1000	†	Check Valve Fitting	0410-0128-0100
5	Float Rod and Float Assembly	0410-0017-0100	†	Rubber Foot Pad, 4 required	0410-0045-1000
6	Float Rod Retainer Ring, 2 required	0410-0007-1000	†	Plastic Sump Pan	0410-0062-1000
8	Mercury Switch	0410-0022-1000	†	Vinyl Tubing, 20 ft. roll ¼" I.D.	0410-0024-1000
9	Mercury Tube	0410-0014-1000			

† Not Illustrated

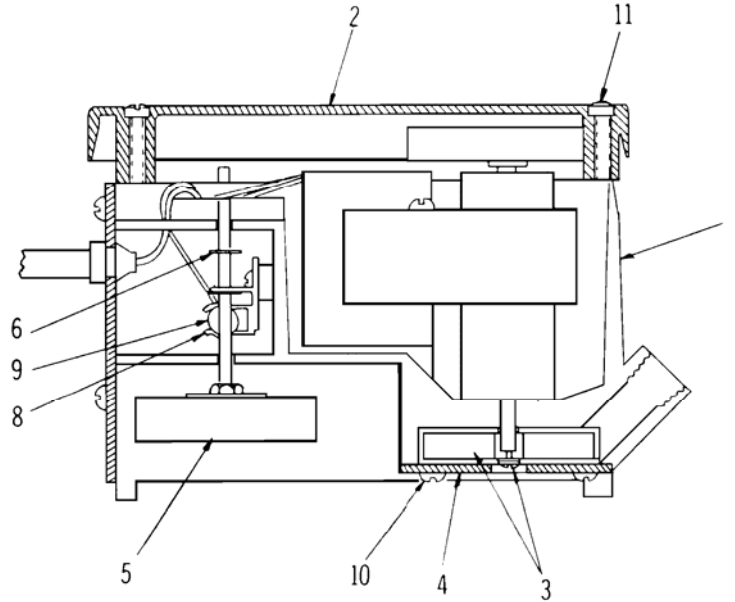

CLEANING PROCEDURE

Since condensate pumps are used only seasonally and do not run during winter months, it is recommended that the following cleaning procedure be employed before pump is re-activated each spring.

1. Disconnect power plug.
2. Disconnect discharge outlet, lift out pump and clean sump pan. Check and clean pump outlet, discharge line, and check valve.
3. Remove impeller cover screws (7 each) and clean impeller cavity. Four air bleed holes are located in ceiling of impeller cavity. If these are plugged, clean out with paper clip or pin. Air bleed hole in front of pump (next to discharge port) should be cleaned.
4. Remove cord plate to expose float rod and float switch assembly. If clean, skip paragraph (5) procedure.
5. Check float rod for free movement. Push up and down with fingers. If it should be sticky or gummed up, clean with solvent or detergent. Do not remove float rod retainer rings. If accidentally slipped off, re-install in original groove. These rings control length of pump cycle.
6. If float is dirty, twirl it on a detergent soaked cloth. Wipe carefully so that bottom of float is not sticky.
7. Re-assemble and connect pump. Repeat DRY TEST and WET TEST procedure set up in Installation Instructions (paragraph 8 and 9). Pump is now ready for a new season.



MARCH

MANUFACTURING INC.

1819 PICKWICK AVE., GLENVIEW, IL 60026-1306, U.S.A
 PHONE: (847) 729-5300 · FAX: (847) 729-7062 · www.marchpump.com

0410-0107-1000 R9