

# SRM4

4/10 Horsepower  
Residential Sewage Pump



**T**HE SRM4 MINI NON-CLOG PUMP IS THE MOST RELIABLE 4/10 HORSEPOWER RESIDENTIAL SEWAGE PUMP AVAILABLE TODAY. The SRM4 is a plumbers/contractors dream ... it will not clog! Its recessed impeller design allows 2" solids to pass freely through the volute without the chance of jamming the impeller. The SRM4 series pump has a national field-proven record of reliability. Look to your Myers distributor for the answer to your residential sewage handling needs ... and across the counter will be the Myers mini non-clog, the SRM4. It works for you! For more information, call your Myers distributor today, or the Myers Ashland, Ohio sales office at 419/289-1144.

## ADVANTAGES BY DESIGN

### DURABLE MOTOR WILL DELIVER MANY YEARS OF RELIABLE SERVICE.

- Oil-filled motor for maximum heat dissipation and continuous bearing lubrication.
- Overload protected shaded pole motor eliminates starting switches.
- Recessed vortex impeller provides minimal radial loading for long bearing life.

### THE SRM4P IS ENGINEERED FOR MANY YEARS OF MAINTENANCE-FREE OPERATION.

- Wide-angle piggy-back float switch for maximum draw down. (Automatic models)
- Pump can be operated manually by unplugging piggy-back switch and plugging pump directly into outlet (Automatic models).
- Recessed vortex impeller operates completely out of volute and provides free flow through passage for solids and liquids.

## PRODUCT CAPABILITIES

Capacities To	95 gpm	360 lmp
Heads To	18 ft. 19 ft. shutoff	5.5 m 5.8 m
Pump Down Range Float Switch	7 to 14 in.	178 to 356 mm
Solids Handling Capacity	2 in.	50.8 mm
Liquids Handling	raw sewage, effluent, drain water	
Intermittent Liquid Temp.	up to 140°F	up to 60°C
Motor	4/10 HP shaded pole 1550 RPM	
Electrical	115V, 12A or 230V, 6A, 1Ø, 60 Hz.	
Acceptable pH Range	5 - 9	
Discharge, NPT	2 in.	50.8 mm
Minimum Sump Diameter	Simplex Duplex	18 in. 30 in.
		457 mm 762 mm
ETL Listing	Class 1, Div. 2 Group D Class 2, Div. 2 Group F, G Class 3, Div. 1, 2	

Construction Materials	
Motor Housing	cast iron, Class 30, ASTM A48
Volute Case	cast iron, Class 30, ASTM A48
Impeller	recessed, thermoplastic
Power Cord	20 ft. 16/3 SJTW/SJTW-A
Mechanical Seal	carbon and ceramic

WHERE INNOVATION MEETS TRADITION

# SRM4

4/10 Horsepower  
Residential Sewage Pump

## MECHANICAL FLOAT SWITCH

Mercury-free, 90° angle operation. (Piggyback models only).

## 4/10 HP MOTOR

Pressed in place and Oil-filled for best alignment and heat transfer. Built-in overload protection.

## DUAL THRUST WASHERS, SLEEVE BEARINGS

Oil lubricated, enhance smooth operation and extend pump life.

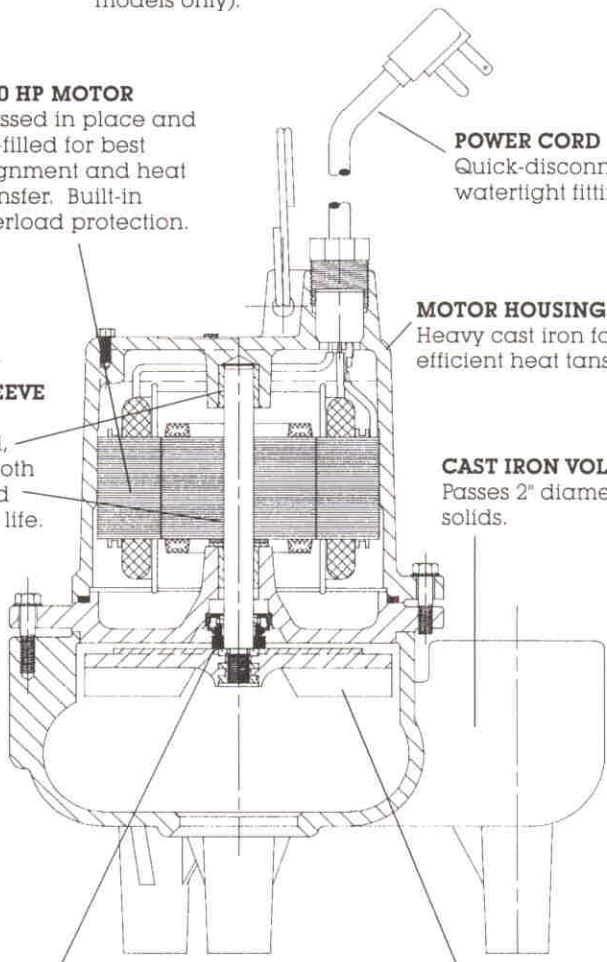

## POWER CORD

Quick-disconnect watertight fitting.

## MOTOR HOUSING

Heavy cast iron for efficient heat transfer.

## CAST IRON VOLUTE

Passes 2" diameter solids.

## MECHANICAL SHAFT SEAL

Carbon and ceramic faces, body is stationary, prevents string or trash from winding on seal.

## RECESSED IMPELLER

Operates out of volute passage, allowing maximum flow of liquids and solids.

## DIMENSIONS

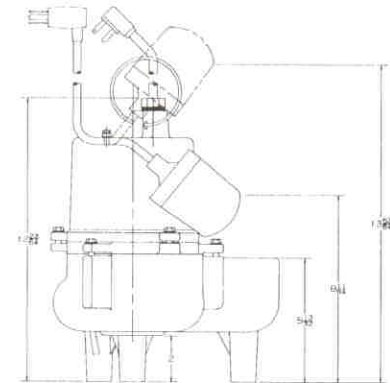
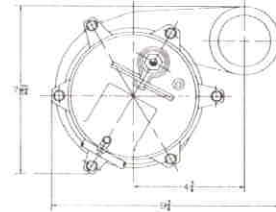

## PERFORMANCE CURVE

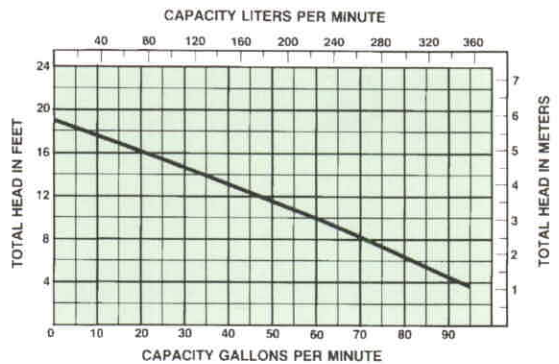

K3305 10/01  
Printed in U.S.A.



# Myers®

Pentair Pump Group

F. E. Myers, 1101 Myers Parkway, Ashland, Ohio 44805-1969  
419/289-1144, FAX: 419/289-6658, [www.femyers.com](http://www.femyers.com)

Myers (Canada), 269 Trillium Drive, Kitchener, Ontario N2G 4W5  
519/748-5470, FAX: 519/748-2553

# Myers®

Pentair Pump Group

## SSM33/SSM33I/SRM4 Series Submersible Sump, Effluent & Sewage Pumps

Safety Instructions  
Installation & Service Manual

Automatic and manual models. Single phase power only - 115 or 230 volt.

---

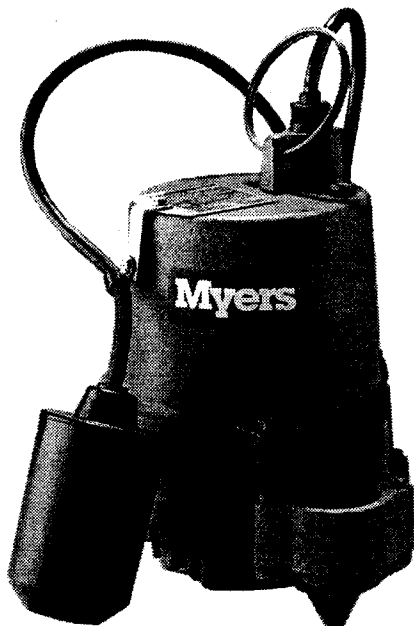

**SSM33I**  
**SUMP/EFFLUENT PUMPS**  
(115 Volt-Single Phase Only)

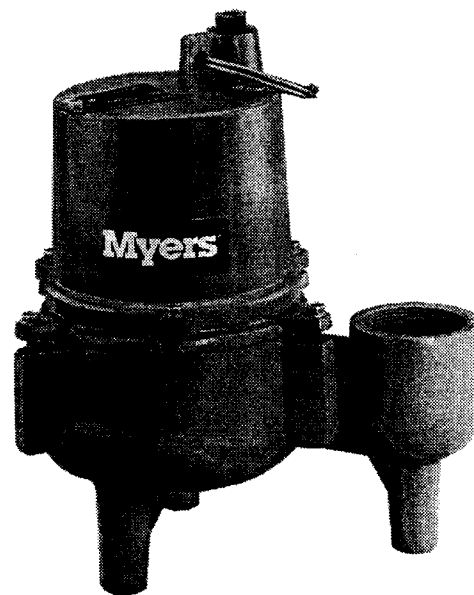

**SRM4**  
**SUMP/EFFLUENT/SEWAGE PUMPS**  
(115 or 230 Volt-Single Phase)

\*The SSM33 series pumps have been replaced by the SSM33I series pump as of February 2000.

# TYPICAL SECTION DRAWING FOR SSM33/SSM33I SERIES

②① Piggy-Back Control  
Control Vertical Float Switch  
10' Cord  
Control Vertical Float Switch  
20' Cord. Not Shown  
(Automatic Only)

②① Cable Tie. Not Shown  
(Automatic Only)

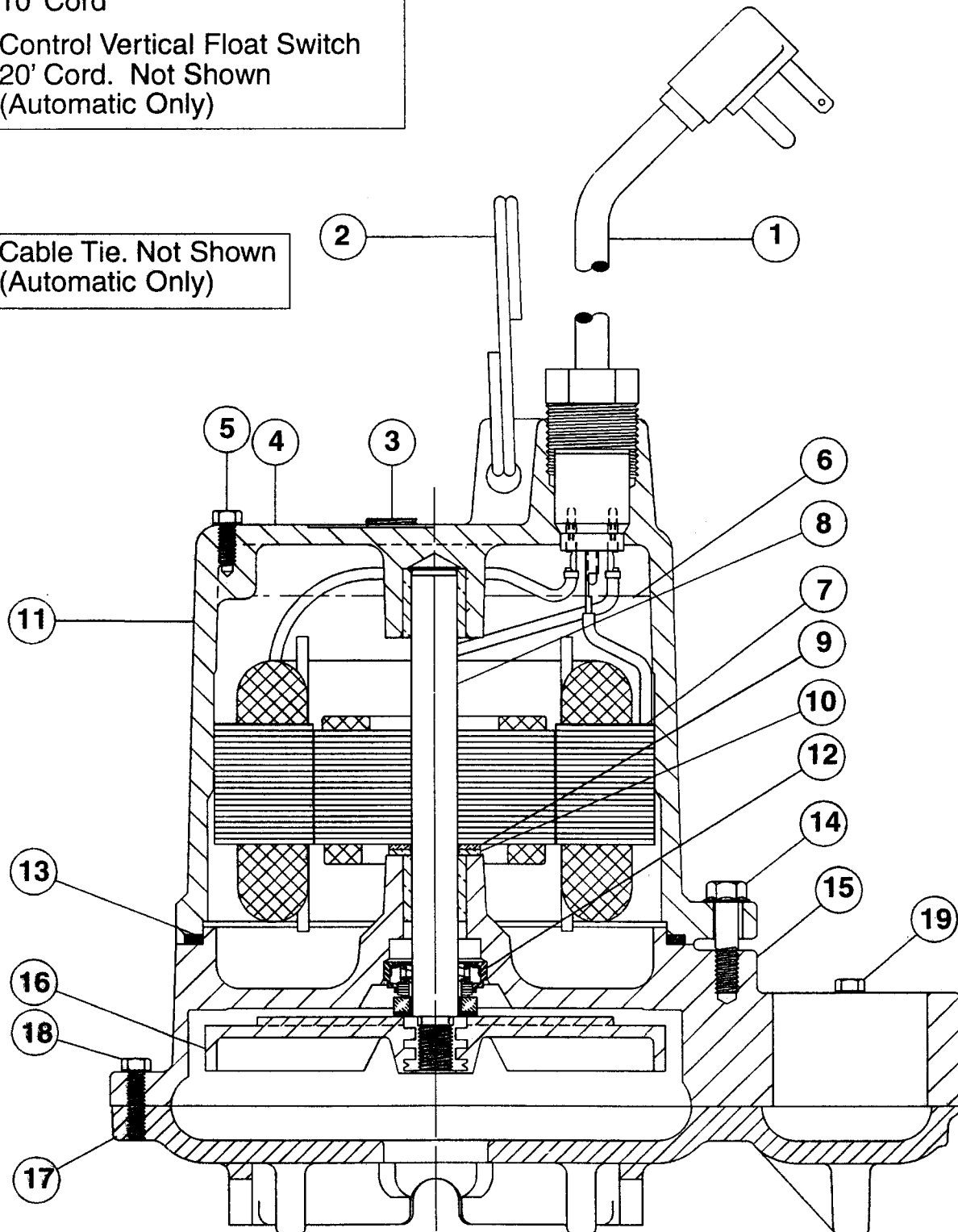

# TYPICAL SECTION DRAWING FOR SRM4 SERIES

- ②① Piggy-Back Control
- ②① Cable Tie  
Not Shown  
(Automatic Only)

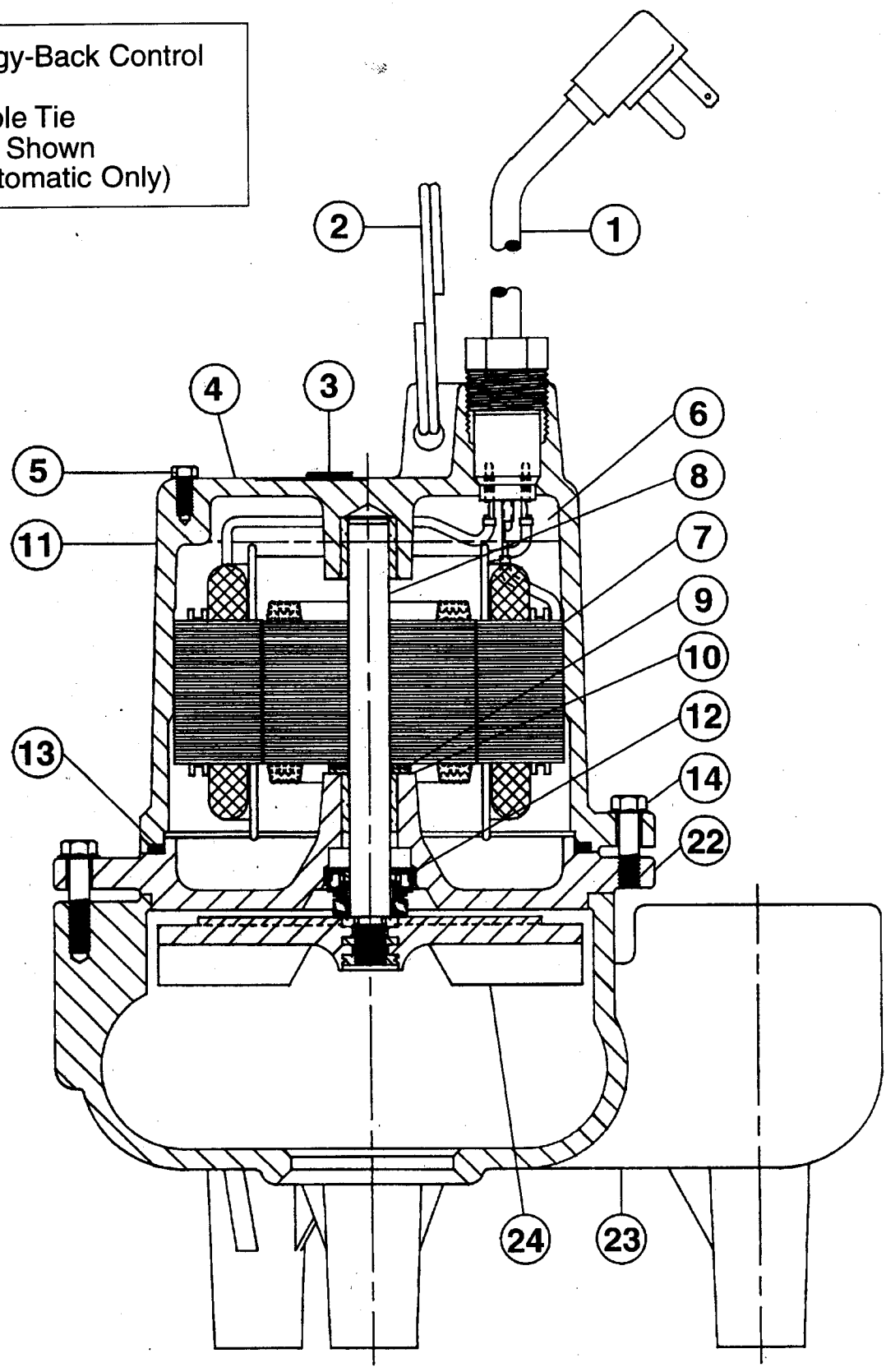

## PARTS LIST SSM33/SSM33I AND SRM4

Ref No.	No. Description	Part Req'd	Numbers
2	Ring, Lift	1	26230A000
3	Plug, 1/4" NPT	1	05022A056
4	Plate, Name (Not Stamped)	1	23780A000
5	Tapping, Screw (SSM33/SSM33I)	1	09822A032
5	Tapping, Screw (SRM4P Auto.)	1	09822A006
5A	Screw, Cap #10 x 3/4 Vertical Float Switch	2	18475A004
6	Oil, Transformer (1 Qt. In Can)	1	11009A002
8	Rotor with Shaft (SSM33/SSM33I)	1	22821A010
8	Rotor with Shaft (SRM4)	1	22821A000
9	Washer, Thrust, SST	1	05030A243
10	Washer, Thrust, Graphite	1	05030A244
11	Housing, Motor	1	23770D002
	Housing w/Stator 115V (SRM4P) 230V (SRM4P) 115V (SSM33/SSM33I)		23770D060K 23770D061K 23770D062K
12	Seal, 1/2" Shaft	1	21607A001
13	Gasket, Rubber	1	05014A172
14	Screw, Cap, 1/4-20 x 7/8 Lg. (SSM33/SSM33I) (SRM4)	3 6	18475A003 18475A003
15	Case, Volute (SSM33)	1	23771D001
15	Case, Volute (SSM33I)	1	23771D101
16	Impeller (SSM33)	1	22370B000
16	Impeller (SSM33I)	1	084980031

Ref No.	No. Description	Part Req'd	Numbers
17	Plate, Bottom, with Volute Case	1	27005D000
18	Screw, Tapping, #10 x 1" Lg. (SSM33, SRM4)	3	09822A036
18	Screw, Tapping, #10 x 3/4" Lg. (SSM33I)	3	18475A008
19	Screw, Tapping, #10 x 1 1/4" Lg. (SSM33, SRM4)	3	09822A040
19	Screw, Tapping, #10 x 1 5/8" Lg. (SSM33I)	3	18475A009
20	Control, Level, 115V, 10' Piggy-Back Float Switch	1	21813B130
20	Control, Level, 115V, 20' Piggy-Back Float Switch	1	21813B131
20	Control, Level, 230V, 10' Piggy-Back Float Switch	1	21813B132
20	Control, Level, 230V, 20' Piggy-Back Float Switch	1	21813B133
20	Vertical Control Switch - 10' Cord	1	26292B140
20	Vertical Control Switch - 20' Cord	1	26292B141
20A	Mounting Bracket, Control Switch	1	26291B010
21	Tie, Cable	1	17190A008
22	Plate, Seal (SRM4)	1	23773D002
23	Case, Volute (SRM4)	1	21612D000
24	Impeller (SRM4)	1	21610B000
Not Shown	Bracket, Float (SSM33/SSM33I)	1	24003A000

## CHART

Pump Catalog Number	Pump Engineering Number	Pump Type	HP	V	Ph	① Cord, Electric	Cord Length	⑦ Stator Only	Winding Resistance in Ohms	Max. Amps	Locked Rotor Amps
SSM33M1C*	26235D000	Manual	1/3	115	1	21628B048	20'	25757B010	1.3	8.0	12.5
SSM33P-1*	26235D010	Automatic	1/3	115	1	21628B046	10'	25757B010	1.3	8.0	12.5
SSM33PC-1*	26235D011	Automatic	1/3	115	1	2128B048	20'	25757B010	1.3	8.0	12.5
SSM33PV1*	26235D020	Automatic	1/3	115	1	21628B046	10'	25757B010	1.3	8.0	12.5
SSM33PV1C*	26235D021	Automatic	1/3	15	1	21628B048	20'	25757B010	1.3	8.0	12.5
SSM33IM1C*	26235D100	Manual	1/3	115	1	21628B048	20'	25757B010	1.3	9.0	12.5
SSM33IP-1*	26235D110	Automatic	1/3	115	1	21628B046	10'	25757B010	1.3	9.0	12.5
SSM33IPC-1*	26235D111	Automatic	1/3	115	1	2128B048	20'	25757B010	1.3	9.0	12.5
SSM33IPV1*	26235D120	Automatic	1/3	115	1	21628B046	10'	25757B010	1.3	9.0	12.5
SSM33IPV1C*	26235D121	Automatic	1/3	115	1	21628B048	20'	25757B010	1.3	9.0	12.5
SRM4M-1	26236D000	Manual	4/10	115	1	21628B046	10'	21599B026	1.2	12.0	16.0
SRM4M1C	26236D001	Manual	4/10	115	1	21628B048	20'	21599B026	1.2	12.0	16.0
SRM4M-2	26236D002	Manual	4/10	230	1	21628b047	10'	21599B027	4.3	6.0	8.2
SRM4M-2L/P	26236D004	Manual	4/10	230	1	21628B047	10'	21599B027	4.3	6.0	8.2
SRM4M2C	26236D003	Manual	4/10	230	1	21628B049	20'	21599B027	4.3	6.0	8.2
SRM4M-2CL/P	26236D005	Manual	4/10	230	1	21628B049	20'	21599B027	4.3	6.0	8.2
SRM4P-1	26236D010	Automatic	4/10	115	1	21628B046	10'	21599B026	1.2	12.0	16.0
SRM4PC-1	26236D011	Automatic	4/10	115	1	21628B048	20'	21599B026	1.2	12.0	16.0
SRM4P-2	26236D012	Automatic	4/10	230	1	21628B047	10'	21599B027	4.3	6.0	8.2
SRM4PC-2	26236D013	Automatic	4/10	230	1	21628B049	20'	21599B027	4.3	6.0	8.2

**NOTE: READ THESE INSTRUCTIONS CAREFULLY BEFORE ATTEMPTING TO INSTALL PUMP.**

**DESCRIPTION AND APPLICATION**

**SSM33, SSM33I and SRM4**

Myers SSM33, SSM33I and SRM4 Series Pumps are single seal units, available in automatic or manual. The SSM33 and SSM33I series pumps are designed for normal sump and dewatering, and can also be used in effluent applications. When used in effluent dosing or S.T.E.P. applications, the pump must be installed in a separate tank or compartment at the discharge side of the septic tank. **NEVER INSTALL PUMP IN MAIN TANK WHERE SLUDGE COLLECTS. DO NOT USE THE SSM33 OR SSM33I PUMP SERIES FOR RAW SEWAGE.** The SRM4 series pumps are designed for residential sewage and dewatering applications where a larger solid size is required.

**General**

The SSM33, SSM33I and SRM4 pumps use shaded pole, 1550 RPM motors. SSM33 and SSM33I are available in 115 volt only and the SRM4 is available in 115 or 230 volt and all are single phase only. Both the manual and automatic models come standard with a 10 ft. power cord. A 20 ft. cord and switch length are optionally available. All automatic models come with a mechanical (mercury free) piggy-back float switch or a vertical float switch. The SSM33 and SSM33I pumps are designed to handle 1/2" spherical solids and have a 1-1/2" NPT discharge threading. The SRM4 pumps are designed to handle 2" spherical solids and have a 2" NPT discharge threading. The SSM33, SSM33I and the SRM4 use an engineered thermoplastic vortex impeller designed to efficiently produce the required pressures and flows.

**WARNING! THESE PUMPS ARE NOT APPROVED FOR, AND SHOULD NOT BE USED IN SWIMMING POOLS, FOUNTAINS OR PUMPING POTABLE (DRINKING) WATER.**

**AIR LOCKING**

A pump is said to be air locked if water traps air in the pump and it cannot get out, thus preventing the pump from operating.

The SSM33, SSM33I and SRM4 sump pumps have a 1/16" air vent hole in the impeller chamber to let out trapped air. If this hole becomes plugged, pump may air lock. As a secondary precaution a 1/8" hole should be drilled in the discharge pipe below the check valve. The check valve should be 12 to 18 inches above pump discharge. Do not put check valve directly into pump discharge opening.

**PACKAGING**

Each pump is packaged separately in a carton marked with a catalog number and Myers engineering number. The pumps are carefully packaged to prevent damage in shipping. However, occasionally damage may result due to rough handling. Carefully go over the pump and check for damage that could cause the pump to fail.

**LEVEL CONTROLS**

The automatic models come with 10' or 20' power cord and mechanical (mercury free), piggy-back float switch. The 115 or 230 volt piggy-back switch is tethered directly to the pump. The switch can optionally be mounted to the discharge pipe using a minimum 3-5/8" tether length. The switch must float free from pump and basin wall. Plug the switch cord plug into a properly grounded, rated voltage receptacle. Plug the power cord into the back of the switch cord and tape the cords to the discharge pipe every 12". The power receptacle must be located outside the wet sump or basin due to the DANGER of current leakage.

On all duplex units or simplex installations with additional options like high water alarm, the power cord plug must be cut off and wired into a control panel or into a sealed junction box if used in wet sump or basin. The AWS-1 control also acts as a sealed junction box for connecting power cord to pump cord.

**DESIGN OF PRESSURE SEWER SYSTEMS**

Myers has available complete computer SOFTWARE for designing PRESSURE SEWER SYSTEMS. This gives pipe sizes to use and gives exact flow from any pump or group of pumps in the system when operating simultaneously.

This design DISK for IBM® or COMPATIBLE computers is available to engineers on request.

**MOTOR TYPE**

The motors used in these pumps are pressed into the cast iron housings and surrounded by dielectric oil for superior heat transfer. Both models use a shaded pole, 1550 RPM motor. The SSM33 and SSM33I are rated at 1/3 HP and the SRM4 is rated at 4/10 HP. All units have class A motor insulation. SSM33 and SSM33I are available in 115 volt, single phase only and SRM4 is available in 115 or 230 volt, single phase. All have overload protection, and use a double sleeve bearing design. These pumps have no starting switches and do not require a control panel for simplex installation.

**SAFETY WARNINGS**

**WARNING:** Risk of electric shock. Pumps are supplied with a grounding conductor and grounding-type attachment plug on the power cord. To reduce the risk of electric shock, be certain that it is connected only to a properly grounded, grounding-type receptacle. DO NOT cut off ground pin or use an adapter fitting. DO NOT use an extension cord with this pump.

All pumps have a GROUND WIRE that is connected to the motor. This wire goes to the receptacle or control panel which must be connected to a good outside GROUND.

When wiring this pump follow all local electrical and safety codes and ordinances as well as the most recent National Electric Code (NEC-ANSI/NFPA 70).

**UL AND CSA APPROVAL**

All pumps have UL and CSA approval pending. Myers is a SSPMA certified pump member.

## INSTALLATION

**WARNING:** Basin or tank must be vented in accordance with local plumbing codes. These pumps are not designed for and **CANNOT** be installed in locations classified as hazardous in accordance with the National Electric Code ANSI/NFPA 70.

**CAUTION:** Never enter pump chamber after sewage or effluent has been in basin. Sewage water can give off methane, hydrogen sulfide and other gasses which are highly poisonous. For this reason, Myers recommends installing effluent pumps with a quick removal system. The quick removal system may be a union or Cam-lok® coupling if the pipe or discharge hose is within reach from the surface, or a rail system type quick disconnect on deeper installations. See installation drawings for suggested installation.

The dosing tank or pumping chamber must be constructed of corrosion resistant materials and must be capable of withstanding all anticipated internal and external loads. It also must not allow infiltration or exfiltration. The tank must have provisions for anti-buoyancy. Access holes or covers must be adequate size and be accessible from the surface to allow for installation and maintenance of the system. Access covers must be lockable or heavy enough to prevent easy access by unauthorized personnel. The pumping chamber holding capacity should be selected to allow for emergency conditions.

The discharge pipe must be the same size as the pump discharge 1-1/2" for SSM33 and SSM33I, 2" for SRM4 or larger. In order to insure sufficient fluid velocity to prevent any residual solids from collecting in the discharge pipe, it is recommended that a minimum flow of 2' per second be maintained. (12 GPM through 1-1/2" pipe, 21 GPM through 2" pipe and 46 GPM through 3" pipe). It is recommended that PVC or equal pipe is used for corrosion resistance. A full flow (ball or gate) shut off valve must be installed to prevent back flow of effluent if the pump must be removed for service. A check valve must be installed on pressure sewer systems and on other systems where conditions allow to prevent backflow and to reduce wear on the pump system.

A high water alarm must be installed on a separate circuit from the pump circuit. The alarm should have the ability to be tested for proper operation.

## POINTS TO CHECK IF PUMP DOES NOT RUN OR DOES NOT RUN PROPERLY

- (1) **Pump does not run or start when water is up in tank.**
  - (a) Check for blown fuse or tripped circuit breaker.
  - (b) Check for defective level switch
  - (c) Where control panel is used be sure H-O-A switch is in the AUTO position. If it does not run, turn switch to the HAND position and if the pump runs then the trouble is in the automatic electrical system. Have ELECTRICIAN make electrical checks.
  - (d) Check for burned out motor. Occasionally lightning can damage a motor even with lightning protection.
  - (e) Where plug-in cords are used be sure contact blades are clean and making good contact. **DO NOT USE PLUG-IN CORDS INSIDE A SUMP OR WET WELL.**
  - (f) Level control ball or weight may be stuck on side of basin. Be sure it floats freely.
- (2) **Pump runs but does not deliver flow.**
  - (a) Check for airlock. Start and stop pump several times, if this does not help it may be necessary to loosen a union in the discharge line to relieve airlock.
  - (b) Check valve may be installed backwards. Check flow arrow on valve body. Check shut-off valve. It may be closed.
  - (c) Check vertical elevation. It may be higher than pump can develop. (See pump curve).
  - (d) Pump inlet may be plugged. Remove pump to check.

**CAUTION: ALWAYS UNPLUG POWER CORDS OR TURN OFF ALL MAIN AND BRANCH CIRCUIT BREAKERS BEFORE DOING ANY WORK ON THE PUMP.** If control panel is remote from pump, disconnect lead wires to motor so that no one can turn the circuit breaker back on.

## BEFORE DISMANTLING PUMP FOR REPLACEMENT OF PARTS

Clean pump thoroughly. Knock off all scale and deposits. Submerge complete unit on Clorox solution for one hour before taking apart.

# TYPICAL SUMP INSTALLATION FOR SSM33/SSM33I Series

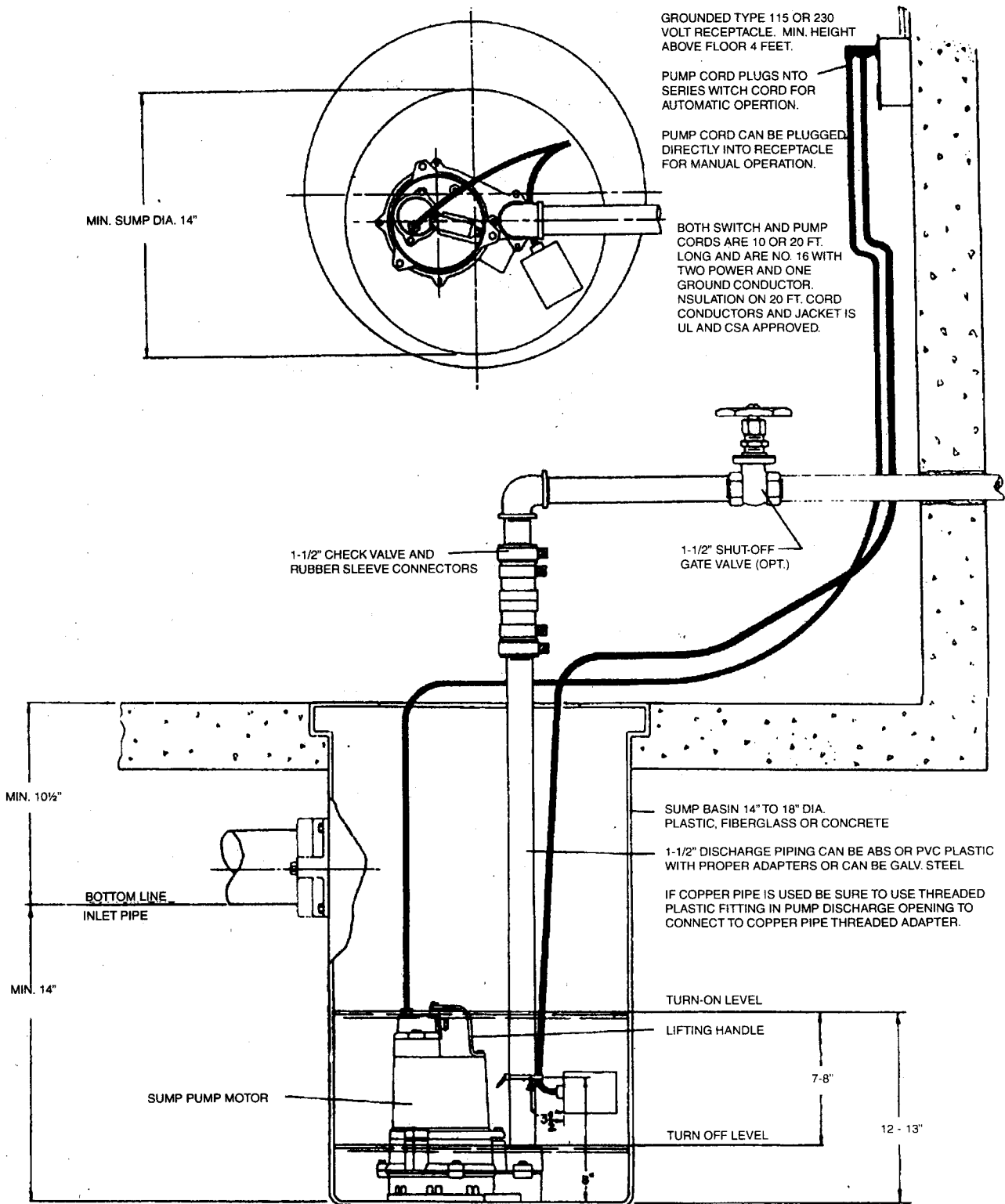

# TYPICAL SUMP INSTALLATION FOR SRM4 SERIES

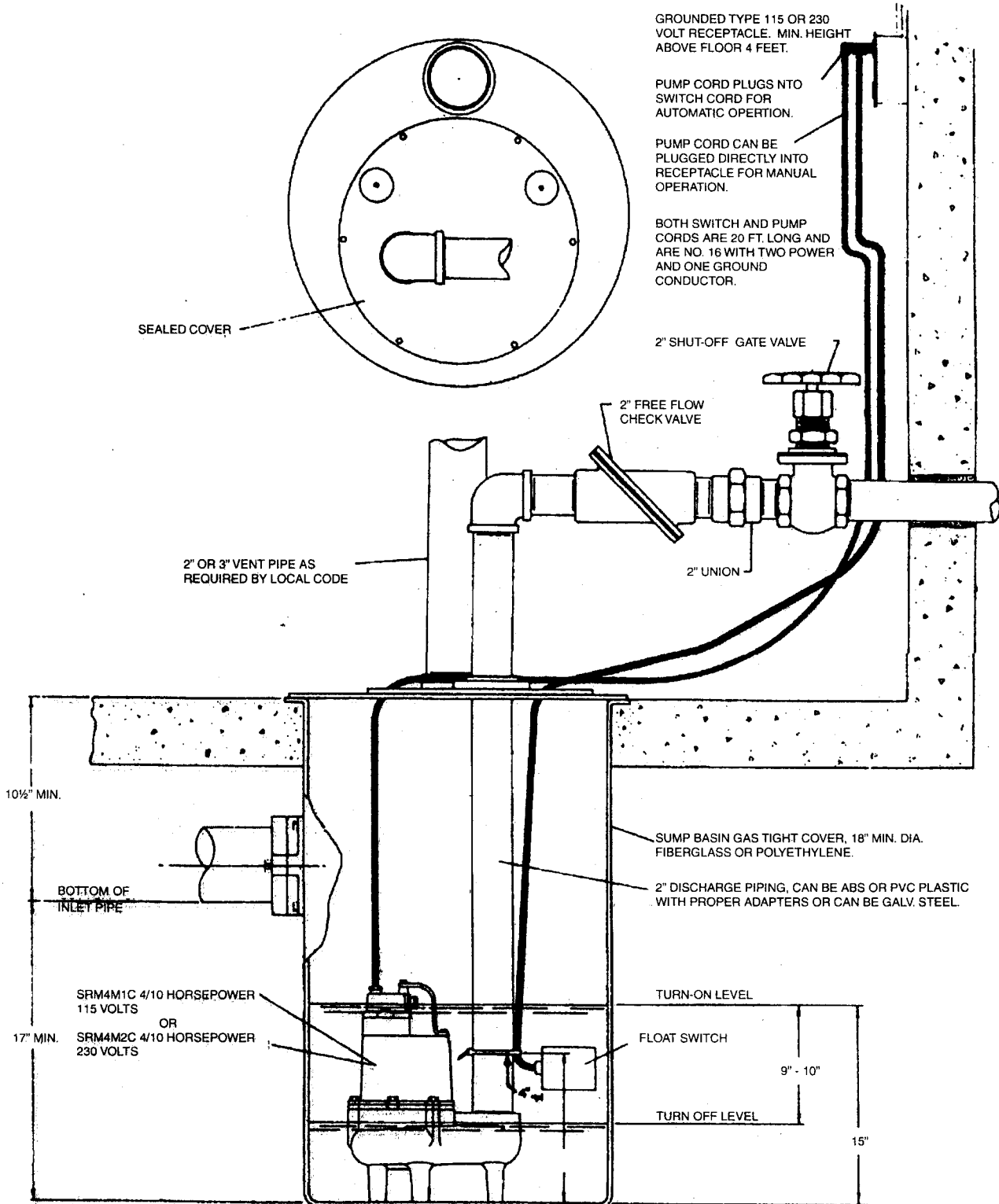

**CAUTION: FOR ANY WORK ON PUMP OR SWITCH, ALWAYS UNPLUG POWER CORD. DO NOT JUST TURN OFF CIRCUIT BREAKER OR UNSCREW FUSE.**

**TO REPLACE AUTOMATIC FLOAT**

- (1) Unplug the pump power cord from the back of the piggyback float plug.
- (2) Unplug the piggy-back float plug from the power receptacle.
- (3) Remove the pump from the sump if access to the tether point is inaccessible.
- (4) Disconnect the switch from its tether point and remove from the discharge piping.
- (5) Re-tether the new cord to the pump or discharge piping.
- (6) Cable tie or tape the power and switch cords to the discharge piping.
- (7) Plug the switch into the power receptacle.
- (8) Plug the power cord into the switch plug.
- (9) Fill basin and test switch operation.

**ALL PUMP REPAIRS SHOULD BE DONE AT AN AUTHORIZED MYERS SERVICE CENTER.**

**TO REPLACE THE AUTOMATIC VERTICAL FLOAT SWITCH**

- (1) Unplug the pump power cord from the back of the piggy-back plug.
- (2) Unplug the piggy-back plug from the power receptacle.
- (3) Remove the two mounting screws in the switch bracket that attached the switch assembly to the pump and remove from the discharge piping.
- (4) Mount new switch assembly to pump. Be sure to install plastic tie provided and re-tether to mounting screw.
- (5) Cable tie or tape the power and switch cords to the discharge piping.
- (6) Plug the piggy-back switch in the power receptacle.
- (7) Plug power cord into the piggy-back switch plug.
- (8) Fill basin and test switch operation.

**SSM33/SSM33I SHAFT SEAL REPLACEMENT**

- (1) Remove the oil fill plug located on the top of the motor housing and drain the oil in the housing. Properly dispose of the used oil. Do not reuse old oil since it may contain water from seal failure.
- (2) Lay the pump on its side. Remove the six screws holding the suction bottom onto the volute case. Remove the suction bottom.
- (3) Insert a slotted screwdriver through the center of the impeller hub into the slot in the shaft. With a rubber mallet, carefully tap the impeller in a counter rotating direction while holding the shaft with the screwdriver.
- (4) Remove the rotating portion (ceramic) of the seal with fingers. Pry on the stationary portion (carbon) with a pair of slotted screwdrivers to remove from volute casing. Discard the old seal assembly parts. **NEVER USE OLD SEAL PARTS, REBUILD PUMP WITH ONLY NEW SEAL ASSEMBLY.**
- (5) Thoroughly clean the shaft and volute casing with a clean cloth. If the drained oil showed signs of water, then the motor should be air dried for several days to remove any remaining moisture.
- (6) Carefully remove the new seal assembly from the package. Add a film of new oil to the rubber O.D. on the stationary portion (carbon), and insert into the seal cavity on the volute casing. Using a pushing tool (a piece of PVC pipe works well), push on the rubber portion of the stationary seal until it is evenly seated into the seal cavity. With a clean cloth, carefully wipe the seal face.

- (7) Remove the rotating portion (ceramic) from the package and carefully wipe with a clean cloth. Add a film of new oil onto the motor shaft. Slide the rotating portion over the shaft with the rubber surface of the seal facing away from the stationary seal face. Center the seal on the shaft.
- (8) Place the impeller onto the shaft. Screw the impeller clockwise onto the shaft using a screwdriver to hold the shaft from turning and tighten impeller. Check to see that the impeller spins freely after tightening.
- (9) Replace the suction bottom onto the volute casing and retain with the six screws. Evenly tighten screws.
- (10) Replace oil in the motor housing using only Myers submersible transformer oil. The level should be 3/4" below the top of the motor housing. Check with dip stick to assure that the pump is properly filled.
- (11) Plug pump into grounded receptacle to test operation. Pump must run quiet and free of vibration.

**SRM4 SHAFT SEAL REPLACEMENT**

- (1) Remove the oil fill plug located on the top of the motor housing and drain the oil in the housing. Properly dispose of the used oil. Do not reuse old oil since it may contain water from seal failure.
- (2) Remove the three cap screws holding the volute case onto the seal plate. Lift the motor assembly up and out of the volute case.
- (3) Lay the motor assembly on its side. Insert a slotted screwdriver into the slot in the center of the shaft. With a rubber mallet, carefully tap the impeller in a counter rotating direction while holding the shaft with the screwdriver.
- (4) Remove the rotating portion (ceramic) of the seal with fingers. Pry on the stationary portion (carbon) with a pair of slotted screwdrivers to remove from volute casing. Discard the old seal assembly parts. **NEVER USE OLD SEAL PARTS. REBUILD PUMP WITH ONLY NEW SEAL ASSEMBLY.**
- (5) Thoroughly clean the shaft and volute casing with a clean cloth. If the drained oil showed signs of water, then the motor should be air dried for several days to remove any remaining moisture.
- (6) Carefully remove the new seal assembly from the package. Add a film of new oil to the rubber O.D. on the stationary portion (carbon), and insert into the seal cavity on the volute casing. Using a pushing tool (a piece of PVC pipe works well), push on the rubber portion of the stationary seal until it is evenly seated into the seal cavity. With a clean cloth, carefully wipe the seal face.
- (7) Remove the rotating portion (ceramic) from the package and carefully wipe with a clean cloth. Add a film of new oil into the motor shaft. Slide the rotating portion over the shaft with the rubber surface of the seal facing away from the stationary seal face. Center the seal on the shaft.
- (8) Place the impeller onto the shaft. Screw the impeller clockwise onto the shaft using a screwdriver to hold the shaft from turning and tighten impeller. Check to see that the impeller spins freely after tightening.
- (9) Place the pump motor assembly upright and set it into the volute case. Replace the four cap screws and tighten.
- (10) Replace oil in the motor housing using only Myers submersible transformer oil. The level should be 3/4" below the top of the motor housing. Check with dip stick to assure that the pump is properly filled.
- (11) Plug pump into grounded receptacle to test operation. Pump must run quiet and free of vibration.

## POWER CORD REPLACEMENT

- (1) Loosen the plastic compression nut that retains the power cord. Slide nut out of the motor housing.
- (2) Pull the power cord from the motor housing. The cord may need to be wiggled back and forth several times to loosen from the housing. Pull the power cord out until the connecting wires are fully exposed. Disconnect the motor power and ground leads with a pair of pliers.
- (3) Reconnect the motor power leads and ground to the new power cord. The ground terminal on the power cord has a male connector, and the power terminals on the new power cord are female.
- (4) Carefully push the connected wires into the motor housing until the molded body of the power cord seats. Make sure that the wires stay away from the rotor and shaft. Slide the nut into place and hand tighten. Tighten the nut with 13/16" wrench until snug, but do not over tighten.
- (5) Plug pump into grounded receptacle to test operation. Pump must run quiet, free of vibration, without tripping out breaker.

## MOTOR REPLACEMENT

- (1) Disconnect the power cord and drain the oil as noted in the previous sections. If the oil shows signs of water or other contamination, it may be necessary to replace the seal assembly as noted in a previous section.
- (2) Loosen and remove the three cap screws retaining the motor housing. Lift the motor housing off of the pump assembly.
- (3) Remove the O-ring from the remaining pump assembly. Clean surface area and place new o-ring into position. Be careful not to cut o-ring when installing.
- (4) Position new motor housing (with new stator), onto the pump assembly. Align the screw bosses, and insert the three cap screws. Evenly tighten the cap screws.
- (5) Reinstall the power cord as noted in the previous section.
- (6) Replace oil in the motor housing using only Myers submersible transformer oil. The level should be 3/4" below the top of the motor housing. Check with dip stick to assure that the pump is properly filled.
- (7) Plug pump into grounded receptacle to test operation. Pump must run quiet, free of vibration, without tripping out breaker.

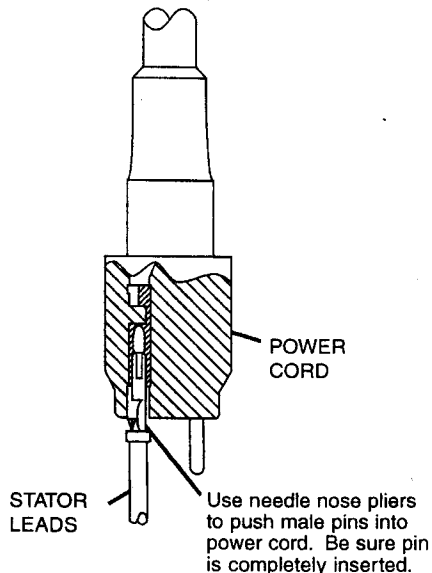

## SSM331 SERIES DIMENSIONAL DRAWINGS

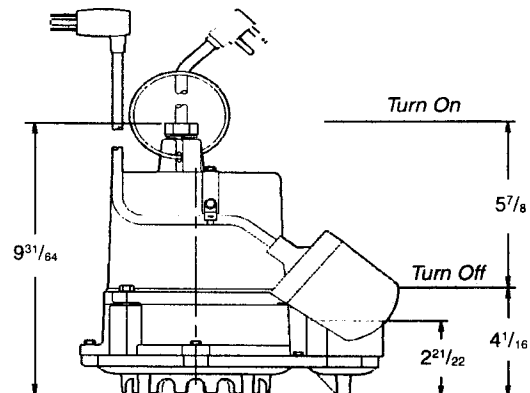
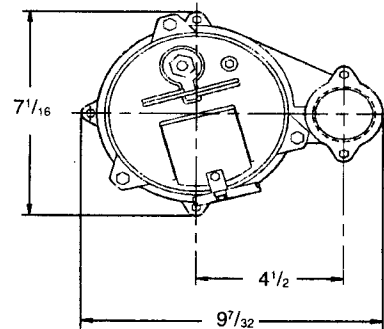
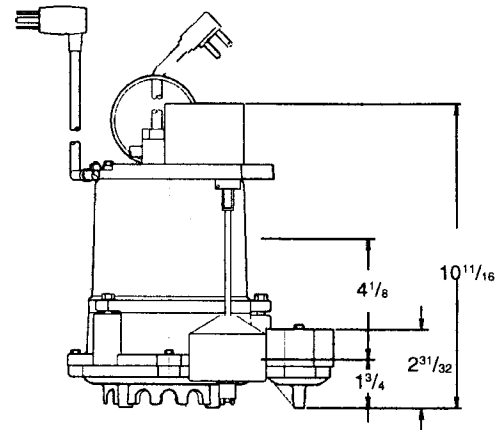
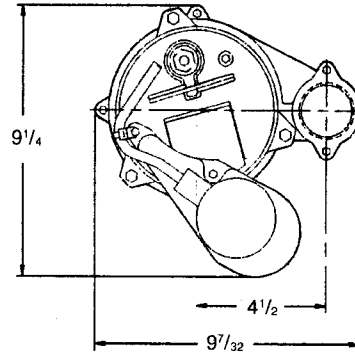

## SRM4 DIMENSIONAL DRAWING

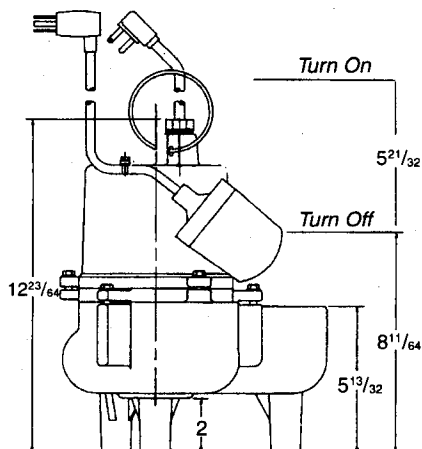
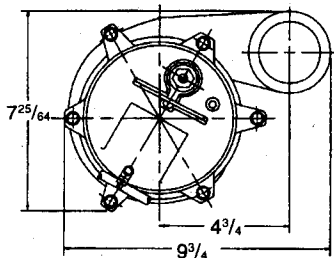

## PERFORMANCE CURVES

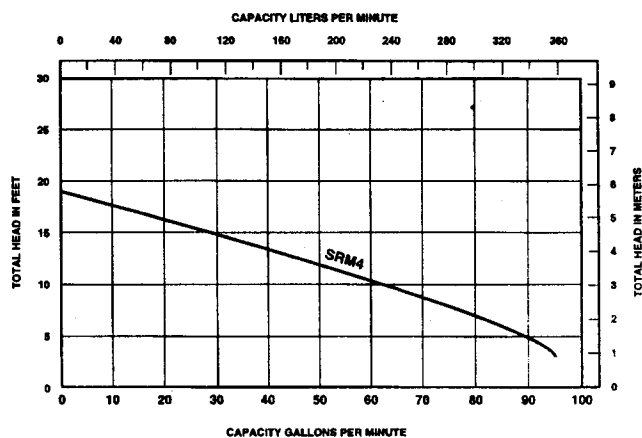
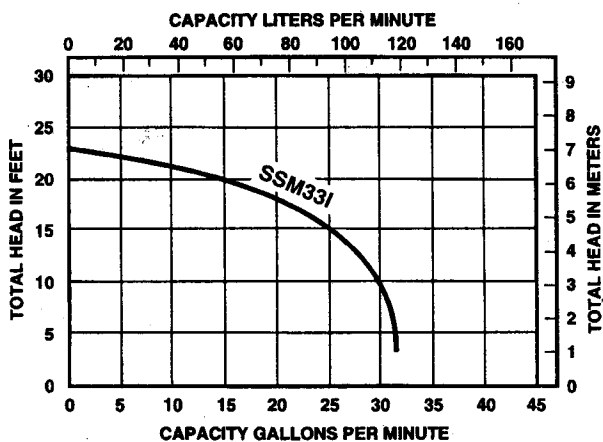

13800A991 8/01

**Myers®**  
Pentair Pump Group

F. E. Myers, 1101 Myers Parkway, Ashland, Ohio 44805-1969  
419/289-1144, FAX: 419/289-6658, [www.femyers.com](http://www.femyers.com)  
Myers (Canada), 269 Trillium Drive, Kitchener, Ontario N2G 4W5  
519/748-5470, FAX: 519/748-2553

# MYERS LIMITED WARRANTY SUMP & RESIDENTIAL SEWAGE

During the time periods and subject to the conditions hereinafter set forth, **F. E. Myers** will repair or replace to the original user or consumer any portion of your new **MYERS product which proves defective due to defective materials or workmanship of MYERS**. Contact your nearest Authorized **MYERS Dealer** for warranty service. At all times **MYERS** shall have and possess the sole right and option to determine whether to repair or replace defective equipment, parts, or components. Damage due to lightning or conditions beyond the control of **MYERS** is NOT COVERED BY THIS WARRANTY.

## WARRANTY PERIOD

**Pumps:** 12 months from date of purchase or 18 months from date of manufacture.

**Labor, etc. Costs:** **MYERS** shall IN NO EVENT be responsible or liable for the cost of field labor or other charges incurred by any customer in removing and/or reaffixing any **MYERS** product, part or component thereof.

**THIS WARRANTY WILL NOT APPLY:** (a) to defects or malfunctions resulting from failure to properly install, operate or maintain the unit in accordance with printed instructions provided; (b) to failures resulting from abuse, accident or negligence; (c) to normal maintenance services and the parts used in connection with such service; (d) to units which are not installed in accordance with applicable local codes, ordinances and good trade practices; or (e) unit is used for purposes other than for what it was designed and manufactured, and (f) if three phase submersible motors are installed on a single phase power supply using a phase converter or if three phase power is supplied by only two transformers, making an open Delta system.

**RETURN OR REPLACED COMPONENTS:** any item to be replaced under this Warranty must be returned to **MYERS** in Ashland, Ohio, or such other place as **MYERS** may designate, freight prepaid.

**PRODUCT IMPROVEMENTS:** **MYERS** reserves the right to change or improve its products or any portions thereof without being obligated to provide such a change or improvement for units sold and/or shipped prior to such a change or improvement.

**WARRANTY EXCLUSIONS:** **MYERS** SPECIFICALLY DISCLAIMS THE IMPLIED WARRANTIES OF MERCHANTABILITY AND FITNESS FOR A PARTICULAR PURPOSE AFTER THE TERMINATION OF THE WARRANTY PERIOD SET FORTH HEREIN.

Some states do not permit some or all of the above warranty limitations and, therefore, such limitations may not apply to you. No warranties or representations at any time made by any representatives of Myers shall vary or expand the provision hereof.

**LIABILITY LIMITATION:** IN NO EVENT SHALL **MYERS** BE LIABLE OR RESPONSIBLE FOR CONSEQUENTIAL, INCIDENTAL OR SPECIAL DAMAGES RESULTING FROM OR RELATED IN ANY MANNER TO ANY **MYERS** PRODUCT OR PARTS THEREOF. PERSONAL INJURY AND/OR PROPERTY DAMAGE MAY RESULT FROM IMPROPER INSTALLATION. **MYERS** DISCLAIMS ALL LIABILITY, INCLUDING LIABILITY UNDER THIS WARRANTY, FOR IMPROPER INSTALLATION -- **MYERS** RECOMMENDS FOLLOWING THE INSTRUCTIONS IN THE INSTALLATION MANUAL. WHEN IN DOUBT, CONSULT A PROFESSIONAL.

Some states do not allow the exclusion or limitation of incidental or consequential damages, so the above limitation or exclusion may not apply to you.

This Warranty gives you specific legal rights and you may also have other rights which vary from state to state.

In the absence of suitable proof of this purchase date, the effective date of this warranty will be based upon the date of manufacture.

**DETERMINATION OF UNIT DATE OF MANUFACTURE:** Submersible Sump pump (8-95) month and year stamped on pump nameplate; column sump pump month and year on red warranty tag.

**Myers**

Pentair Pump Group

F. E. Myers, 1101 Myers Parkway, Ashland, Ohio 44805-1969  
419/289-1144, FAX: 419/289-6658, www.femyers.com