

# BRONZE PEDESTAL RUBBER IMPELLER PUMP

PIPE SIZE 1"

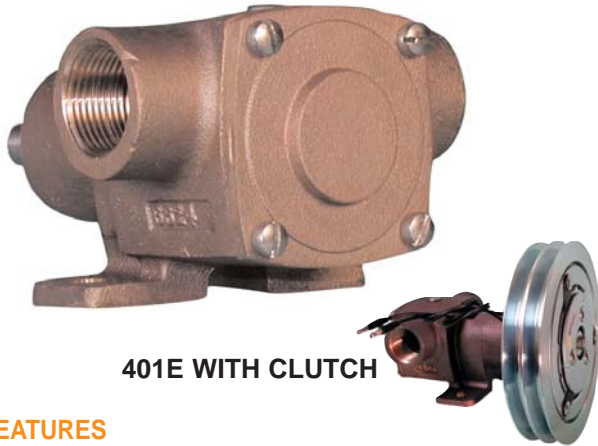

401E WITH CLUTCH

## FEATURES

- Bronze Construction - Corrosion Resistance
- Large Suction and Discharge Ports
- Teflon(R)\* Barrier Seals Protecting Ball Bearings
- Mechanical Carbon Ring, Ceramic Face Main Pump Seal Standard
- Two Sealed Ball Bearings Spaced for Maximum Load Ability
- Large Vent & Drain Openings Separate Seal & Bearing Areas
- Shaft Slinger for Additional Bearing Protection
- Neoprene Impeller Standard, Buna N Impeller Optional (Both are Spline Drive)
- High Chrome Nickel Stainless Steel Shaft
- Extra Capacity Ball Bearings plus Rugged Construction for Prolonged Service Life
- Impeller & Cam Easily Replaced
- Buna N O-ring Between Body and Cover Eliminates Gasket Problems
- Electric Clutch Options

## ROTATION

Direction of shaft rotation determines inlet and outlet ports (see line drawing)

## MOUNTING

Pump will operate satisfactorily when mounted in any position. **DO NOT RUN DRY.** Rubber impeller pumps generate high rubbing friction unless lubricated by liquid pumped. Lack of liquid will cause impeller to burn up.

## DRIVE

Either direct drive with flexible coupling or pulley drive

## PERFORMANCE

Capacity Water at 60°F

Pump Model	RPM	Feet Hd. PSI	0	20	40	60	80
			0	8.7	17.3	26.0	34.6
401M-02	800	GPM	12.0	11.0	9.70	7.5	2
		HP	1/3	1/3	1/2	1/2	3/4
401M-03	1750	GPM	25.0	24.0	22.2	19.1	15
		HP	3/4	3/4	3/4	1	1
	2500	GPM	32.5	30.5	27.0	24.0	17.5
		HP	1	1 1/2	1 1/2	2	2
	3000	GPM	36.0	34.5	31.0	27.5	21
		HP	1 1/2	1 1/2	1 1/2	2	2

can be used. Make sure both flexible coupling halves are properly aligned. When using pulley, do not overtighten belt.

## LIQUIDS AND TEMPERATURE

Liquids compatible with neoprene can be pumped including fresh and salt water solutions and mild chemicals. Do not pump severe solvents or acids. When possible, flush pump with fresh water after each usage. Buna N impellers can handle oil contaminated water and kerosene at reduced impeller service life.

Extremes of cold and heat will affect impeller life. Limits of 40° to 140° F should be observed. Do not allow liquid in pump to freeze. Drain pump by loosening cover screws. Use methyl alcohol based anti-freeze compounds such as Zerex, Shell Zone, Pyro Permanent, Permguard, Dowgard.

## SUCTION LIFT

Suction lift of 15 feet is possible when impeller is wet. Suction lines must be air tight in order for pump to self prime. A foot valve at beginning of suction line is recommended.

## IMPELLER REPLACEMENT

The impeller must be replaced if it is worn out or has been damaged by debris or by running the pump dry. Symptoms of a defective impeller are low pumping pressure and low flow causing overheating of the boat engine. Poor pump performance can also be caused by slippage of V-belts, so belts should be checked for tightness.

To replace the impeller remove screws and cover. Pull out the impeller with nose pliers or two screwdrivers. Be careful not to dent the pumping chamber with these tools. When inserting new impeller, line up key slot in impeller with the key in the shaft. Use oil on shaft and avoid forcing the impeller onto the shaft.

The impeller should also be removed for storage periods to prevent the blades from taking a permanent set.

\*Teflon(R) is a registered trademark of DuPont. Teflon(R) or equivalent PTFE will be used.

# BRONZE PEDESTAL RUBBER IMPELLER PUMP

## EXPLODED VIEW AND PARTS LIST

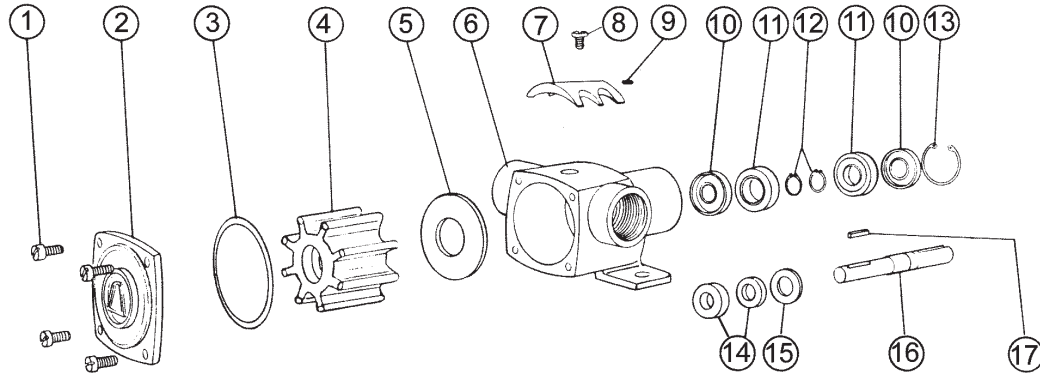

Pump No.	1	2	3 <sup>1</sup>	4 <sup>1</sup>	5	6	7	8	9	10	11	12	13	14 <sup>1</sup>	15	16	17	Repair Kit <sup>1</sup>
	Screw	Cover	O-Ring	Impeller	Wear Plate	Body	Cam	Screw	Pin	Lip Seal	Ball Bearing	Snap Ring	Snap Ring	Mech/Lip Seal	Washer	Shaft	Key Exter.	Repair Kit <sup>1</sup>
	4 Reqd	1 Reqd	1 Reqd	1 Reqd	1 Reqd	1 Reqd	1 Reqd	1 Reqd	1 Reqd	2 Reqd	1 Reqd	2 Reqd	2 Reqd	1 Reqd	1 Reqd	1 Reqd	1 Reqd	
401M-02	5504	6625	8230	7441	6635	6624	6606	7300-62	6685	6609	5928	5926	5925	32230	6631	7170	6567	10907
401M-03	5504	6625	8230	7466	6635	6624	6606	7300-62	6685	6609	5928	5926	5925	32230	6631	7170	6567	11237

<sup>1</sup> Repair Kits contain items 3, 4, & 14 and seal installation tools: 6751 pin (to occupy keyway and 6752 bushing to protect seal from sharp edges)

Pump	Impeller
401M-02	Neoprene
401M-03	Buna N

## CLUTCH OPTIONS

Pump No.	Clutch Drive Options	Clutch Body	Clutch Coil	Clutch Assy	401M Clutch Conversion Kit	Pump Repair Kit
401-E12	Rubber Impeller Pump with 12 Volt Clutch	7226	7224	32236*	10728	
401-E24	Rubber Impeller Pump with 24 Volt Clutch	7226	9902	32232	10854	10907
401-E32	Rubber Impeller Pump with 32 Volt Clutch	7226	7225	32237	10855	

\* or OGURA 9991

## DIMENSIONS

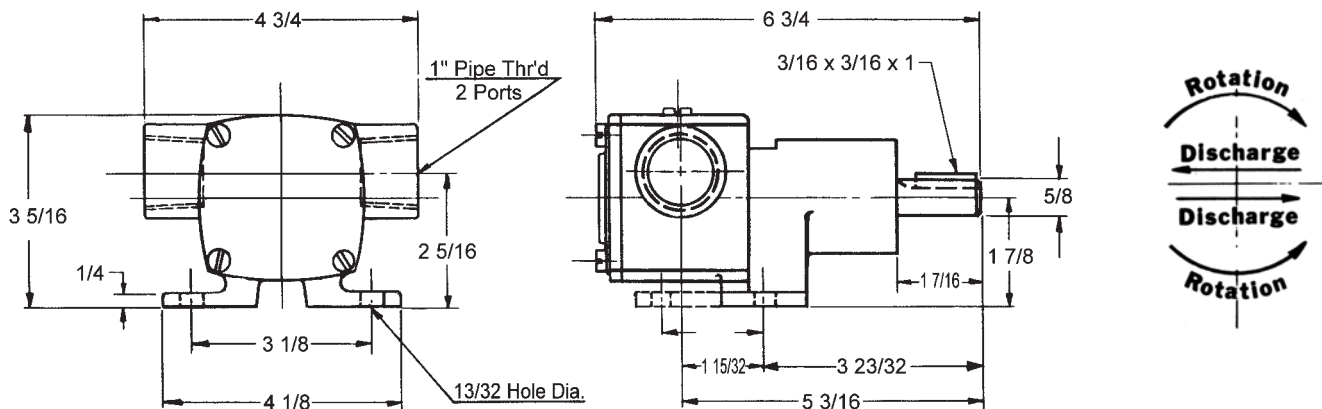

(Continued from front)

## SEAL REPLACEMENT

If water drips from the weep hole or from the area where the shaft exits the pump, the seal is defective and must be replaced. While the Teflon(R)\* barrier seal provides a first line of defense, prolonged running of the pump with a leaky seal can destroy the ball bearings resulting in catastrophic pump failure and engine shut-down.

For seal replacement, the pump must be removed from the

engine and disassembled in order to gain access to the seal area. Where mechanical seals are used, both components (stationary and rotating member) must be replaced at the same time. Lip seals must be pushed out of their press-fitted position and new seals pressed into place, using a sealant on the outside of the lip seal housing.

Refer to exploded view drawings for seal location and part numbers for ordering purposes.