

BRONZE PEDESTAL ROTARY GEAR PUMPS

MODEL N2000L - 1/4" NPT PORTS

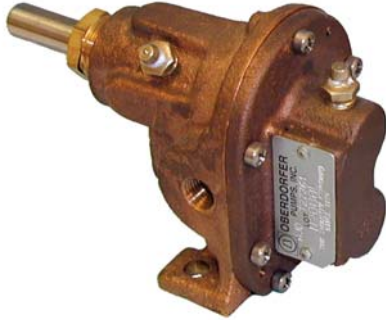

MODEL N2000LR



FEATURES

- Bronze corrosion resistant castings
- Special cast bronze helical gears for quiet operation
- Stainless steel shafts & fasteners
- Synthetic braided compression packing (with Teflon® dispersion) is standard
- Optional lip seals are available
- Positive displacement flow
- Bronze bearing surfaces with grease fittings

MOUNTING AND DRIVE ARRANGEMENT

Pumps should be mounted on a rigid base and properly aligned with the motor. Direct drive via flexible shaft coupling is the preferred method. When a belt drive is needed, additional support is necessary to absorb the added pulley load. This can be accomplished in two ways:

- 1) Use the standard pump arrangement by adding an independently supported jackshaft (see figure 2 below) or use kit 2P
- 2) When space is an issue, use an optional "long shafted" pump and add a properly shimmed pillow block bearing (see figure 1).

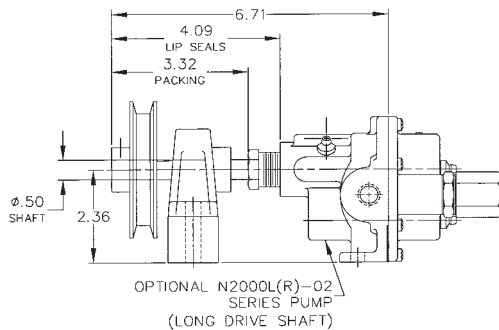

FIGURE 1

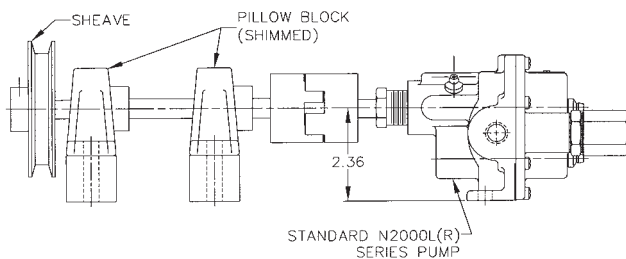

FIGURE 2

LIQUIDS AND TEMPERATURE

Service life will be increased substantially if the liquid pumped is clean and has some degree of lubricity. These positive displacement pumps have tight tolerances. Fine abrasives like sand, silt, or powders in suspension will accelerate pump wear and reduce throughput.

Liquids compatible with bronze and stainless steel can be pumped providing proper seal has been specified (see chemical compatibility or check factory). No carbon bearings used. When possible, flush the pump after each usage.

Temperature extremes are detrimental to service life and should be avoided. Basic metals of construction allow a temperature range of -40 to 400°F. Some lip seal elastomers have a limit of 212°F. (see engineering data or check factory). Allowing a liquid to freeze in the pump can cause damage.

SUCTION LIFT

Close tolerances and the positive pumping action make the rotary gear pump capable of lifting water on the suction side as high as 20 feet. Though gear pumps are self priming, a foot valve is recommended. If possible, wet the gears with liquid to be pumped for the first dry start. Liquid retained in the system and gear chambers serves to "wet" the pump on subsequent starts.

CAPACITY - WATER 70 F

R.P.M.	FT.HD.	0	46	92	138	184	231	290	346
	P.S.I.	0	20	40	60	80	100	125*	150*
400	GPM	0.97	0.69	0.40	0.10	---	---	---	---
	HP	0.02	0.04	0.08	0.10	---	---	---	---
	MOTOR	1/6	1/6	1/6	1/6	---	---	---	---
600	GPM	1.50	1.30	1.09	0.88	0.68	0.47	0.21	---
	HP	0.03	0.05	0.09	0.13	0.18	0.24	0.26	---
	MOTOR	1/6	1/6	1/6	1/6	1/4	1/4	1/4	---
800	GPM	2.03	1.82	1.62	1.41	1.21	1.00	0.65	0.30
	HP	0.04	0.07	0.11	0.15	0.22	0.29	0.36	0.45
	MOTOR	1/6	1/6	1/6	1/6	1/4	1/3	1/2	1/2
1000	GPM	2.50	2.30	2.10	1.90	1.70	1.50	1.00	0.50
	HP	0.04	0.08	0.13	0.18	0.24	0.32	0.45	0.55
	MOTOR	1/6	1/6	1/6	1/4	1/4	1/3	1/2	1/2
1200	GPM	2.92	2.72	2.52	2.31	2.10	1.90	1.50	1.00
	HP	0.05	0.09	0.16	0.22	0.28	0.36	0.48	0.58
	MOTOR	1/6	1/6	1/6	1/4	1/3	1/3	1/2	1/2
1600	GPM	3.75	3.55	3.35	3.15	2.95	2.75	2.45	2.20
	HP	0.06	0.11	0.18	0.25	0.33	0.41	0.53	0.65
	MOTOR	1/6	1/6	1/4	1/4	1/3	1/2	1/2	3/4
1725	GPM	4.07	3.86	3.65	3.44	3.23	3.03	2.80	2.50
	HP	0.10	0.14	0.20	0.29	0.37	0.43	0.56	0.68
	MOTOR	1/6	1/6	1/4	1/3	1/2	1/2	3/4	3/4

H.P. = Actual Horsepower

Motor = Convenient Fractional Size

G.P.M. = Gallons per Minute

P.S.I. = Lbs. Per Square Inch Pressure

R.P.M. = Revolutions per Min.

Ft. Hd. = Equiv. Press. in Ft of Water

*For pressures over 100 psi, the above selections are suitable for pumping fluids with lubricity (e.g. oils, polymers). Service life will decrease for fluids without lubricity (e.g. water, solvents).

MODELS

N2000L
N2000LR
SERIES

BRONZE PEDESTAL ROTARY GEAR PUMPS

EXPLODED VIEW AND PARTS LIST

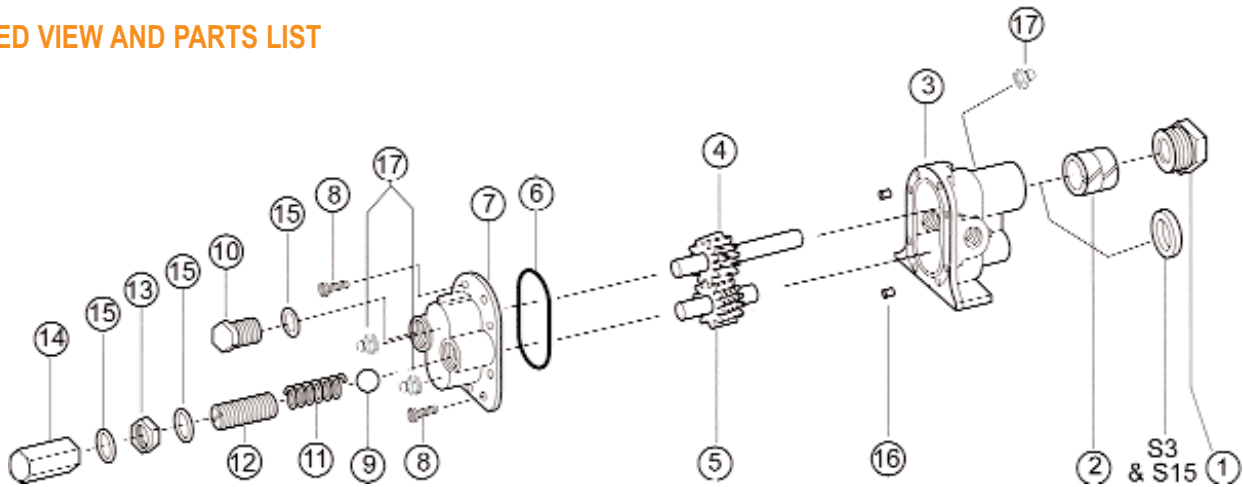

Pump No	Seal Arrangement	1	2a	2b	3	4	5	6	7	8	9	10	11	12	13	14	15	16	17	Repair Kit
		Packnut	Packing	Seal	Body	Drive Gear Ass'y	Idle Gear Ass'y	O-ring	Cover	Screw	Ball	Plug Nut	Spring	Adj. Screw	Locknut	Bypass Nut	Fiber Washer	Dowel Pin	Grease Fitting	
		1 req'd	2 req'd	1 req'd	1 req'd	1 req'd	1 req'd	1 req'd	1 req'd	7 req'd	1 req'd	1 req'd	1 req'd	1 req'd	1 req'd	1 req'd	3 req'd	2 req'd		
N2000L	Packing	1892	5481	NA	9315PB1N-1	32992	32993	9797-038	9316PN5N-1	5385								8885	5390	12291
N2000LS3	Buna Lip	NA		5007	9315PB2N-1	32978	32993	9797-033	9316PN5N-1	5385								8885	5390	11379
Relief Valve Versions: N2000LR, N2000LRS3, (incremental parts)									9317PN5B-1		5238	1838	1840	5237	5240	5239	6533			

All Repair Kits contain items 2,4,5,6

BY-PASS AND ROTATION

The pump by-pass is not intended to be a metering or flow control device. Its main purpose is to function as a pressure relief when the desired set point is exceeded, overheating can occur within 5 -10 minutes if the discharge line is completely shut off for extended periods.

Reversing rotation reverses the "IN" and "OUT" ports and the location of the by-pass ports have to be reversed.

The by-pass valve is factory set at 50 p.s.i. To increase the setpoint, turn the by-pass valve adjusting screw in a clockwise direction.

DIMENSIONS

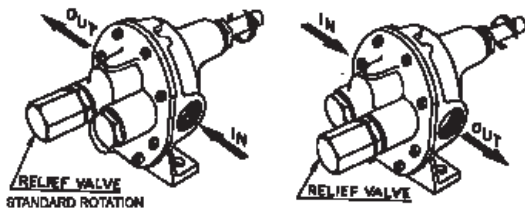
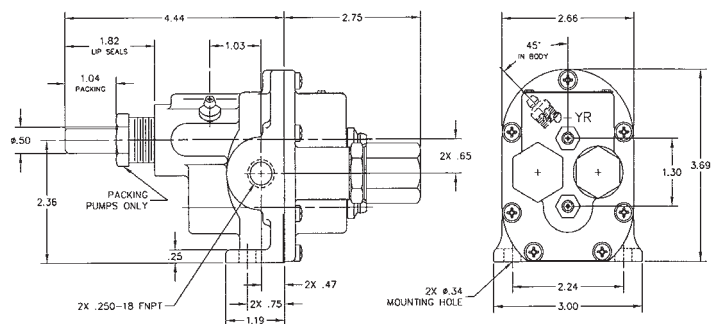

DIMENSIONS N2000L & N2000LS3

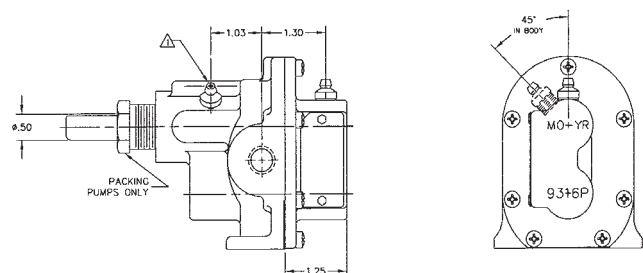

* Viton® or equivalent FKM will be used. Viton® is a registered trademark of DuPont Dow Elastomers.
Teflon® or equivalent PTFE will be used. Teflon® is a registered trademark of DuPont.

⚠ GREASE FITTINGS (ITEM 17) INSTALLED INTO .125-27 NPT CONNECTIONS.