

Please read and save this Repair Parts Manual. Read this manual and the General Operating Instructions carefully before attempting to assemble, install, operate or maintain the product described. Protect yourself and others by observing all safety information. The Safety Instructions are contained in the General Operating Instructions. Failure to comply with the safety instructions accompanying this product could result in personal injury and/or property damage! Retain instructions for future reference.

SHERTECH[®] Close-Coupled Centrifugal Pumps

316 Stainless Steel, Bronze and Cast Iron Models

Refer to form L-4077 for General Operating and Safety Instructions and Applicable Warranty.

Description

Shertech close-coupled cast iron, bronze or 316 stainless steel units pump continuously, producing high flow rates under low-head conditions. Designed for continuous low-pressure circulation and transfer of non-flammable liquids, utility, boiler feed, general transfer, filtration, cooling towers, condensate return, marine applications, fountains, boosters, water circulation, irrigation, spraying systems, jockey pump service, chemical processing, aggressive liquid applications and other general-purpose pumping compatible with pump component materials where no suction lift or no self-priming is required.

- Capacities to 170 GPM, heads to 74 ft.
- 1/3 to 3 HP AC, NEMA 56J frame & base, ODP & TEFC, single & three-phase motors. Single-phase motors are equipped with thermal overload protection. Overload protection not supplied on three-phase units and must be provided in starter units. Pump control box must be ordered separately.
- Clog-resistant, semi-open metallic impellers.
- Pumps feature maintenance-free ball bearings and an easily accessible front drain plug for draining liquid.
- Maximum casing working pressure is 200 PSI.
- Standard pump models (at 3450 RPM) will handle specific gravities to 1.1 (at 100 SSU or less). For specific gravities to 1.4 (at 100 SSU or less), increase motor HP by one size but not to exceed standard 3 HP motor at 3450 RPM or 65 in.-lbs. of torque maximum. Higher specific gravity fluids are not recommended.
- Standard pump models (at 3450 RPM) will handle viscosity to 100 SSU (at 1.1 specific gravity or less) and up to 200 SSU (specific gravity of 1.0 or less). For viscosity up to 400 SSU (specific gravity of 1.0 or less), increase motor HP by one size but not to exceed standard 3 HP motor at 3450 RPM or 65 in.-lbs. of torque. For fluids with a viscosity greater than 400 SSU, pump speed must be reduced below 3450 RPM.
- 3/4" to 2" female NPT inlet and outlet ports.
- Discharge port can be rotated at 90-degree intervals.
- Cast Iron and Bronze units handle temperatures to 200° F; Stainless Steel units handle temperatures to 250° F.
- Seals: Pumps are equipped with a carbon ceramic mechanical seal having 316 stainless steel components. These seals protect the motor shaft, which is 300 series stainless steel, from chemical exposure. Buna-N seal & o-ring in cast iron and bronze models, with Viton seal & o-ring in 316 stainless steel models. Aftermarket options listed below.

REPAIR SEALS AND OPTIONS – Standard (Viton & Buna-N) and an upgraded (Silicon Carbide) seal are available. If abrasive or small, particulated fluids are being pumped, upgrade to the silicon carbide mechanical seal with Viton elastomers is recommended. Standard and upgraded seals can be located in the repair parts list pages in this manual.

PEDESTAL MODELS – Shertech Pedestals are available and can be long coupled or pulley driven.

CLOSE-COUPLED PUMP HEADS AND PEDESTAL MOUNT BASE – Complete pump heads can be ordered from Shertech Parts. Pump head model numbers and optional pedestal base are called out in the repair parts list pages in this manual.



Do not use to pump flammable or explosive fluids such as gasoline, fuel oil, kerosene, etc. Do not use in flammable and/or explosive atmospheres. When pumping hazardous or dangerous materials, use only in room or area designated for that purpose. For your protection, always wear proper clothing, eye protection, etc. in case of any malfunction. For proper handling techniques and cautions, contact your chemical supplier, insurance company and local agencies (fire dept., etc.). Failure to comply with this warning could result in personal injury and/or property damage.

SHERTECH® Close-Coupled Centrifugal Pumps

316 Stainless Steel, Bronze and Cast Iron Models

Model Ordering Codes and Options

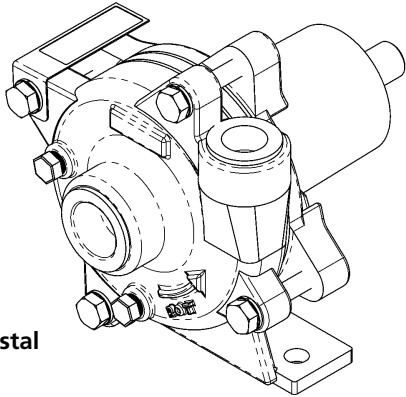

P: Pedestal

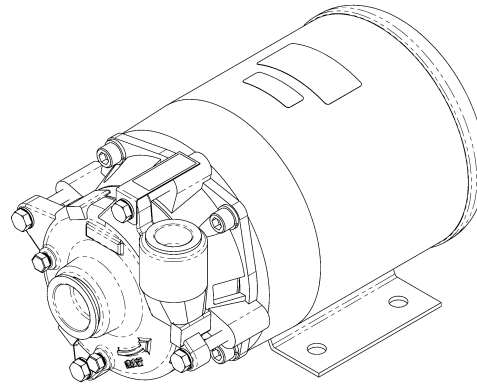

M: Motor (with base)

Example Model: COMSV44 (1 HP ODP motor with >1.15 Service Factor*)

or

COMSV45T (1.5 HP TEFC motor with 1.0 Service Factor*)

(1) CO (2) M (3) S (4) V (5) 4 (6) 5 (7) T

1st	2nd	3rd	4th	5th	6th	7th
Series	Mounting	Material	Seal** (Mech)	Impeller Sz. (NPT Ports)	Motor-Mounted Only HP	AC Type
CO: Centrifugal Semi-Open Impeller	M: Motor (with Base) P: Pedestal	S: 316 SS Body and Impeller B: Bronze Body and Impeller C: Cast Iron Body and Impeller	B: Buna-N (Stainless Steel Case) C: Viton (Stainless Steel Case) (Silicon Carbide Seal and Seat Faces) V: Viton (Stainless Steel Case)	1 (3/4" - 1") 2 (1" - 1 1/4") 3 (1" - 1 1/4") 4 (1 1/4" - 1 1/2") 5 (1 1/4" - 1 1/2") 6 (1 1/4" - 1 1/2") 7 (1 1/2" - 2") <i>To identify your impeller size see chart on page 12.</i>	1: 1/3 2: 1/2 3: 3/4 4: 1 5: 1 1/2 6: 2 7: 3 X: 56J Frame Motor "wet-end kit" Example: COMSV1X	Blank: no code single phase ODP motor 3: 3 phase ODP motor T: 1 phase TEFC 3T: 3 phase TEFC

NOTE: Not all order code combinations (configurations) are standard models available from the manufacturer. Custom model configurations may require ordering standard components and/or optional parts that will need to be assembled by the customer.

Manufacturer reserves the right to change model order codes, standard models, specifications, and performance without notification.

(*) ODP motors have > 1.15 service factors. Due to service factor, it is recommended TEFC motors are oversized by one HP increment.

Pedestal Pumps are not supplied with a motor.

(**) Unless otherwise noted, seal faces are carbon on ceramic.

316 Stainless Steel, Bronze and Cast Iron Models

Performance – Standard Models (Water at 70°)

Impeller Size	316 Stainless Steel Models	Bronze Models	Cast Iron Models	HP**	GPM of Water at Total Head in Feet*									Max. Head
					10	15	20	30	40	50	60	70	80	
1	COMSV1X	COMBB1X	COMCB1X	1/3	41	37	34	25	10	-	-	-	-	44
2	COMSV2X	COMBB2X	COMCB2X	1/2	55	50	45	33	10	-	-	-	-	42
3	COMSV3X	COMBB3X	COMCB3X	3/4	72	68	63	53	41	22	-	-	-	55
4	COMSV4X	COMBB4X	COMCB4X	1	108	104	98	86	71	47	-	-	-	58
5	COMSV5X	COMBB5X	COMCB5X	1½	115	110	104	94	81	64	40	-	-	67
6	COMSV6X	COMBB6X	COMCB6X	2	124	117	110	95	80	74	60	34	-	80
7	COMSV7X	COMBB7X	COMCB7X	3	168	164	155	148	137	124	110	80	40	83

(* Test data is taken water at 70°F for pumps with 60 Hz motors at 3450 RPM motors (to convert data to PSI, divide feet of head by 2.31).

Pump performance when pump is new. As pump wears, the performance will decrease.

(**) AC HP required at specified RPM is HP rated to handle up to 100 SSU at full flow, with a maximum specific gravity of 1.1, or up to 200 SSU at 1.0 specific gravity or less.

NOTES: Max. Viscosity = For viscosity up to 400 SSU (at 1.0 specific gravity or less), increase motor HP by one size but not to exceed standard 3 HP motor at 3450 RPM or 65 in.-lbs. of torque. For fluids with a viscosity greater than 400 SSU, pump speed must be reduced below 3450 RPM.

Max. Casing PSI = 200 Max. RPM = 3450

Max. Specific Gravity = up to 1.1 for standard models (at 100 SSU or less); HP must be increased by one size for specific gravities up to 1.4.

Driver data is subject to change without notice; see label on driver for actual specifications.

Manufacturer reserves the right to change performance without notification.

Specifications (Pump heads only)

SUGGESTED DRIVER (Motor Not Included)				PUMP CONSTRUCTION (Wet End)						Ship Wt. (lbs.)
Model Number	HP	NEMA Frame	RPM	Port Size FNPT	Shaft	Body	Impeller	Motor Adapter	Seals*	
316 SS Models										
COMSV1X	1/3	56J	3450	1" x 3/4"	303 SS	316 SS	316 SS	316 SS	Viton	10
COMSV2X	1/2	56J	3450	1¼" x 1"	303 SS	316 SS	316 SS	316 SS	Viton	12
COMSV3X	3/4	56J	3450	1¼" x 1"	303 SS	316 SS	316 SS	316 SS	Viton	12
COMSV4X	1	56J	3450	1½" x 1¼"	303 SS	316 SS	316 SS	316 SS	Viton	16
COMSV5X	1½	56J	3450	1½" x 1¼"	303 SS	316 SS	316 SS	316 SS	Viton	16
COMSV6X	2	56J	3450	1½" x 1¼"	303 SS	316 SS	316 SS	316 SS	Viton	19
COMSV7X	3	56J	3450	2" x 1½"	303 SS	316 SS	316 SS	316 SS	Viton	24
Bronze Models										
COMBB1X	1/3	56J	3450	1" x 3/4"	303 SS	BR	BR	BR	Buna-N	11
COMBB2X	1/2	56J	3450	1¼" x 1"	303 SS	BR	BR	BR	Buna-N	13
COMBB3X	3/4	56J	3450	1¼" x 1"	303 SS	BR	BR	BR	Buna-N	13
COMBB4X	1	56J	3450	1½" x 1¼"	303 SS	BR	BR	BR	Buna-N	17
COMBB5X	1½	56J	3450	1½" x 1¼"	303 SS	BR	BR	BR	Buna-N	17
COMBB6X	2	56J	3450	1½" x 1¼"	303 SS	BR	BR	BR	Buna-N	20
COMBB7X	3	56J	3450	2" x 1½"	303 SS	BR	BR	BR	Buna-N	25
Cast Iron Models										
COMCB1X	1/3	56J	3450	1" x 3/4"	303 SS	CI	CI	CI	Buna-N	10
COMCB2X	1/2	56J	3450	1¼" x 1"	303 SS	CI	CI	CI	Buna-N	12
COMCB3X	3/4	56J	3450	1¼" x 1"	303 SS	CI	CI	CI	Buna-N	12
COMCB4X	1	56J	3450	1½" x 1¼"	303 SS	CI	CI	CI	Buna-N	16
COMCB5X	1½	56J	3450	1½" x 1¼"	303 SS	CI	CI	CI	Buna-N	16
COMCB6X	2	56J	3450	1½" x 1¼"	303 SS	CI	CI	CI	Buna-N	18
COMCB7X	3	56J	3450	2" x 1½"	303 SS	CI	CI	CI	Buna-N	23

SS = Stainless Steel BR = Bronze CI = Cast Iron

(*) Viton shaft seals also contains 316 stainless steel, ceramic, and carbon components. Buna-N shaft seals also contains 18-8 stainless steel, ceramic, and carbon components.

NOTE: Manufacturer reserves the right to change specifications without notification.

SHERTECH® Close-Coupled Centrifugal Pumps

316 Stainless Steel, Bronze and Cast Iron Models

Specifications for Standard Pump and Motor Models

Model Number	HP	AC Motor Type	NEMA Frame	Motor Voltage	DRIVER					PUMP CONSTRUCTION (Wet End)						Ship Wt. (lbs.)	
					Full Load Amps	Service Factor Amps	Phase	Hertz	Overload Protection	RPM	Port Size FNPT	Shaft	Body	Impeller	Motor Adapter		Seals*
316 SS Models																	
COMSV11	1/3	ODP	56J	115	5.6	7.6	1	60	Yes	3450	1" x 3/4"	303 SS	316SS	316SS	316SS	Viton	27
COMSV22	1/2	ODP	56J	115/230	7.4/3.7	9.8/4.9	1	60	Yes	3450	1 1/2" x 1"	303 SS	316SS	316SS	316SS	Viton	30
COMSV223	1/2	ODP	56J	230/460	2.2/1.1	2.8/1.4	3	50/60	No	3450	1 1/2" x 1"	303 SS	316SS	316SS	316SS	Viton	30
COMSV33	3/4	ODP	56J	115/230	9.8/4.9	13.2/6.6	1	60	Yes	3450	1 1/2" x 1"	303 SS	316SS	316SS	316SS	Viton	33
COMSV333	3/4	ODP	56J	230/460	3.2/1.6	3.6/1.75	3	50/60	No	3450	1 1/2" x 1"	303 SS	316SS	316SS	316SS	Viton	32
COMSV44	1	ODP	56J	115/230	12.0/6.0	15.4/7.7	1	60	Yes	3450	1 1/2" x 1 1/4"	303 SS	316SS	316SS	316SS	Viton	40
COMSV443	1	ODP	56J	230/460	3.7/1.85	4.4/2.2	3	50/60	No	3450	1 1/2" x 1 1/4"	303 SS	316SS	316SS	316SS	Viton	40
COMSV55	1 1/2	ODP	56J	115/230	13.4/7.4	17.6/8.8	1	60	Yes	3450	1 1/2" x 1 1/4"	303 SS	316SS	316SS	316SS	Viton	44
COMSV553	1 1/2	ODP	56J	230/460	4.9/2.5	5.9/2.9	3	50/60	No	3450	1 1/2" x 1 1/4"	303 SS	316SS	316SS	316SS	Viton	42
COMSV66	2	ODP	56J	115/230	18.2/9.1	21.6/10.8	1	60	Yes	3450	1 1/2" x 1 1/4"	303 SS	316SS	316SS	316SS	Viton	56
COMSV66T	2	TEFC	56J	115/230	9.8	10.0	1	60	Yes	3450	1 1/2" x 1 1/4"	303 SS	316SS	316SS	316SS	Viton	65
COMSV663	2	ODP	56J	230/460	6.2/3.1	7.2/3.6	3	50/60	No	3450	1 1/2" x 1 1/4"	303 SS	316SS	316SS	316SS	Viton	56
COMSV663T	2	TEFC	56J	230/460	6.0/3.0	6.4/3.2	3	50/60	No	3450	1 1/2" x 1 1/4"	303 SS	316SS	316SS	316SS	Viton	65
COMSV77	3	ODP	56J	230	12.7	14.6	1	60	Yes	3450	2" x 1 1/2"	303 SS	316SS	316SS	316SS	Viton	70
COMSV77T	3	TEFC	56J	230	13	14.6	1	60	Yes	3450	2" x 1 1/2"	303 SS	316SS	316SS	316SS	Viton	75
COMSV773	3	ODP	56J	230/460	8.9/4.2	8.4/4.2	3	50/60	No	3450	2" x 1 1/2"	303 SS	316SS	316SS	316SS	Viton	70
COMSV773T	3	TEFC	56J	230/460	8.4/3.8	9.2/4.2	3	50/60	No	3450	2" x 1 1/2"	303 SS	316SS	316SS	316SS	Viton	75
Bronze Models																	
COMBB11	1/3	ODP	56J	115	5.6	7.6	1	60	Yes	3450	1" X 3/4"	303 SS	BR	BR	BR	Buna-N	27
COMBB22	1/2	ODP	56J	115/230	7.4/3.7	9.8/4.9	1	60	Yes	3450	1 1/2" x 1"	303 SS	BR	BR	BR	Buna-N	30
COMBB223	1/2	ODP	56J	230/460	2.2/1.1	2.8/1.4	3	50/60	No	3450	1 1/2" x 1"	303 SS	BR	BR	BR	Buna-N	30
COMBB33	3/4	ODP	56J	115/230	9.8/4.9	13.2/6.6	1	60	Yes	3450	1 1/2" x 1"	303 SS	BR	BR	BR	Buna-N	33
COMBB333	3/4	ODP	56J	230/460	3.2/1.6	3.6/1.75	3	50/60	No	3450	1 1/2" x 1"	303 SS	BR	BR	BR	Buna-N	32
COMBB44	1	ODP	56J	115/230	12.0/6.0	15.4/7.7	1	60	Yes	3450	1 1/2" x 1 1/4"	303 SS	BR	BR	BR	Buna-N	40
COMBB443	1	ODP	56J	230/460	3.7/1.85	4.4/2.2	3	50/60	No	3450	1 1/2" x 1 1/4"	303 SS	BR	BR	BR	Buna-N	40
COMBB55	1 1/2	ODP	56J	115/230	13.4/7.4	17.6/8.8	1	60	Yes	3450	1 1/2" x 1 1/4"	303 SS	BR	BR	BR	Buna-N	44
COMBB553	1 1/2	ODP	56J	230/460	4.9/2.5	5.9/2.9	3	50/60	No	3450	1 1/2" x 1 1/4"	303 SS	BR	BR	BR	Buna-N	42
COMBB66	2	ODP	56J	115/230	18.2/9.1	21.6/10.8	1	60	Yes	3450	1 1/2" x 1 1/4"	303 SS	BR	BR	BR	Buna-N	56
COMBB66T	2	TEFC	56J	230	9.8	10.0	1	60	Yes	3450	1 1/2" x 1 1/4"	303 SS	BR	BR	BR	Buna-N	65
COMBB663	2	ODP	56J	230/460	6.2/3.1	7.2/3.6	3	50/60	No	3450	1 1/2" x 1 1/4"	303 SS	BR	BR	BR	Buna-N	56
COMBB663T	2	TEFC	56J	230/460	6.0/3.0	6.4/3.2	3	50/60	No	3450	1 1/2" x 1 1/4"	303 SS	BR	BR	BR	Buna-N	65
COMBB77	3	ODP	56J	230	12.7	14.6	1	60	Yes	3450	2" x 1 1/2"	303 SS	BR	BR	BR	Buna-N	70
COMBB77T	3	TEFC	56J	230	13	14.6	1	60	Yes	3450	2" x 1 1/2"	303 SS	BR	BR	BR	Buna-N	75
COMBB773	3	ODP	56J	230/460	8.9/4.2	8.4/4.2	3	50/60	No	3450	2" x 1 1/2"	303 SS	BR	BR	BR	Buna-N	70
COMBB773T	3	TEFC	56J	230/460	8.4/3.8	9.2/4.2	3	50/60	No	3450	2" x 1 1/2"	303 SS	BR	BR	BR	Buna-N	75
Cast Iron Models																	
COMCB11	1/3	ODP	56J	115	5.6	7.6	1	60	Yes	3450	1" X 3/4"	303 SS	CI	CI	CI	Buna-N	27
COMCB22	1/2	ODP	56J	115/230	7.4/3.7	9.8/4.9	1	60	Yes	3450	1 1/2" x 1"	303 SS	CI	CI	CI	Buna-N	30
COMCB223	1/2	ODP	56J	230/460	2.2/1.1	2.8/1.4	3	50/60	No	3450	1 1/2" x 1"	303 SS	CI	CI	CI	Buna-N	30
COMCB33	3/4	ODP	56J	115/230	9.8/4.9	13.2/6.6	1	60	Yes	3450	1 1/2" x 1"	303 SS	CI	CI	CI	Buna-N	33
COMCB333	3/4	ODP	56J	230/460	3.2/1.6	3.6/1.75	3	50/60	No	3450	1 1/2" x 1"	303 SS	CI	CI	CI	Buna-N	32
COMCB44	1	ODP	56J	115/230	12.0/6.0	15.4/7.7	1	60	Yes	3450	1 1/2" x 1 1/4"	303 SS	CI	CI	CI	Buna-N	40
COMCB443	1	ODP	56J	230/460	3.7/1.85	4.4/2.2	3	50/60	No	3450	1 1/2" x 1 1/4"	303 SS	CI	CI	CI	Buna-N	40
COMCB55	1 1/2	ODP	56J	115/230	13.4/7.4	17.6/8.8	1	60	Yes	3450	1 1/2" x 1 1/4"	303 SS	CI	CI	CI	Buna-N	44
COMCB553	1 1/2	ODP	56J	230/460	4.9/2.5	5.9/2.9	3	50/60	No	3450	1 1/2" x 1 1/4"	303 SS	CI	CI	CI	Buna-N	42
COMCB66	2	ODP	56J	115/230	18.2/9.1	21.6/10.8	1	60	Yes	3450	1 1/2" x 1 1/4"	303 SS	CI	CI	CI	Buna-N	56
COMCB66T	2	TEFC	56J	115/230	9.8	10.0	1	60	Yes	3450	1 1/2" x 1 1/4"	303 SS	CI	CI	CI	Buna-N	65
COMCB663	2	ODP	56J	230/460	6.2/3.1	7.2/3.6	3	50/60	No	3450	1 1/2" x 1 1/4"	303 SS	CI	CI	CI	Buna-N	56
COMCB663T	2	TEFC	56J	230/460	6.0/3.0	6.4/3.2	3	50/60	No	3450	1 1/2" x 1 1/4"	303 SS	CI	CI	CI	Buna-N	65
COMCB77	3	ODP	56J	230	12.7	14.6	1	60	Yes	3450	2" x 1 1/2"	303 SS	CI	CI	CI	Buna-N	70
COMCB77T	3	TEFC	56J	230	13	14.6	1	60	Yes	3450	2" x 1 1/2"	303 SS	CI	CI	CI	Buna-N	75
COMCB773	3	ODP	56J	230/460	8.9/4.2	8.4/4.2	3	50/60	No	3450	2" x 1 1/2"	303 SS	CI	CI	CI	Buna-N	70
COMCB773T	3	TEFC	56J	230/460	8.4/3.8	9.2/4.2	3	50/60	No	3450	2" x 1 1/2"	303 SS	CI	CI	CI	Buna-N	75

SS = Stainless Steel BR = Bronze CI = Cast Iron ODP = Open Drip-Proof TEFC = Totally-Enclosed Fan-Cooled

(*) Shaft Seal also contains 316 stainless steel, ceramic, and carbon components.

NOTES: Driver data is subject to change without notice, see label on driver for actual specifications.

Manufacturer reserves the right to change performance without notification.

316 Stainless Steel, Bronze and Cast Iron Models

Dimensions (Inches)

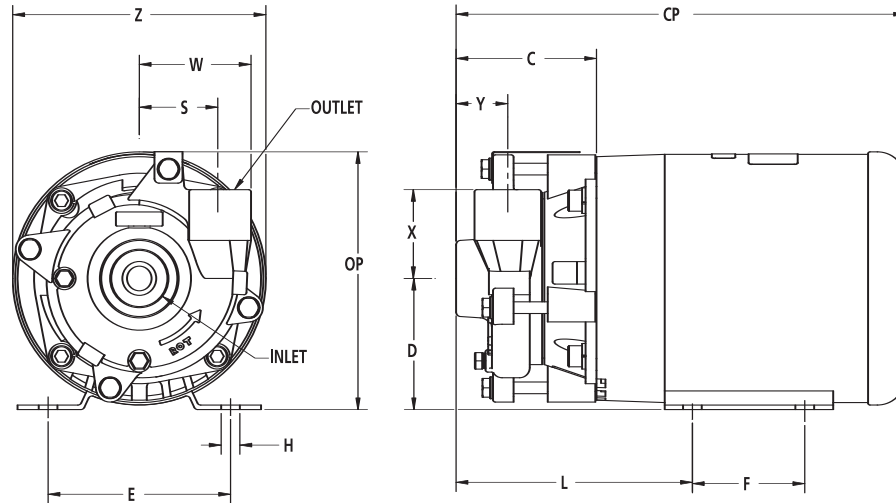

Figure 1 - Dimensions

Model	Inlet-NPT	Outlet-NPT	C	CP†	D	E	F	H	L	OP	S	W	X	Y	Z
COMSV1															
COMBB1	1"	3/4"	3.75	12	3.5	4.88	3	0.34	6.31	6.56	1.88	2.63	1.88	1.44	5.63
COMCB1															
COMSV2															
COMBB2	1-1/4"	1"	3.75	12.38	3.5	4.88	3	0.34	6.31	6.88	2.09	3	2.38	1.38	5.63
COMCB2															
COMSV3															
COMBB3	1-1/4"	1"	3.75	12.88	3.5	4.88	3	0.34	6.31	6.88	2.09	3	2.38	1.38	5.63
COMCB3															
COMSV4															
COMBB4	1-1/2"	1-1/4"	3.75	13.75	3.5	4.88	3	0.34	6.31	6.88	2.03	3.18	2.5	1.41	5.63
COMCB4															
COMSV5															
COMBB5	1-1/2"	1-1/4"	3.75	15	3.5	4.88	3	0.34	6.31	6.88	2.03	3.18	2.5	1.41	5.63
COMCB5															
COMSV6															
COMBB6	1-1/2"	1-1/4"	4.56	14.19	3.5	4.88	3	0.34	7.13	7	2.88	3.84	3.5	1.56	5.63
COMCB6															
COMSV7															
COMBB7	2"	1-1/2"	4.78	15.75	3.5	4.88	3	0.34	7.34	7	2.88	4.25	3.5	1.59	6.88
COMCB7															

All dimensions have a tolerance of 0.13".

(†) This dimension may vary due to motor manufacturer's specifications.

NOTE: Motor driver is subject to change without notice.

Contact a Shertech Distributor

Distributors can be found at www.shertech.com or www.hyproindustrial.com

(The factory only sells pumps and parts to distributors.)

Please provide following information:

- Model number
- Serial number (if any)
- Part description and number as shown in parts list

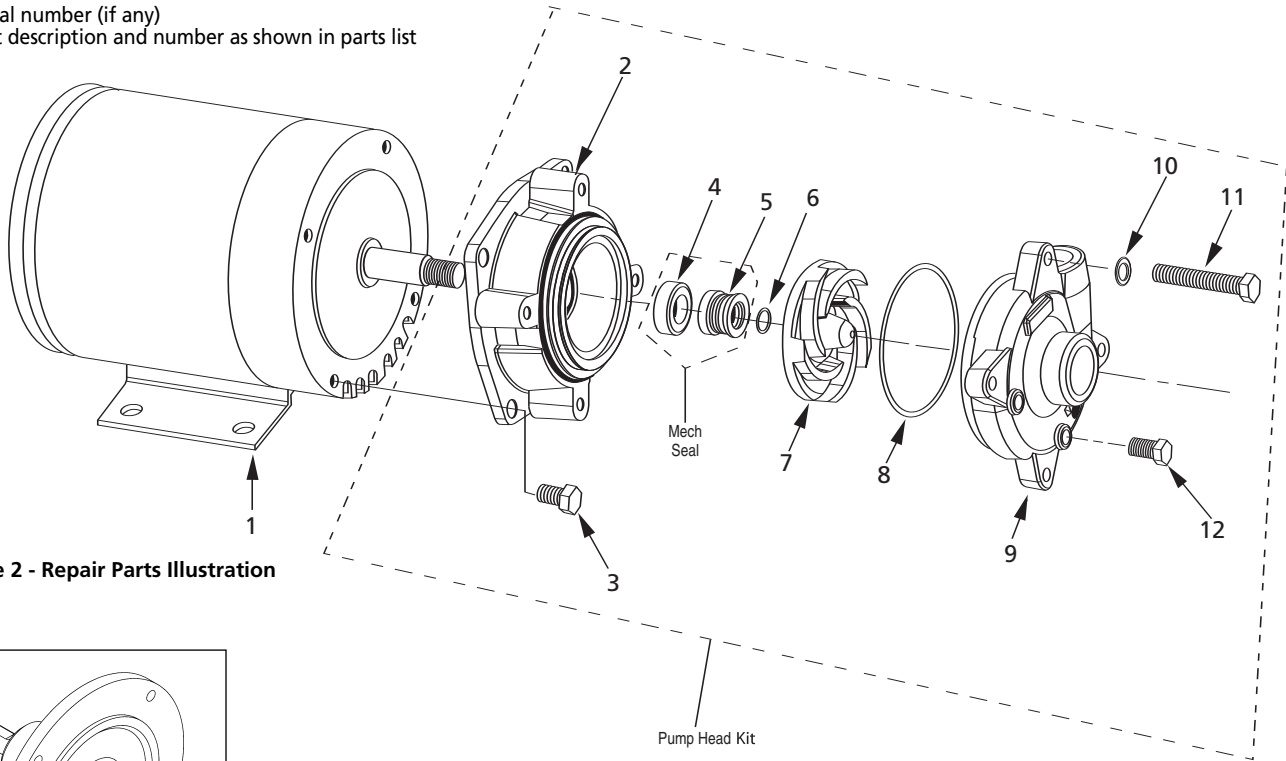
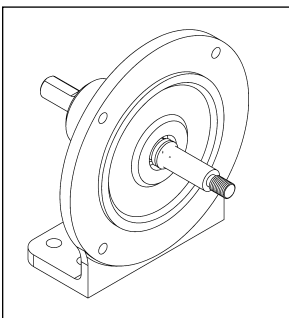

Figure 2 - Repair Parts Illustration



Optional Pedestal Base

ODP and TEFC Replacement Motors

HP	1 Phase ODP P/N	Motor Suffix	3 Phase ODP P/N	Motor Suffix	1 Phase TEFC P/N	Motor Suffix	3 Phase TEFC P/N	Motor Suffix
1/3	14010H	1	NA	13	NA	1T	NA	13T
1/2	14011H	2	24361H	23	24499H	2T	13431H	23T
3/4	14012H	3	14015H	33	13409H	3T	14017H	33T
1	14013H	4	12991H	43	24500H	4T	18741H	43T
1½	14014H	5	14016H	53	13410H	5T	14018H	53T
2	12985H	6	13341H	63	13411H	6T	19495H	63T
3	24364H	7	24365H	73	24366H	7T	23424H	73T

NA = Not Available ODP = Open Drip Proof Motor TEFC = Totally Enclosed Fan Cooled Motor

NOTES: The standard pump and motor combinations are offered with ODP motors which have larger service factors than the same TEFC motor. When mating a TEFC motor to a pump head or replacing an ODP motor with a TEFC motor use one HP rating higher for 1/3, 1/2, 3/4, 1 and 1-1/5 HP motors. Example: Use a 1/2 HP TEFC motor on a COMC1X pump head. The standard model is a COMC11 which uses a 1/3 HP ODP motor.

Do not use TENV motors — Totally-Enclosed Non-Ventilated motors.

Replacement motors come standard with slinger.

316 Stainless Steel, Bronze and Cast Iron Models

Repair Parts List for 316 Stainless Steel Pumps

Ref. No.	Description	Part Number for Models without the Motor Suffix:							Qty.
		COMSV11	COMSV22	COMSV3	COMSV4	COMSV5	COMSV6	COMSV7	
1	Motor *** (See motor chart)	Motor Chart	Motor Chart	Motor Chart	Motor Chart	Motor Chart	Motor Chart	Motor Chart	1
2	Centrifugal body	228675	228685	228685	228885	228885	244985	244985	1
3	Bolt, 3/8-16 UNC x 1, 18-8 SS*	2220-0025	2220-0025	2220-0025	2220-0025	2220-0025	23393	23393	4
	Lockwasher, 3/8", 18-8 SS*	2260-0012	2260-0012	2260-0012	2260-0012	2260-0012	N/A	N/A	4
4 & 5	Viton mechanical seal & seat assy	242765	242765	242765	242765	242765	242765	242765	1
	Option seals available **								1
	† Buna-N mechanical seal & seat assy	242755	242755	242755	242755	242755	242755	242755	1
	†Silicon Carbide seal & seat assy	2120-0039S	2120-0039S	2120-0039S	2120-0039S	2120-0039S	2120-0039S	2120-0039S	1
6	Impeller shim kit	11933	11933	11933	11933	11933	11933	11933	1
7	Impeller	24444S	24445S	24446S	24447S	24448S	23311	23312	1
8	Viton O-ring	23361	23362	23362	23543	23543	18047	18047	1
	† Buna-N O-ring	22848	22849	22849	22889	22889	18046	18046	1
9	Centrifugal housing	22858S	22859S	22859S	22860S	22860S	23309	23364	1
10	Lock washer, 5/16, 316SS *	23402	23402	23402	23402	23402	N/A	N/A	4
	Lock washer, 7/16, 316SS *	N/A	N/A	N/A	N/A	N/A	23428	23428	3
11	5/16-18 Hex head bolt, 316 SS *	23389	23389	23389	23389	23389	N/A	N/A	4
	7/16-14 Long hex head bolt, 316 SS *	N/A	N/A	N/A	N/A	N/A	23392	23426	2
	7/16-14 Short hex head bolt, 316 SS *	N/A	N/A	N/A	N/A	N/A	23391	23392	1
12	Pipe Plug, 1/8 NPTF, 316 SS	24441	24441	24441	24441	24441	24441	24441	2
	Pipe Plug, 1/8 NPTF, 316 SS	N/A	N/A	N/A	N/A	N/A	23394	23394	3
	Pump Head (less motor)	COMSV1X	COMSV2X	COMSV3X	COMSV4X	COMSV5X	COMSV6X	COMSV7X	1
	Optional Pedestal Bracket	24479	(Can be substituted for any motor when a pulley drive or long coupled pump is desired)						

SS = Stainless Steel

(*) Standard hardware item, available locally.

(**) Viton and Buna-N seals have carbon on ceramic faces. Silicon carbide seals have Viton bellows. All seals have 316 SS metal components.

(***) Driver is subject to change without notice, see label on driver for actual specifications.

(†) Optional

Repair Parts List for Bronze Pumps

Ref. No.	Description	Part Number for Models without the Motor Suffix:							Qty.
		COMBB1	COMBB2	COMBB3	COMBB4	COMBB5	COMBB6	COMBB7	
1	Motor *** (See motor chart)	Motor Chart	Motor Chart	Motor Chart	Motor Chart	Motor Chart	Motor Chart	Motor Chart	1
2	Centrifugal body	22867B	22868B	22868B	22888B	22888B	24498B	24498B	1
3	3/8-16 x 1" bolt, 18-8 SS *	2220-0025	2220-0025	2220-0025	2220-0025	2220-0025	11633	11633	4
	3/8 Lock washer, 18-8 SS *	2260-0012	2260-0012	2260-0012	2260-0012	2260-0012	N/A	N/A	4
4 & 5	Buna-N mechanical seal & seat assy	242755	242755	242755	242755	242755	242755	242755	1
	Option seals available **								1
	†Viton mechanical seal & seat assy	242765	242765	242765	242765	242765	242765	242765	1
	†Silicon Carbide seal & seat assy	2120-0039S	2120-0039S	2120-0039S	2120-0039S	2120-0039S	2120-0039S	2120-0039S	1
6	Impeller shim kit	11933	11933	11933	11933	11933	11933	11933	1
7	Impeller	24444B	24445B	24446B	24447B	24448B	18021	15847	1
8	Buna-N O-ring	22848	22849	22849	22889	22889	18046	18046	1
	†Viton O-ring	23361	23362	23362	23543	23543	18047	18047	1
9	Centrifugal housing	22858B	22859B	22859B	22860B	22860B	18020	15837	1
10	Lock washer, 5/16, Steel, Zinc plated *	2260-0002	2260-0002	2260-0002	2260-0002	2260-0002	N/A	N/A	4
	Lock washer, 7/16, Steel, Zinc plated *	N/A	N/A	N/A	N/A	N/A	2260-0010	2260-0010	3
11	5/16-18 Hex head bolt, Steel, Zinc Plated *	2210-0008	2210-0008	2210-0008	2210-0008	2210-0008	N/A	N/A	4
	7/16-14 Long hex head bolt, Steel Zinc Plated *	N/A	N/A	N/A	N/A	N/A	18043	18045	2
	7/16-14 Short hex head bolt, Steel, Zinc Plated *	N/A	N/A	N/A	N/A	N/A	18044	18043	1
12	Pipe Plug, 1/8 NPTF, Brass *	00336	00336	00336	00336	00336	00336	00336	2
	Pipe Plug, 1/4 NPTF, Brass *	N/A	N/A	N/A	N/A	N/A	2406-0019	2406-0019	3
	Pump Head (Less Motor)	COMBB1X	COMBB2X	COMBB3X	COMBB4X	COMBB5X	COMBB6X	COMBB7X	1
	Optional Pedestal Bracket	24479	(Can be substituted for any motor when a pulley drive or long coupled pump is desired)						

SS = Stainless Steel

(*) Standard hardware item, available locally.

(**) Viton and Buna-N seals have carbon on ceramic faces. Silicon carbide seals have Viton bellows. All seals have 316 SS metal components.

(***) Driver is subject to change without notice, see label on driver for actual specifications.

(†) Optional

SHERTECH® Close-Coupled Centrifugal Pumps

316 Stainless Steel, Bronze and Cast Iron Models

Repair Parts List for Cast Iron Pumps

Ref. No.	Description	Part Number for Models without the Motor Suffix:							Qty.
		COMCB1	COMCB2	COMCB3	COMCB4	COMCB5	COMCB6	COMCB7	
1	Motor *** (See motor chart)	Motor Chart	Motor Chart	Motor Chart	Motor Chart	Motor Chart	Motor Chart	Motor Chart	1
2	Centrifugal body	22867C	22868C	22868C	22888C	22888C	24498C	24498C	1
3	3/8-16 x 1" bolt, Steel, Zinc Plated *	2260-0006	2260-0006	2260-0006	2260-0006	2260-0006	N/A	N/A	4
	3/8 Lock washer, Steel Zinc plated *	2220-0004	2220-0004	2220-0004	2220-0004	2220-0004	11633	11633	4
4 & 5	Buna-N mechanical seal & seat assy	242755	242755	242755	242755	242755	242755	242755	1
	Option seals available **								
	†Viton mechanical seal & seat assy	242765	242765	242765	242765	242765	242765	242765	1
	†Silicon Carbide seal & seat assy	2120-0039S	2120-0039S	2120-0039S	2120-0039S	2120-0039S	2120-0039S	2120-0039S	1
6	Impeller shim kit	11933	11933	11933	11933	11933	11933	11933	1
7	Impeller	24444C	24445C	24446C	24447C	24448C	15969	15970	1
8	Buna-N O-ring	22848	22849	22849	22889	22889	18046	18046	1
	†Viton O-ring	23361	23362	23362	23543	23543	18047	18047	1
9	Centrifugal housing	22858C	22859C	22859C	22860C	22860C	15966	15968	1
10	Lock washer, 5/16, Steel, Zinc plated *	2260-0002	2260-0002	2260-0002	2260-0002	2260-0002	15966	15968	4
	Lock washer, 7/16, Steel, Zinc plated *	N/A	N/A	N/A	N/A	N/A	2260-0010	2260-0010	3
11	5/16-18 Hex head bolt, Steel, Zinc Plated *	2210-0008	2210-0008	2210-0008	2210-0008	2210-0008	N/A	N/A	4
	7/16-14 Long hex head bolt, Steel Zinc Plated *	N/A	N/A	N/A	N/A	N/A	18043	18045	2
	7/16-14 Short hex head bolt, Steel, Zinc Plated *	N/A	N/A	N/A	N/A	N/A	18044	18043	1
12	Pipe Plug, 1/8 NPT, Steel Zinc Plated*	23182	23182	23182	23182	23182	23182	23182	2
	Pipe Plug, 1/4 NPT, Steel Zinc Plated*	N/A	N/A	N/A	N/A	N/A	2406-0019	2406-0019	3
	Pump Head (Less Motor)	COMCB1X	COMCB2X	COMCB3X	COMCB4X	COMCB5X	COMCB6X	COMCB7X	1
	Optional Pedestal Bracket	24479	(Can be substituted for any motor when a pulley drive or long coupled pump is desired)						

SS = Stainless Steel

(*) Standard hardware item, available locally.

(**) Viton and Buna-N seals have carbon on ceramic faces. Silicon carbide seals have Viton bellows. All seals have 316 SS metal components.

(***) Driver is subject to change without notice, see label on driver for actual specifications.

(†) Optional

(Optional) Pedestal Pump Mount
Part Number 24479
(Replaces 56J frame motor)
(When long coupling or pulley drive is required)

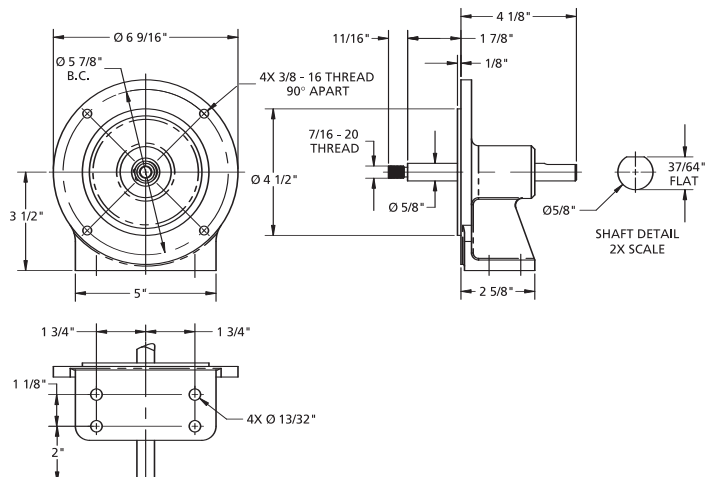

NOTE: Dimensions have a tolerance of $\pm 1/8"$.
 (Ø) Diameter.

316 Stainless Steel, Bronze and Cast Iron Models

Maintenance

⚠ WARNING *Make certain that the unit is disconnected from the power source before attempting to service or remove any components!*

REMOVAL OF OLD SEAL ASSEMBLY

Should the mechanical seal assembly (Ref. No. 4 & 5) require repair, proceed as follows and refer to Figures No. 2 thru 7.

IMPORTANT: Always replace both the seal seat and seal to ensure proper mating of components!

1. Remove bolts (Ref. No. 11) connecting the casing (Ref. No. 9) to the body adapter (Ref. No. 2).
2. Remove the casing.

⚠ CAUTION *Care should be taken not to pinch or "shave" the O-ring gasket (Ref No. 8) between the body adapter and the casing.*

NOTE: Motor shaft must be held in place to remove impeller. Back of the motor either has slot in shaft (use large screwdriver to hold) or has 2 flats on motor shaft (use 7/16" open end wrench to hold). Impeller (Ref. No. 7) unscrew CCW when looking at the front of the pump.

IMPORTANT: Care should be taken to ensure that the same number and thickness of shim washers (Ref. No. 6) are replaced behind the impeller as were removed. The shim washers are located directly behind the impeller and become loose as the impeller is removed.

3. The seal (Ref. No. 5) can now be pulled from the shaft. (See Figure4).
4. Remove the motor body adapter (Ref. No. 2) from the motor by removing the adapter bolts (Ref. No. 3).
5. Use a wooden dowel to push out the seal seat (Ref. No. 4) from the body adapter (Ref. No. 2) (See Figure5).

INSTALLATION OF NEW SEAL ASSEMBLY

⚠ CAUTION *The precision carbon/ceramic faces on the mechanical seal are easily damaged. Handle your repair seal carefully. Do not touch the carbon/ceramic seal faces.*

IMPORTANT: Be sure that shaft shoulder does not damage carbon face.

1. Thoroughly clean all surfaces of the seal seat cavity in body adapter (Ref. No. 2).
2. Using a clean cloth, wipe the shaft and shaft sleeve and make certain that they are perfectly clean.

NOTE: Inspect the motor shaft for scratches or spiral grooves. If they exist, replace motor.

3. Wet the rubber portion of the new seal seat (Ref. No. 4) with a light coating of soapy water. While wearing clean gloves or using a clean light rag, press seal seat squarely into adapter recess. Use the cardboard washer (usually supplied with new seal) to place over the polished surface and use a piece of pipe or dowel rod to press in firmly but gently. Avoid scratching the white ceramic face. (See Figure6).
4. Dispose of cardboard washer. Check again to see that ceramic surface is free of dirt and all other foreign particles and that it has not been scratched or damaged.
5. Wet the inside rubber portion of the new seal (Ref. No. 5) with a light coating of soapy water. Slide seal onto the motor shaft with the sealing surface (carbon) facing the seal seat (See Figure7). This completes seal installation.

NOTE: A short "run-in" period may be necessary to provide completely leak-proof seal operation.

6. Screw impeller (Ref. No. 7) onto shaft. Use screwdriver slot at rear of motor shaft (opposite the threaded end) to tighten impeller. Removable thread fastener should be applied to the impeller threads. Impeller should be torqued to 15 to 18 ft-lbs (180 to 210 in lbs.)

NOTE: It may be necessary to remove plug in motor end cap to expose slot. If removed, be sure to reinstall plug AFTER pump is completely assembled.

7. By replacing the original shims that came with the pump the impeller height should be properly set. The chart accompanying Figure3 gives the correct adapter to motor height dimension for optimum pump performance. After installing check if shaft turns freely by spinning impeller. If rubbing or binding is found, remove impeller and add a shim (Ref. No. 6) to shaft, then recheck. Repeat procedure until all rubbing is eliminated.
8. Place o-ring (Ref. No. 8) on adapter mounting flange. Attach housing using bolts (Ref. No. 11) being careful not to pinch or "shave" o-ring. As the housing is being tightened, periodically spin impeller to check for interference with housing.

⚠ CAUTION *Seal will produce minor drag when spinning motor shaft, but rubbing anywhere else must be eliminated! Otherwise, damage to pump and/or motor may occur.*

IMPELLER CLEARANCE DIMENSIONS

Impeller #	Position "A"
1	0.634"-0.674"
2	0.742"-0.782"
3	0.755"-0.795"
4	0.873"-0.913"
5	0.874"-0.914"
6	0.592"-0.617"
7	0.840"-0.870"

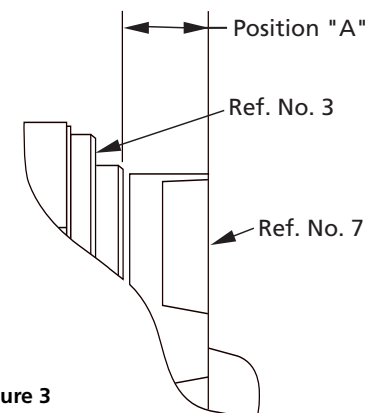

Figure 3

SHERTECH® Close-Coupled Centrifugal Pumps

316 Stainless Steel, Bronze and Cast Iron Models

Seal Assembly Removal and Installation (Figures 4 thru 7)

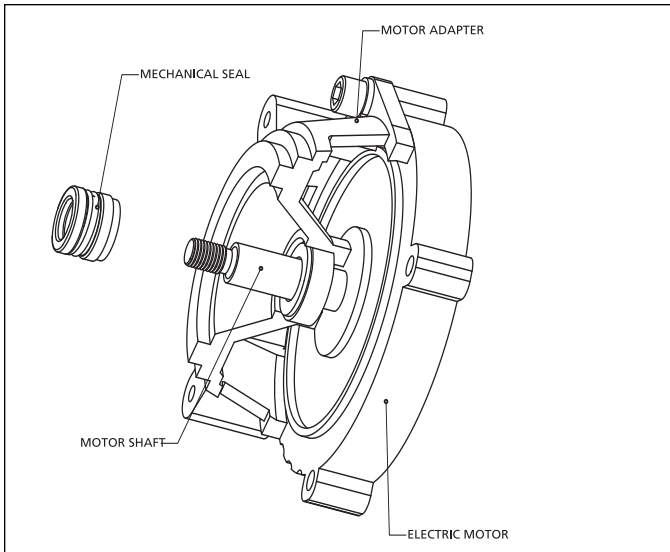

Figure 4 - Seal Removal

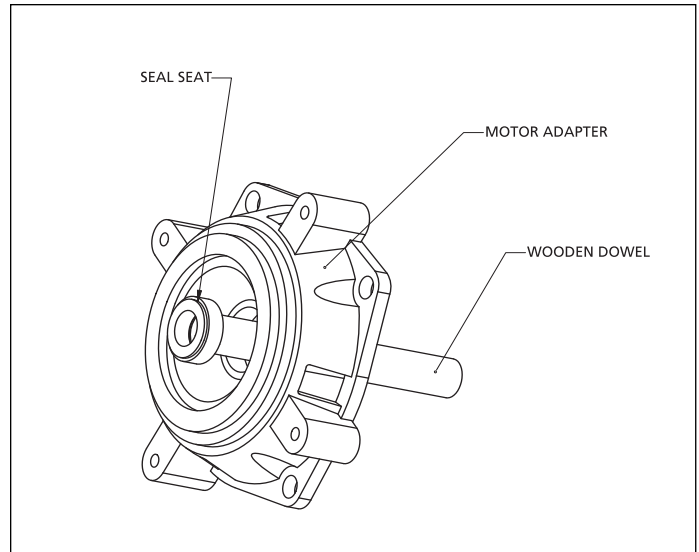

Figure 5 - Seal Seat Removal

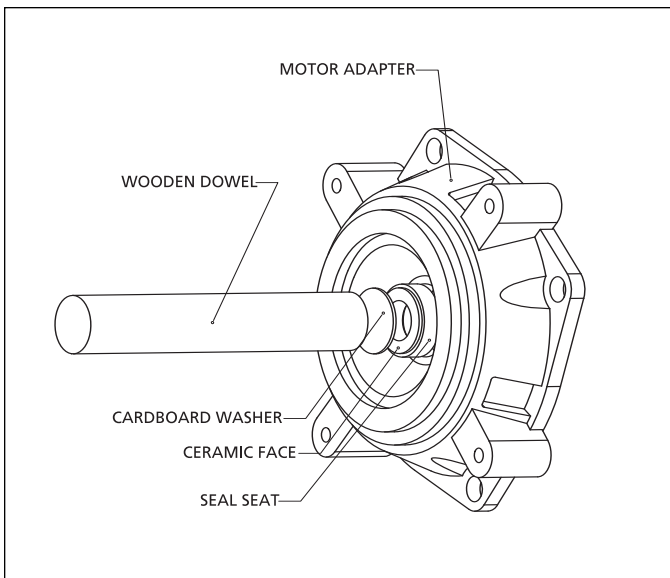

Figure 6 - Seal Seat Assembly

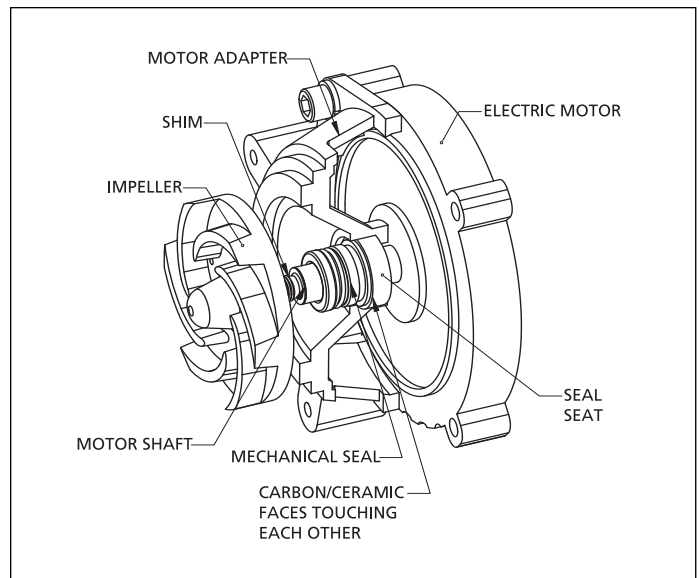

Figure 7 - Seal and Impeller Assembly

316 Stainless Steel, Bronze and Cast Iron Models

Troubleshooting Chart

Symptom	Possible Causes (s)	Corrective Action
Pump runs but no fluid	<ol style="list-style-type: none"> 1. Faulty suction piping 2. Pump located too far from fluid source 3. Gate valve closed 4. Clogged strainer 5. Fouled foot valve 6. Discharge height too great, or long 	<ol style="list-style-type: none"> 1. Replace piping 2. Relocate pump 3. Open valve 4. Clean or replace strainer 5. Clean or replace valve 6. Lower the discharge point shorten piping
Pump will not prime or retain prime after operating	<ol style="list-style-type: none"> 1. Air leak in suction line 2. Clogged foot valve or strainer 3. Leaking foot valve 	<ol style="list-style-type: none"> 1. Repair or replace 2. Clean or replace 3. Repair or replace foot valve
Flow rate is low	<ol style="list-style-type: none"> 1. Piping is fouled or damaged 2. Clogged impeller or worn impeller 3. Discharge line restricted or undersized 4. Plumbing restriction 	<ol style="list-style-type: none"> 1. Clean or replace 2. Clean or replace 3. Flush out piping or replace 4. Remove restrictions
Pump starts and stops pumping	<ol style="list-style-type: none"> 1. Fouled impeller 2. Faulty mechanical seal 3. Leak in suction line 4. Leak in foot valve 	<ol style="list-style-type: none"> 1. Clean impeller and pump 2. Replace seal 3. Repair or replace suction line 4. Repair or replace foot valve
Excessive noise while pump in operation	<ol style="list-style-type: none"> 1. Pump not secured to form foundation 2. Piping not supported to relieve any strain on pump assembly 3. Restricted suction line 	<ol style="list-style-type: none"> 1. Secure pump properly 2. Make necessary adjustments 3. Clean and correct suction line
Liquid drips from point where shaft enters the pump casing, when pump is full of liquid	<ol style="list-style-type: none"> 1. Damaged mechanical seal 2. Temperatures over 210°F – liquid not compatible with seat 	<ol style="list-style-type: none"> 1. Replace (See mechanical seal replacement) 2. Replace with Viton 24276, if suitable
Pump runs but poor performance	<ol style="list-style-type: none"> 1. Check pump rotation to see if it is CCW as viewed from motor face. On three-phase motors, rotation must be checked prior to running pump under load. 	<ol style="list-style-type: none"> 1. On three-phase motors switch any two motor wire leads to reverse rotation.
<p>⚠ WARNING Failure to check rotation before pump is run can result in severe damage to the pump and motor unit.</p>		

SHERTECH® Close-Coupled Centrifugal Pumps 316 Stainless Steel, Bronze and Cast Iron Models

Impeller Identification Chart

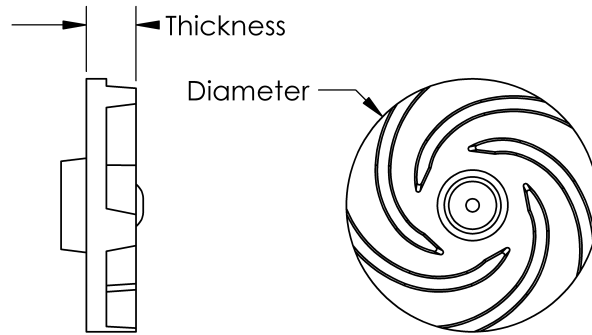

Impeller Identification Chart

Impeller Number	HP Required	316SS Part#	Bronze Part#	Cast Iron Part#	Diameter inches	Thickness inches
1	1/3	24444S	24444B	24444C	3.38	0.60
2	1/2	24445S	24445B	24445C	3.50	0.71
3	3/4	24446S	24446B	24446C	3.63	0.71
4	1	24447S	24447B	24447C	3.90	0.83
5	1-1/2	24448S	24448B	24448C	4.25	0.83
6**	2	23311	18021	19569	4.57	0.52
7**	3	23312	15847	15970	4.63	1.11

NOTES: (**) Tapered impellers
All impellers are semi-open.

SHERTECH®



**Pentair Water
INDUSTRIAL PRODUCTS GROUP**

375 Fifth Avenue NW • New Brighton, MN 55112
Phone: (651) 766-6300 • 800-471-0460 • Fax: 800-672-7023
www.shertech.com • www.hydroindustrial.com