

Please read and save this Repair Parts Manual. Read this manual and the General Operating Instructions carefully before attempting to assemble, install, operate or maintain the product described. Protect yourself and others by observing all safety information. The Safety Instructions are contained in the General Operating Instructions. Failure to comply with the safety instructions accompanying this product could result in personal injury and/or property damage! Retain instructions for future reference.

# **SHERTECH**® Bronze Close-Coupled Self-Priming Flexible Impeller Pumps

Refer to form L-4082 for General Operating and Safety Instructions.

## Description

Shertech bronze self-priming, positive displacement, flexible impeller pumps provide a nearly pulseless flow with no metal-to-metal contact. Features bronze pump body, stainless steel cover and wear plates, 303 stainless steel shaft, standard Nitrile lip-type seals and impellers, and carrying handle for portability. Mounted directly to NEMA frame AC Open Drip-Proof (ODP) motors using an easy-installation package, or as pump heads only for custom installations. Single-phase motors are thermally-overload protected.

Uses: Handle a wide range of industrial, marine, agricultural and commercial applications where non-abrasive fluids compatible with pump wet-end construction component materials are pumped. Pumps are suitable for the transfer of non-lubricating fluids, mild abrasives, fluids containing small particles in suspension, and a wide variety of viscous fluids such as petroleum-based oils, silicone greases, and hydraulic fluids. The portable transfer units are ideal for water drainage transfer, barrel emptying, machine coolant recycling, and an assortment of related utility activities.

**NOTE:** Flexible impeller failure will occur immediately if pump is run dry, and this is not covered under warranty. Use caution to not touch the pump if you have dry run it, because it will be extremely hot.

- Pumps are supplied with 56C face motors and open drip-proof construction.
- Capacities up to 21.2 GPM at 1725 RPM.
- Maximum discharge pressure is 25 PSI (60 ft. of head).
- Max. RPM: 3450 (1725 with supplied motors).
- Suction lift to 10.2 ft.
- Nitrile lip seal and o-rings: Impeller is equipped with a lip seal wear sleeve, providing for a new seal wear surface each time impeller is replaced thus protecting the motor shaft from seal wear.
- Maximum viscosity for pumps with standard electric motors up to 500 SSU and 25 PSI (60 ft. of head) at 1725 RPM or run at reduced speeds to handle a wide range of pump fluid viscosities (up to 2500 SSU) and specific gravity (up to 1.3). DO NOT pump oils or petroleum derivatives with optional neoprene impellers. (Maximum torque loads are found in the performance chart.)
- Pumps can operate bi-directionally (reversible).
- Temperature range with Nitrile impellers is 0°F - 180°F (optional neoprene impeller is 15°F - 130°F).
- NPT ports (1/2" to 1").
- Accessory NPT ports (1/8") for priming, vacuum switch (pump protector) installation (to allow for dry run protection) or pressure gauge installation.

**BRONZE MODELS** – Excellent for water-based fluids. Feature bronze pump body, stainless steel cover and wear plates, 303 stainless steel shaft, standard Nitrile lip-type seals and impellers, and carrying handle for portability. Wet-end parts are constructed from bronze, brass, Nitrile, and 303 and/or other 300 series stainless steel.

**REPAIR IMPELLERS AND OPTIONS** – Standard impellers are Nitrile, and they and the optional neoprene impeller can be located in the repair parts list pages in this manual.

Optional Close-Coupled Gear Speed Reducers are available that mount directly between pump and motor to reduce pump speed for high viscosity or high specific gravity applications (See Appendix 2).

**NOTE:** Bronze flexible impeller pumps are also available as pedestal models for custom installation. They are not equipped with motors.



**WARNING:** Do not use to pump flammable or explosive fluids such as gasoline, fuel oil, kerosene, etc. Do not use in flammable and/or explosive atmospheres. When pumping hazardous or dangerous materials, use only in a room or area designated for that purpose. For your protection, always wear proper clothing, eye protection, etc. in case of any malfunction. For proper handling techniques and cautions, contact your chemical supplier, insurance company and local agencies (fire dept., etc.). Failure to comply with this warning could result in personal injury and/or property damage.

# SHERTECH® Bronze Close-Coupled Self-Priming Flexible Impeller Pumps

## Model Ordering Codes and Options



**Example Model: MRB9901** (1/2 HP ODP motor with >1.15 Service Factor\*)

1st	2nd	3rd	4th	5th	6th
Mounting	Type	Material	Impeller Size (Ports)	Impeller Material	AC Motor Options**
M: Motor Mount	R: Flexible (Rubber) Impeller	B: Bronze and/or Brass Body and Cam with Stainless Steel Wear Plates	90 (1/2"*** - 1/3 HP 99 (3/4" - 1/2 HP 150 (1" - 3/4 HP	0: Nitrile 1: Neoprene	0: Pump only 1: 1725 RPM 2: 3450 RPM

**NOTE:** Not all order code combinations (configurations) are standard models available from the manufacturer. Custom model configurations may require ordering standard components and/or optional parts that will need to be assembled by the customer.

Manufacturer reserves the right to change model order codes, standard models, specifications, and performance without notification. Standard motor speed is 1725 RPM. Maximum motor speed is 3450 RPM.

(\*) ODP motors have > 1.15 service factors. Due to service factor, it is recommended TEFC motors are oversized by one HP increment. Pedestal Pumps are not supplied with a motor.

(\*\*) Standard motors are single phase, 1725 RPM, open drip-proof.

(\*\*\*) Also equipped with external 3/4" male garden hose thread on inlet and outlet ports.

# Models MRB9000, MRB9001, MRB9900, MRB9901, MRB15000 and MRB15001

## Performance (with Water)

Model	*Port Size	HP	GPM Pumping Water at 70° F @ Total Feet of Head										
			Max. Input			Suction		Free Flow	10	20	30	40	50
			Torque in.-lbs.	RPM	Lift***								
<b>Models with Motors</b>													
MRB9001	1/2**	1/3	28	1725	8.1	7.8	7.1	6.7	6.2	5.5	4.8	3.8	
MRB9901	3/4	1/2	37	1725	9.4	12.1	11.9	10.5	9.2	8.6	6.7	5.4	
MRB15001	1	3/4	55	1725	10.2	21.2	20.6	19.5	18.1	16.5	14.7	11.0	
<b>Models without Motors</b>													
MRB9000	1/2**	1/3	28	1725	8.1	7.8	7.1	6.7	6.2	5.5	4.8	3.8	
MRB9900	3/4	1/2	37	1725	9.4	12.1	11.9	10.5	9.2	8.6	6.7	5.4	
MRB15000	1	3/4	55	1725	10.2	21.2	20.6	19.5	18.1	16.5	14.7	11.0	

Test data taken with water at 70° F (to convert data to PSI, divide feet of head by 2.31).

Pump performance when pump is new. As pump wears, the performance will decrease.

(†) Extended operation beyond 60 feet of head will result in immediate impeller failure.

(\*) Female NPT inlet and outlet (in inches).

(\*\*) Also equipped with external 3/4" male garden hose thread on inlet and outlet ports.

(\*\*\*) Suction lift requires wetted impellers and seal chamber.

**NOTES:** Consult tables on HP adders and speed recommendations for high viscosity fluids. The pump relationship between volume (GPM), pressure (PSI), speed (RPM) and horsepower is shown on Performance Chart in Shertech Motor Manual form L-4082. When pumping a more viscous liquid, a slower speed, a larger pipe size pump, and possibly a larger motor should be selected.

Max. Viscosity = 500 SSU at 1725 RPM with the motor supplied (at 1.0 specific gravity).

Max. Input Torque = see chart above.

Max. RPM = 1725

Max. Specific Gravity = 1.0 at 25 PSI, up to 1.3 at lower PSI & viscosity.

Do not use optional Neoprene impellers with oil.

Manufacturer reserves the right to change performance without notification.

## Specifications

Model	Motor HP	AC Motor Type	NEMA Frame	Motor Voltage	Amps	PH	HZ	Overload Protection**	Motor RPM	Pump Shaft Size	Motor Shaft	Motor Adapter	PUMP CONSTRUCTION (Wet End)					Ship Wt. (lbs.)	
													Port (Inches)	Pump Body & Cam	Flexible Impeller ****	Wear Plates	Seal & O-Rings*		
<b>Models with Motors</b>																			
MRB9001	1/3	ODP	56C	115/230	8.2/4.1	1	60	Yes	1725	3/4" Hollow	5/8 Keyed	CI	1/2***	BR & BZ	Nitrile	303 SS	303 SS	Nitrile	27
MRB9901	1/2	ODP	56C	115/230	8.8/4.4	1	60	Yes	1725	3/4" Hollow	5/8 Keyed	CI	3/4	BR & BZ	Nitrile	303 SS	303 SS	Nitrile	31
MRB15001	3/4	ODP	56C	115/230	10.8/5.4	1	60	Yes	1725	3/4" Hollow	5/8 Keyed	CI	1	BR & BZ	Nitrile	303 SS	303 SS	Nitrile	40
<b>Models without Motors</b>																			
MRB9000	-	-	-	-	-	-	-	-	-	3/4" Hollow	-	-	1/2***	BR & BZ	Nitrile	303 SS	303 SS	Nitrile	5
MRB9900	-	-	-	-	-	-	-	-	-	3/4" Hollow	-	-	3/4	BR & BZ	Nitrile	303 SS	303 SS	Nitrile	6
MRB15000	-	-	-	-	-	-	-	-	-	3/4" Hollow	-	-	1	BR & BZ	Nitrile	303 SS	303 SS	Nitrile	7

SS = Stainless Steel CI = Cast Iron ODP = Open Drip-proof BR = Brass BZ = Bronze

(\*) Nitrile lip seal with 300 Stainless Steel Series case and garter spring.

(\*\*) Manual or Automatic - Check motor supplied.

(\*\*\*) Also equipped with external 3/4" male garden hose thread on inlet and outlet ports.

(\*\*\*\*) Impeller has bronze and/or brass insert with a 300 Series Stainless Steel Sleeve insert.

**NOTES:** Driver data is subject to change without notice; see label on driver for actual information.

All dimensions in inches unless otherwise specified.

To prevent dry run operation, a vacuum switch (pump protector) is recommended.

Manufacturer reserves the right to change specifications without notification.

# SHERTECH® Bronze Close-Coupled Self-Priming Flexible Impeller Pumps

## Dimensions

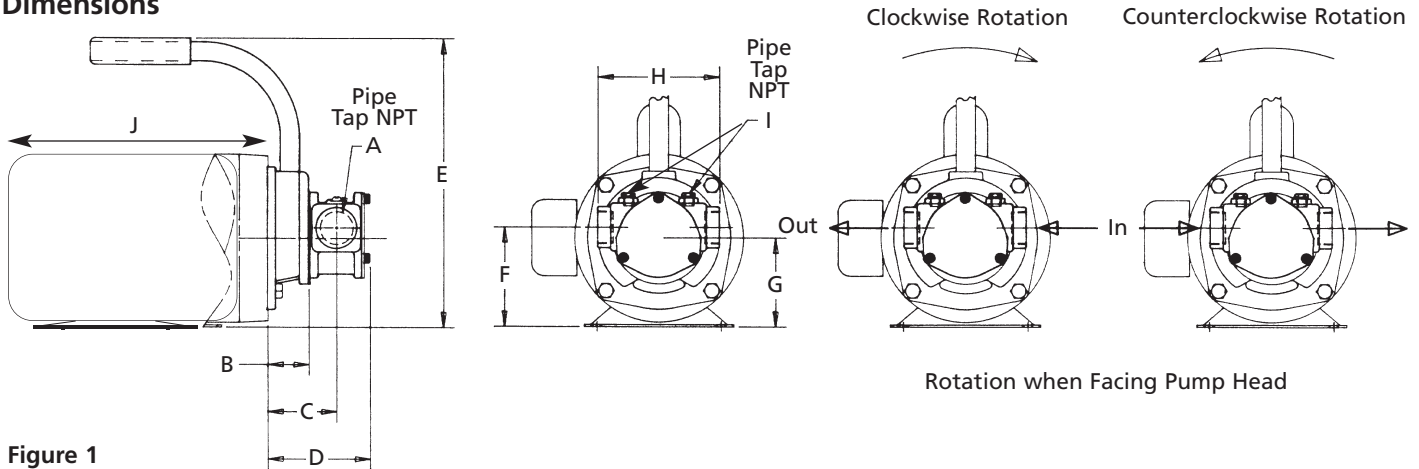

Figure 1

Model	Dimensions (in inches)										
	A*	B	C	D	E	F	G	H	I†	J***	
<b>Models with Motors</b>											
MRB9001	1/3**	1.68	2.17	2.94	11.36	3.91	3.50	6.70	1/8	7.24	
MRB9901	1/2	1.68	2.35	3.32	11.36	3.91	3.50	6.46	1/8	7.93	
MRB15001	3/4	1.68	2.73	4.07	11.36	3.91	3.50	5.05	1/8	8.93	
<b>Models without Motors</b>											
MRB9000	1/3**	1.68	2.17	2.94	11.36	3.91	3.50	6.70	1/8	-	
MRB9900	1/2	1.68	2.35	3.32	11.36	3.91	3.50	6.46	1/8	-	
MRB15000	3/4	1.68	2.73	4.07	11.36	3.91	3.50	5.05	1/8	-	

(\*) Standard NPT (female) pipe thread. Inlet and outlet (in inches).

(\*\*) Also equipped with external 3/4" male garden hose thread on inlet and outlet ports.

(\*\*\*) Electric motor dimensions may vary due to manufacturing specifications. Standard motors are NEMA 56C Open Drip-proof-type with NEMA base.

(†) Standard NPT (female pipe thread) accessory and prime ports on inlet and outlet (in inches).

**NOTE:** All dimensions have a tolerance of (+ or -) 1/8".

Manufacturer reserves the right to change dimensions without notification.

## Impeller Identification Chart

Impeller & Sleeve Part No.	Material	(Dimensions in inches)				Sleeve Dia.	Number of Blades
		Outside Dia.	Width	Hole Dia.	Key slot		
21962S	Neoprene	2.45	0.88	0.63	0.18	0.75	12
21963S	Neoprene	2.45	1.25	0.63	0.18	0.75	12
21964S	Neoprene	2.58	2.00	0.63	0.18	0.75	12
21957S	Nitrile*	2.45	0.88	0.63	0.18	0.75	12
21958S	Nitrile*	2.45	1.25	0.63	0.18	0.75	12
21959S	Nitrile*	2.58	2.00	0.63	0.18	0.75	12

Refer to repair parts list pages in this manual to match up impeller with pump model.

(\*) Nitrile is standard and is equivalent to Buna-N. Nitrile is suggested for pumping oil-based fluids, and Neoprene is suggested for pumping water-based fluids.

**NOTES:** Dry running will result in immediate failure of impeller and cause extreme pump temperature (do not handle pump when hot).

Impeller damage is not covered under warranty.

Manufacturer reserves the right to change dimensions without notification.

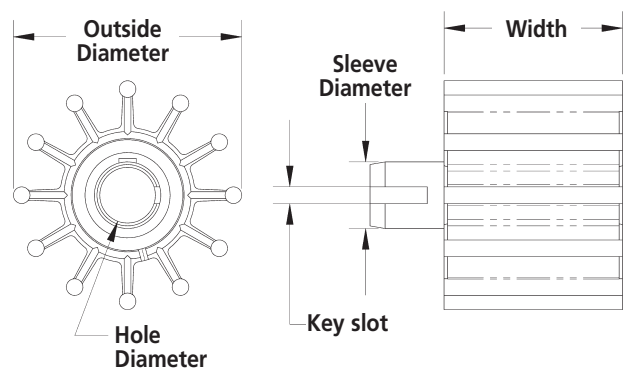

# Models MRB9000, MRB9001, MRB9900, MRB9901, MRB15000 and MRB15001

**⚠ WARNING** Check motor. It may be equipped with an automatic resetting thermal protector and may restart unexpectedly (see specifications chart). Protector tripping is an indication of motor overloading as a result of operating the pump at too high a pressure (over 25 PSI or 60 feet of head), too high of viscosity, too high of specific gravity, excessively high or low voltage, inadequate wiring, incorrect motor connections, too small a motor (sized incorrectly, not enough HP), or a defective motor or pump.

Do not handle pump with wet hands or when standing in water. Failure to follow the General Safety Information and all warnings could result in fatal electrical shock!

## Installation

**IMPORTANT:** In any installations where property damage and/or personal injury can occur when the pump is not operating due to power outages, discharge line freezing, or any other reason, a back-up system(s) and/or warning system(s) should be used.

In order to safely use this product, familiarize yourself with this pump and also with the liquid (chemical, etc.) that is going to be pumped through the unit. This pump is not suitable for many liquids.

1. Locate the pump as close to the liquid source as possible, making the suction line as short and direct as possible.

## PIPING

### SUCTION

2. Avoid excessive lengths or number of fittings and bends in the suction line.
3. Attach suction line to suction inlet (See Figure 1 for proper rotation).

**NOTE:** An optional vacuum switch (pump protector) is recommended to prevent pump dry run. It should be mounted on the suction side of the pump. Refer to installation/operation instructions provided with vacuum switch (See Figure 2).

Figure 2 - Vacuum Switch Installation



4. It is recommended that same size pipe as pump ports be used or, in cases requiring lengthy piping, the next larger size pipe be used.
5. If suction level is greater than what is indicated in the performance chart, attach a foot valve below liquid level at end of suction line to ensure positive priming. Also note: If fluid specific gravity is greater than 1.0 or viscosity greater than 500 SSU, a foot valve is also recommended.

**NOTE:** If a foot valve (or check valve) is not used in the suction line, it may be necessary to refill the pump every time the unit is stopped and you wish to restart the pump. This depends on the length of time between starts and whether or not the impeller is wet enough to close cavities to affect a prime.

6. If solid contaminants are suspected in a liquid, place a filter in the suction line.
7. Be certain all suction piping connections are airtight.

**NOTE:** Assure airtight pipe connections with the use of a pipe joint sealant.

### DISCHARGE

8. Attach discharge piping to the discharge outlet.

**⚠ WARNING** Support pump and piping during assembly and after installation. Failure to do so may cause piping to break, pump to fail, motor bearing failures, etc., all of which can result in property damage and/or personal injury.

**NOTE:** Should the pump need to be self-draining, the pump head should be mounted in the vertical position with the suction port facing down. When pumping high viscosity fluids, the vertical position can be used with the suction port facing up and the pump mounted under the source. Increasing the suction pipe size and eliminating bends and elbows also assists in pumping high viscosity fluids. Max. viscosity is 500 SSU at 1725 RPM.

9. If a shut-off valve or handgun is required in discharge line, provide a pressure relief valve for pump protection.

**⚠ WARNING** Shutting off discharge without providing pressure relief can cause extreme overpressure which can result in pump and/or motor failure. Do not exceed 25 PSI (or 60 feet of head) pump or system pressure.

10. Operation under shut-off discharge conditions will overheat and damage pump and impeller.

**NOTE:** Globe valve or other restrictive valves should not be used as shut-off mechanism as they are restrictive in nature and will seriously affect pump performance.

11. After all piping and controls (not supplied with unit) have been installed, unit is ready for operation.

## Operation

**⚠ WARNING** Do not run pump dry, as permanent damage to the pump impeller, seal, pump housing and wear plates will result. Suction pressure should never be greater than the discharge pressure. Dry running will result in immediate failure of impeller and cause extreme pump temperature (do not handle pump when hot). Impeller damage is not covered under warranty.

# SHERTECH® Bronze Close-Coupled Self-Priming Flexible Impeller Pumps

## Operation (Continued)

1. All pumps must be primed before start-up and filled with fluid (See Figure 3). Never operate a pump unless it is secured to a solid foundation and all safety shields are installed.

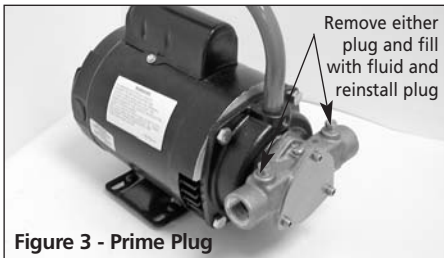

Figure 3 - Prime Plug

Upon start-up, maintain a minimum of 15 PSI (1 BAR) operating pressure on the pump. This will allow any remaining air to be driven from the seal chamber and will ensure liquid circulation to the seal.

2. Flexible impeller pumps are built to very close tolerances and this tolerance must not be altered. The liquids must, therefore, be free of all abrasives. Sand, silt, wettable powders, etc. must be avoided.
3. When pumping a more viscous (beyond 500 SSU) liquid; a slower speed, a larger pipe size pump, and possibly a larger motor should be selected.

**NOTE:** See performance chart for Max. Torque.

4. Recheck motor and pump rotation. Pump rotation is by-directional (See Figure 1).

## PRESSURE RELIEF VALVE

5. Standard models do not include a pressure relief valve. If discharge is going to be shut off, an external pressure relief valve should be installed.

## GEAR SPEED REDUCER OPTIONS

A gear reducer can be directly mounted between a standard pump and motor

combination. Gear speed reducers are available for applications with high specific gravity, or when viscosities are greater than 500 SSU, using a standard 1725 RPM motor (See Appendix 2). The pump relationship between volume (GPM), pressure (PSI), speed (RPM), viscosity, specific gravity and horsepower is shown on performance chart in Shertech Motor Manual form L-4082.

6. Unit is ready for operation.

## Maintenance

**⚠ WARNING** *Make certain that the power source is disconnected before attempting to service or disassemble any components!*

*If the power disconnect is out of sight, lock it in the open position and tag to prevent application of power.*

## CLEANING

Clean the suction line filter at regular intervals.

## ELECTRIC MOTOR

Properly selected and installed, electric motors are capable of operating for years with minimal maintenance. Periodically clean dirt accumulations from open-type motors, especially in and around vent openings, preferably by vacuuming (avoid imbedding dirt in windings). Oil and maintain as recommended by motor manufacturer.

## GENERAL

Check the pump to motor shaft coupler alignment at regular intervals. Periodically check that electrical connections are tight. Pump should be drained if placed in an area that is subject to freezing temperatures and should not be operated until temperature permits.

To store the pump, place a small quantity of light oil or some other storage preservative, compatible with your application, in the pump and rotate the shaft very slowly to work the oil throughout the gears and the body.

## PUMP REPAIR

### IMPELLER DISASSEMBLY

Refer to Figure 9.

**NOTE:** The impeller is a common wear item in this pump and frequent replacement is suggested. Impeller can become torn, distorted and overheated becoming brittle. When this happens, impeller blade fragments can come off the impeller and be pumped downstream or block pump ports or plumbing. (See Appendix 1 for illustrations of common impeller and pump problems.)

- 1a. Remove the three screws (Ref. No. 1) which hold the cover plate (Ref. No. 2) and o-ring (Ref. No. 10) to pump body (Ref. No. 3).
- b. Orient the pump shaft so the set screw on the collar (Ref. No. 20) is visible through the bottom of the motor adapter (Ref. No. 17). Loosen set screw on collar (Ref. No. 20) (See Figure 4).

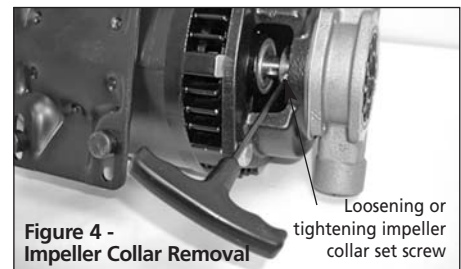

Figure 4 - Impeller Collar Removal

- c. The impeller and sleeve assembly (Ref. No. 12) can be removed using two pair of pliers to grip two of the impeller's vanes on opposite sides of the impeller (See Figure 5).

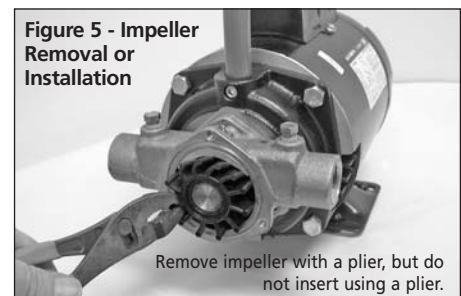

Figure 5 - Impeller Removal or Installation

# Models MRB9000, MRB9001, MRB9900, MRB9901, MRB15000 and MRB15001

d. Inspect cover and internal wear plate, pump body inside and cam for wear. If parts are worn, replace, as worn parts will cause poor pump performance including poor suction lift, discharge pressure and flow. If numerous components are worn, it's suggested to replace the complete pump head. (See Pump and Seal Disassembly section for further pump disassembly instructions.)

## IMPELLER ASSEMBLY

- 2a. Place some anti-seize compound on motor shaft. Install the impeller and shaft assembly (Ref. No. 12) over the motor shaft using a non-petroleum-based lubricant such as silicone or soapy water. The impeller and shaft assembly is installed using a twisting motion in the same direction as motor rotation (See Figure 5).
- b. Orient the pump and motor shaft key slots so the key slots are visible from bottom of motor adapter (Ref. No. 17). Place key (Ref. No. 14) into key slot of pump and motor shaft. Place collar set screw over key but do not tighten. Tightening the set screw is the last step of impeller assembly (See Figure 6).

Align key in impeller sleeve slot over motor shaft and tighten set screw on collar on top of key.

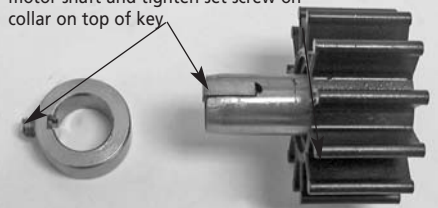

Figure 6 - Impeller Key Installation

**NOTE:** Tightening the impeller sleeve collar before installing the pump cover will result in improper alignment of impeller inside pump body. The pump cover centers the impeller in the pump body, therefore tightening the impeller collar is the last step of assembly.

- c. Install o-ring (Ref. No. 10) into housing groove and put cover (Ref. No. 2) on housing being sure not to pinch o-ring. Tighten the three socket head screws (Ref. No. 1) to 36 in.-lbs.
- d. Tightening the collar set screw is the last step of impeller assembly (See Figure 6). Ensure collar set screw tightens on the key and not against impeller sleeve as burrs may occur on the sleeve resulting in future disassembly problems (See Figure 4).

## PUMP AND SEAL DISASSEMBLY

- 3a. Remove impeller and shaft assembly (Ref. No. 12). (See Impeller Disassembly.)

**NOTE:** This step is provided for cam (Ref. No. 5) removal, but is not necessary to remove the lip seal unless cam or pump body are worn.

- b. Remove cam screw (Ref. No. 4) and cam washer (Ref. No. 11) to remove cam (Ref. No. 5) (See Figure 7).



Figure 7 - Cam Inspection, Removal and Installation

- c. Remove the four bolts (Ref. No. 19) holding pump assembly to motor face. Pump assembly can now be readily removed from the motor.
- d. Remove screw (Ref. No. 21). Handle can now be removed.
- e. Remove three screws (Ref. No. 7) which retain pump body (Ref. No. 3), o-ring (Ref. No. 10), motor adapter (Ref. No. 17), and wear plate (Ref. No. 16).
- f. Press out lip seal (Ref. No. 15) from motor adapter (Ref. No. 17) bore.
- g. Remove o-ring (Ref. No. 13) from motor adapter.

## PUMP AND SEAL ASSEMBLY

- 4a. Press lip seal (Ref. No. 15) into the motor adapter bore with lip facing toward the housing (Ref. No. 3). Press seal evenly and flush to the face of the motor adapter. An o-ring groove will be formed between the lip seal and motor adapter. Place o-ring (Ref. No. 13) in this groove (See Figure 8).



- b. Place wear plate (Ref. No. 16) on adapter (Ref. No. 17) (See Figure 8). Put the o-ring (Ref. No. 10) into pump body (Ref. No. 3) groove. Bolt pump body to motor adapter with three socket head screws (Ref. No. 7) being sure not to pinch either of the o-rings.
- c. Place cam (Ref. No. 5) into housing (Ref. No. 3) bore. Place cam washer (Ref. No. 11) on cam screw (Ref. No. 4) and screw into cam through the housing (Ref. No. 3). Align cam straight, and tighten cam screw to 36 to 48 in.-lbs.
- d. Install impeller and shaft assembly (See Impeller Assembly).
- e. All pumps must be primed before start-up and filled with fluid (See Figure 3). Never operate a pump unless it is secured to a solid foundation and all safety shields are installed.

### **WARNING**

**Do not run pump dry, as permanent damage to the pump impellers, seal, pump housing and wear plates will result. Suction pressure should never be greater than the discharge pressure. Dry running will result in immediate failure of impeller and cause extreme pump temperature (do not handle pump when hot). Impeller damage is not covered under warranty.**

## Contact a Shertech Distributor

Distributors can be found at [www.shertech.com](http://www.shertech.com) or [www.hyproindustrial.com](http://www.hyproindustrial.com)

(The factory only sells pumps and parts to distributors.)

Please provide following information:

- Model number
- Serial number (if any)
- Part description and number as shown in parts list

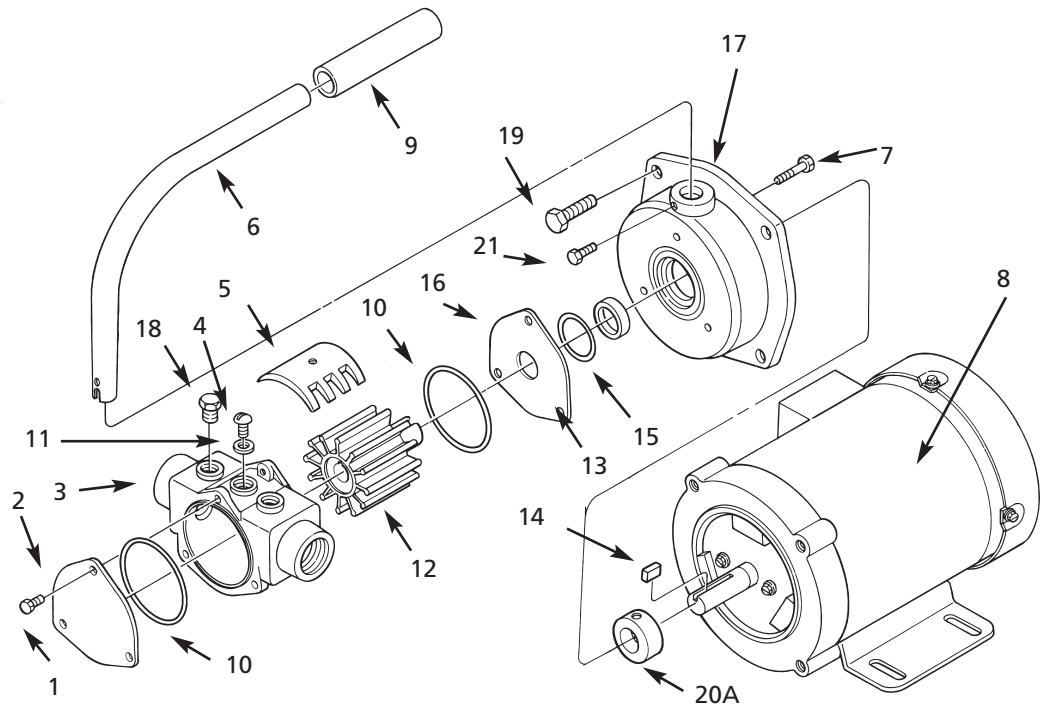

Figure 9 - Repair Parts Illustration

Ref. No.	Description	Part No. for Pump Models						Qty.
		MRB9001	MRB9901	MRB15001	MRB9000	MRB9900	MRB15000	
1	Screw	21733	21733	21733	21733	21733	21733	3
2	Cover Plate (303 Stainless Steel)	21173	21173	21173	21173	21173	21173	1
3	Pump Body (Bronze or Brass)	21617	21618	21619	21617	21618	21619	1
4	Cam Screw	21727	19995	19995	21727	19995	19995	1
5	Cam (Brass or Bronze)	21726	15883	18314	21726	15883	18314	1
6	Handle	21724	21724	21724	21724	21724	21724	1
7	Screw	22049	22049	22049	22049	22049	22049	3
8	Motor (Open Drip-Proof, 1-Phase)	217205	217215	217225	-	-	-	1
9	Grip Handle	21725	21725	21725	21725	21725	21725	1
10	O-ring (Nitrile)	12231	12231	12231	12231	12231	12231	2
11	Washer (Copper)	21997	19996	19996	21997	19996	19996	1
12	† Impeller and Sleeve Assembly (Nitrile)	219575	219585	219595	219575	219585	219595	1
Optional	† Impeller and Sleeve Assembly (Neoprene)	219625	219635	219645	219625	219635	219645	1
13	O-ring (Nitrile)	21303	21303	21303	21303	21303	21303	1
14	Key (Impeller Sleeve Motor Drive Key)	21597	21597	21597	21597	21597	21597	1
15	* Lip Seal (Nitrile)	21622	21622	21622	21622	21622	21622	1
16	Wear Plate (303 Stainless Steel)	21621	21621	21621	21621	21621	21621	1
17	Motor Adapter (Cast Iron)	21620	21620	21620	21620	21620	21620	1
18	Drain Plug (300 Stainless Steel or Brass)	00336	00336	00336	00336	00336	00336	2
19	Screw	22771	22771	22771	22771	22771	22771	4
20A	Collar (Impeller Sleeve Collar)	21995	21995	21995	21995	21995	21995	1
20B	Collar Screw (not pictured)	2230-0002	2230-0002	2230-0002	2230-0002	2230-0002	2230-0002	1
21	Screw	22248	22248	22248	22248	22248	22248	1
22	Motor Base Rubber Pads (not pictured)	1450-0003	1450-0003	1450-0003	1450-0003	1450-0003	1450-0003	4

(\*) Standard Shaft Lip Seals have 300 Series Cases and Garter Springs.

(†) Impeller has bronze and/or brass insert with a 300 Series Stainless Steel Sleeve insert. Impeller sleeve and impeller cannot be purchased separately. Manufacturer reserves the right to change parts without notification.

# Models MRB9000, MRB9001, MRB9900, MRB9901, MRB15000 and MRB15001

## Appendix 1 - Impeller Pump Inspection, Common Problems and Operation

Shertech recommends replacing your impeller annually. Proper storage of the impellers during a prolonged lay-up can help maintain the life of the impeller.

Remove the impeller from the housing and store it in a cool, dark place. This will avoid the following:

- Copper bonding of the impeller to the housing
- Vanes "setting" into position as stored in the housing
- Ultraviolet deterioration

### Recommended inspection to be performed at any service interval:

Impeller . . . . . Inspect for cracks or tears. Also, inspect for excessive abrasion of vane ends. Replace annually or if any of the conditions exist (see picture).

Wear Plate . . . . . Inspect for wear, flatness, and pin for fatigue. Replace at minor and major pump rebuild or if wear is evident to maintain pump flow and suction performance.

Cam . . . . . Replace at major pump rebuild or if pitting/wear is evident.

Cover . . . . . Replace at major pump rebuild or if wear exists to maintain pump flow and suction performance.

Mechanical Seal . . . . . Replace at minor and major pump rebuild or if leaking.

Lip Seal . . . . . Replace at minor and major pump rebuild or if leaking.

Shaft . . . . . Inspect for wear in area of lip seal and rubber impeller. Grooving of lip seal area or heavy fretting of the impeller end shaft will require shaft replacement.

Bearing . . . . . Inspect for loss of grease, corrosion or rough rotation. Replace at major pump rebuild or if in doubt.

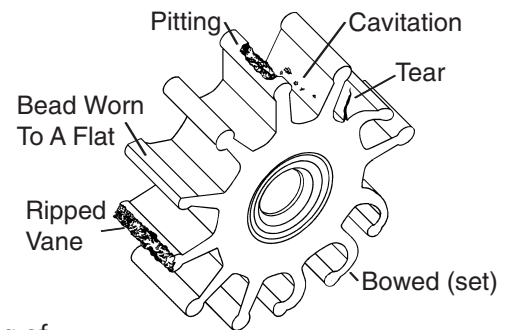

### Three tips to help you install your new Shertech impeller:

- Use a non-petroleum-based lubricant (silicone or soapy water) to help slide the impeller into the housing.
- Install the impeller with a twisting motion onto the shaft. Never force an impeller onto the shaft.
- Impeller must be able to move freely on the shaft to properly prime and function.

(Use a small amount of non-petroleum-based lubricant to help hold the o-ring or gasket when replacing the cover.)

## Operation: How an Impeller Pump Works

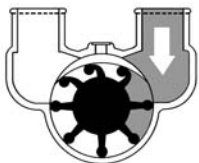

**1** A self-priming vacuum is created as the flexible impeller vanes straighten upon leaving the cam, drawing liquid into the pump.

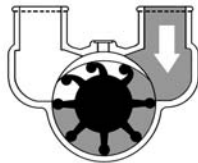

**2** The rotating impeller carries liquid from the inlet to the outlet port.

As a consequence of their design, flexible impeller pumps can pass fairly large solids.

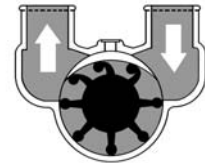

**3** When the flexible impeller vanes regain contact with the cam, they bend and the liquid is discharged from the pump in a uniform flow.

Liquids can be pumped in the opposite direction by reversing the rotation of the pump.

# SHERTECH® Bronze Close-Coupled Self-Priming Flexible Impeller Pumps

## Appendix 2 - Optional C-Flanged Pump Speed Gear Reducers

### GEAR SPEED REDUCER OPTIONS

A gear reducer can be directly mounted between a standard pump and motor combination. Gear speed reducers are available for applications with high

specific gravity, or when viscosities are greater than 500 SSU, using a standard 1725 RPM motor. The pump relationship between volume (GPM), pressure (PSI), speed (RPM), viscosity, specific

gravity and horsepower is shown on performance chart in Shertech Motor Manual form L-4082.

Model Number	Description	L*	M*	RPM Out**	Ship Weight (lbs.)
AGR56C600	Gear Reducer, 56C to 56C, 3.0 ratio	5.177	1.675	583	21
AGR56C900	Gear Reducer, 56C to 56C, 2.0 ratio	5.177	1.675	875	21
AGR56C1200	Gear Reducer, 56C to 56C, 1.5 ratio	5.177	1.675	1167	21

(\*) L dimension (in inches) is length of the gear reducer. M dimension (in inches) is the offset of the reducer output centerline from the motor centerline. All reducers may be rotated in 90° increments changing the orientation of the offset from top to side to bottom.

(\*\*) Based on 1750 RPM motor speed.

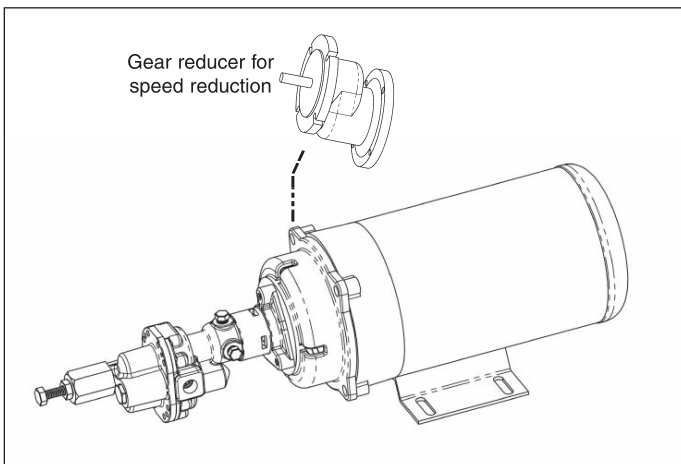

Disassemble Pump From Motor and Insert Gear Reducer. Illustration depicts gear pump but same principle applies to flexible impeller pumps.

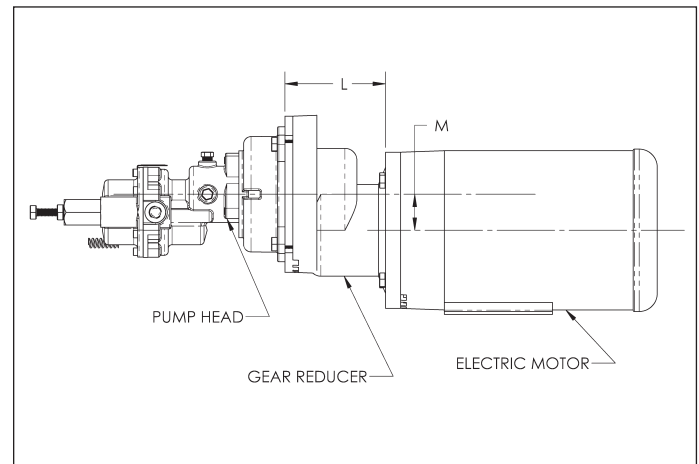

Gear Reducer Installed between Pump and Motor (References L and M are dimensions in chart above.) Illustration depicts gear pump but same principle applies to flexible impeller pumps.



# Limited Warranty on **SHERTECH**® Bronze Close-Coupled Self-Priming Flexible Impeller Pumps

Hypro warrants to the original purchaser of its products (the "Purchaser") that such products will be free from defects in material and workmanship under normal use for the period of six (6) months, and accessories will be free from defects in material and workmanship under normal use for the period of ninety (90) days. Parts carry no warranty.

"Normal use" does not include use in excess of recommended maximum speeds, pressures, vacuums and temperatures, or use requiring handling of fluids not compatible with component materials. This warranty does not cover freight damage, freezing damage, pump or motor damage from incorrect wiring (if equipped with motor), normal wear and tear, or damage caused by misapplication, fault, negligence, alterations, dry running pump, or repair that affects the performance or reliability of the product.

**THIS WARRANTY IS EXCLUSIVE. HYPRO MAKES NO OTHER WARRANTY, EXPRESS OR IMPLIED, INCLUDING BUT NOT LIMITED TO ANY WARRANTY OF MERCHANTABILITY OR FITNESS FOR A PARTICULAR PURPOSE.**

Hypro's obligation under this warranty is, at Hypro's option, to either repair or replace the product upon return of the entire product to the Hypro factory in accordance with the return procedures set forth below. **THIS IS THE EXCLUSIVE REMEDY FOR ANY BREACH OF WARRANTY.**

**IN NO EVENT SHALL HYPRO BE LIABLE FOR ANY INCIDENTAL OR CONSEQUENTIAL DAMAGES OF ANY KIND, WHETHER FOR BREACH OF ANY WARRANTY, FOR NEGLIGENCE, ON THE BASIS OF STRICT LIABILITY, OR OTHERWISE.**

Only authorized distributors can return products for Warranty. Contact your distributor or visit [www.shertech.com](http://www.shertech.com) to find a distributor for product support.

Distributors can obtain an RMA # and contact person's name by contacting Hypro's customer service at 800-471-0460.

## Return Procedures for Distributors

All pumps or products must be flushed of any chemical (ref. OSHA Section 0910.1200 (d)(e)(f)(g)(h) and hazardous chemicals must be labeled before being shipped\* to Hypro for service or warranty consideration. Hypro reserves the right to request a Material Safety Data sheet from the Purchaser for any pump or product Hypro deems necessary. Hypro reserves the right to "disposition as scrap" pumps or products returned without authorization and/or which contain unknown substances, or to charge for any and all costs incurred for chemical testing and proper disposal of components containing unknown substances. Hypro requests this in order to protect the environment and personnel from the hazards of handling unknown substances.

Be prepared to give Hypro full details of the problem, including the following information:

1. Model number, sale record/invoice, purchase date and from whom you purchased your pump.
2. A brief description of the pump problem, including the following:
  - Liquid pumped. State the pH and any non-soluble materials, and give the generic or trade name.
  - Temperature of the liquid and ambient environment.
  - Suction lift or vacuum (measured at the pump).
  - Discharge pressure.
  - Size, type, and mesh of the suction strainer.
  - Abrasiveness or particulate size in fluids.
  - Drive type (gas engine/electric motor; direct/belt drive; tractor PTO) and rpm of pump.
  - Viscosity of fluid if other than water.
  - Specific gravity of fluid if other than water.
  - Elevation from the pump to the discharge point.
  - Size and material of suction and discharge line.

Hypro may request additional information and may require a sketch to illustrate the problem. Distributors should contact the factory to receive a return material authorization before sending the product. All pumps returned for warranty work should be sent shipping charges prepaid to:

[RMA# and Contact Person]  
HYPRO  
375 Fifth Avenue NW  
New Brighton, Minnesota 55112

**NOTE:** Hypro reserves the right to "disposition as scrap" pumps or products returned without authorization.

\*Carriers, including U.S.P.S., airlines, UPS, ground freight, etc., require specific identification of any hazardous materials being shipped. Failure to do so may result in a substantial fine and/or prison term. Check with your shipping company for specific instructions.

# SHERTECH®



**Pentair Water  
INDUSTRIAL PRODUCTS GROUP**

375 Fifth Avenue NW • New Brighton, MN 55112  
Phone: (651) 766-6300 • 800-471-0460 • Fax: 800-672-7023  
[www.shertech.com](http://www.shertech.com) • [www.hyproindustrial.com](http://www.hyproindustrial.com)