

PARTS LIST

ITEM	PART No.	DESCRIPTION	QTY
01	21150	HOUSING	1
02	10929	CAM	1
03	13285	TAG	1
04	19996	SEAL WASHER	1
05	19995	CAM SCREW	1
06	12857	HEX HD.BOLT 1/4-20x7/8	6
07	12710	LOCKWASHER - 1/4	6
08	6333	BUSHING	1
09	12211	BEARING	1
10	4259	INT.RET.RING	2
11	22141	BODY	1
12	21208	LIP SEAL	1
13	4258	EXT.RET.RING	3
14	22142	WEAR PLATE	1
15	10615	IMPELLER	1
16	4432	KEY	1
17	12231	O-RING	2
18	22140	COVER	1
19	21056	DOWEL PINS	4
20	22143	SHAFT	1
21			
22	22117	SEAL SEAT ASSY	1
23	17653	BAG	1
24	17659	CARTON	1
25	12209	LABEL	1
26	4264	WASHER	1
27	22013	MINOR SERVICE KIT	SERV.
28	22276	MAJOR SERVICE KIT	SERV.

TORQUE VALUES

DET.No 5	6.9 N.m(5.1 Ft.lb)
Det.No 6	6.8 N.m(5.0 Ft.lb)
DET.No 19	6.8 N.m(5.0 Ft.lb)

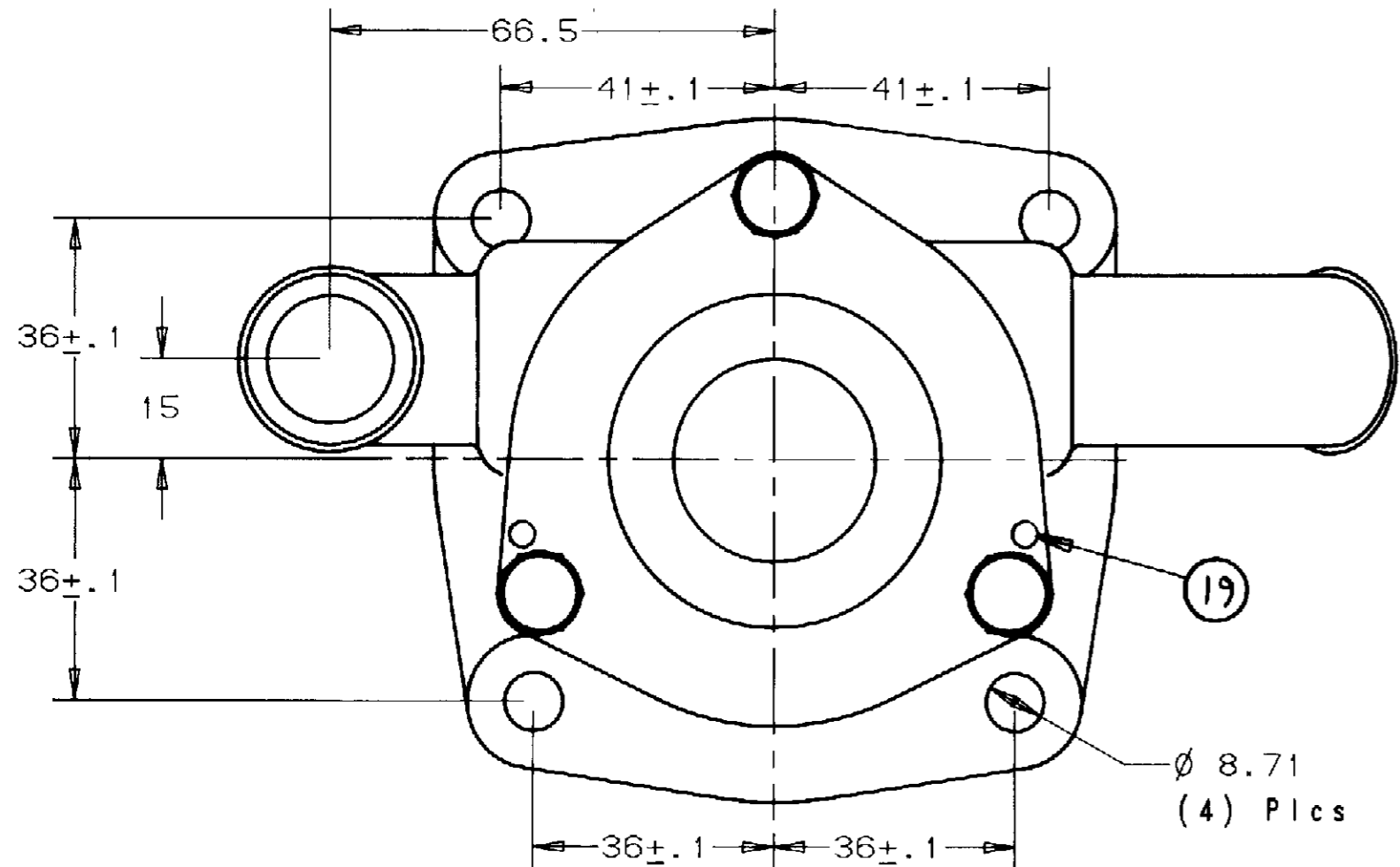
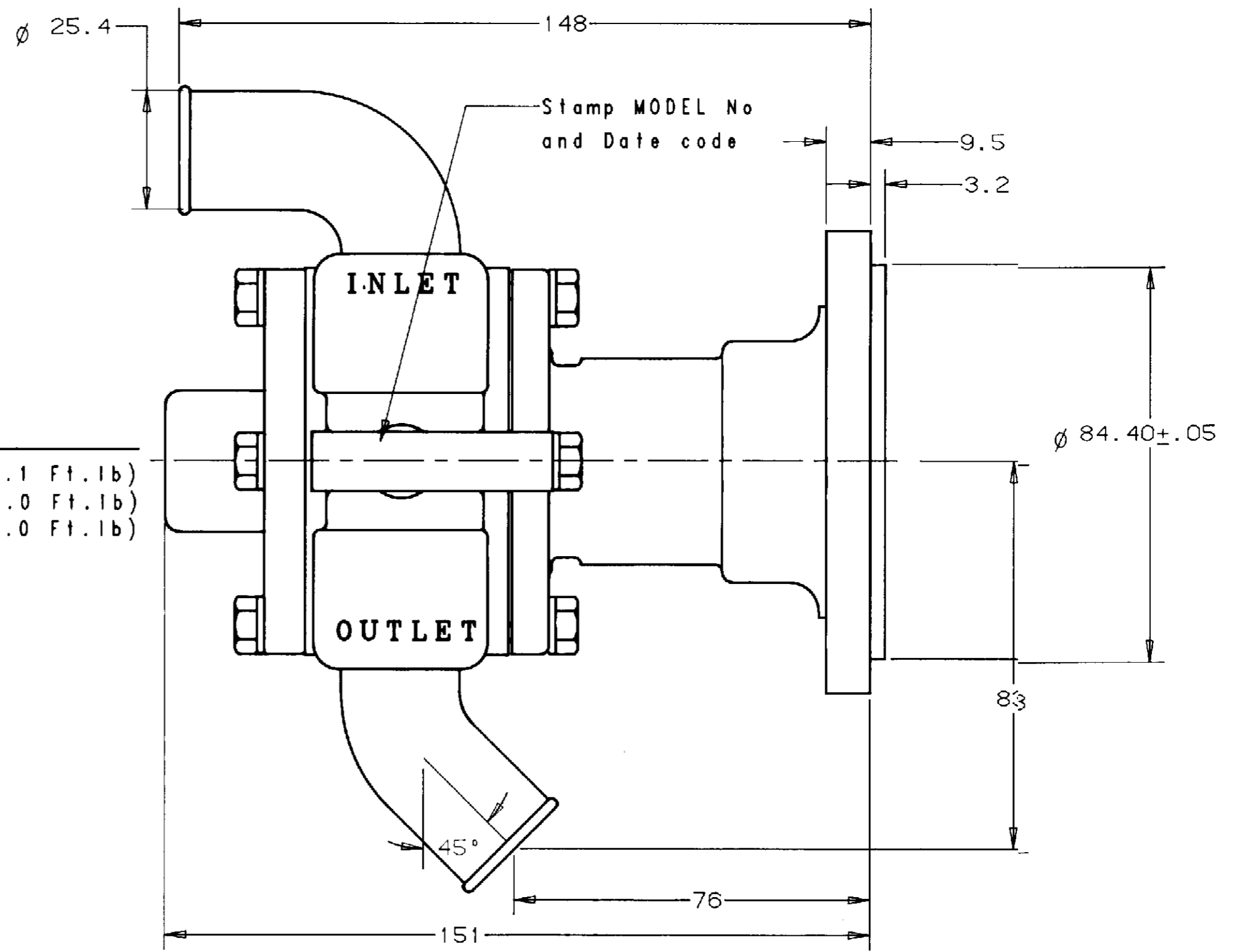

Notes:

1) Details No 6 are to be tightened in an even manner, resulting in a consistent gap between Detail No 12 and Detail No 1.

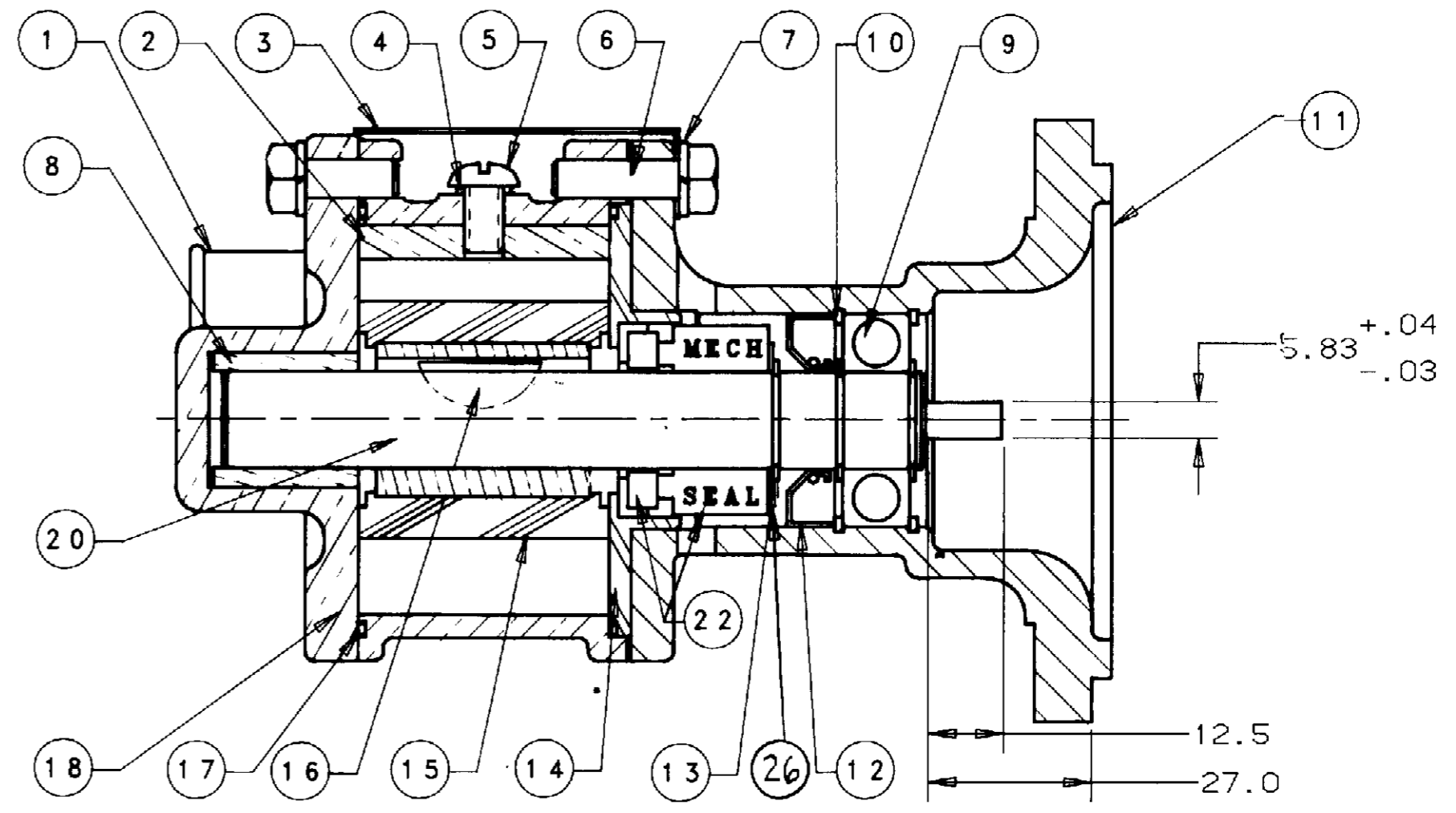

REV	DESCRIPTION	APPR	DATE

UNLESS OTHERWISE SPECIFIED
 CAST DIMENSIONS ± .02
 FILLETS & RADII .06
 FINISH STOCK .07
 MACHINING TOLERANCE, INCHES
 XX ± .01, XXX ± .005
 SURFACE ROUGHNESS $\sqrt{\quad}$
 ANGLES ± 0° 30'
 CORNER BREAKS .01 MAX.

□ FLATNESS .0015 IN/IN
 ⊥ SQUARENESS .0015
 ○ CONCENTRICITY .002
 ○ ROUNDNESS .0005
 ○ RUNOUT .002

SHERWOOD
 A DIVISION OF HYPRO CORPORATION
 6331 E. JEFFERSON AVE. • DETROIT, MICHIGAN 48207

DRAFTSMAN	DATE	CHECKER	DATE	ASSY NO.
TLG	8-1-95			

TITLE: **RUBBER IMPELLER PUMP**

MATERIAL: SEE DETAILS DWG. NO: G1006