

PARTS LIST				CATERPILLAR PART NO.
ITEM	DESCRIPTION	REQ'D	PART NO.	PART NO.
1	SHAFT	1	16045	7E0316
2	EXT. RET. RING	3	15952	4M7651
3	INT. RET. RING	1	15942	5F5078
4	BALL BEARING	2	15951	8H4320
5	END PLATE	1	16047	
6	END PLATE PIN	1	18442	
7	KEY	1	19209	
8	CAM	1	18271	7E0319
9	CAM SCREW	1	10515	7E0327
10	MECH. SEAL	1	15954	
11	SEAL SEAT	1	15953	
12	SPACER	1	15940	7E0345
13	HOUSING	1	18387	
14	FLAT WASHER	3	15959	7E0325
15	RUBBER IMPELLER	1	17000	7E0321
16	O-RING	1	15945	5P2931
17	5/16 LOCK WASHER	3	15944	9M1974
18	5/16 HEX. CAPSCREW	3	16029	8T9043
19	COVER PLATE	1	18625	7E0317
20	DRAIN PLUG HEX.	2	339	5B7890
21	SEAL & SEAT ASS'Y	SERVICE	15955	7E0322
22	PIN-END PLATE ASS'Y	SERVICE	18441	7E0328
23	MINOR SERVICE KIT		18284	
24	MAJOR SERVICE KIT		18285	
25	RUBBER CAP	1	19210	

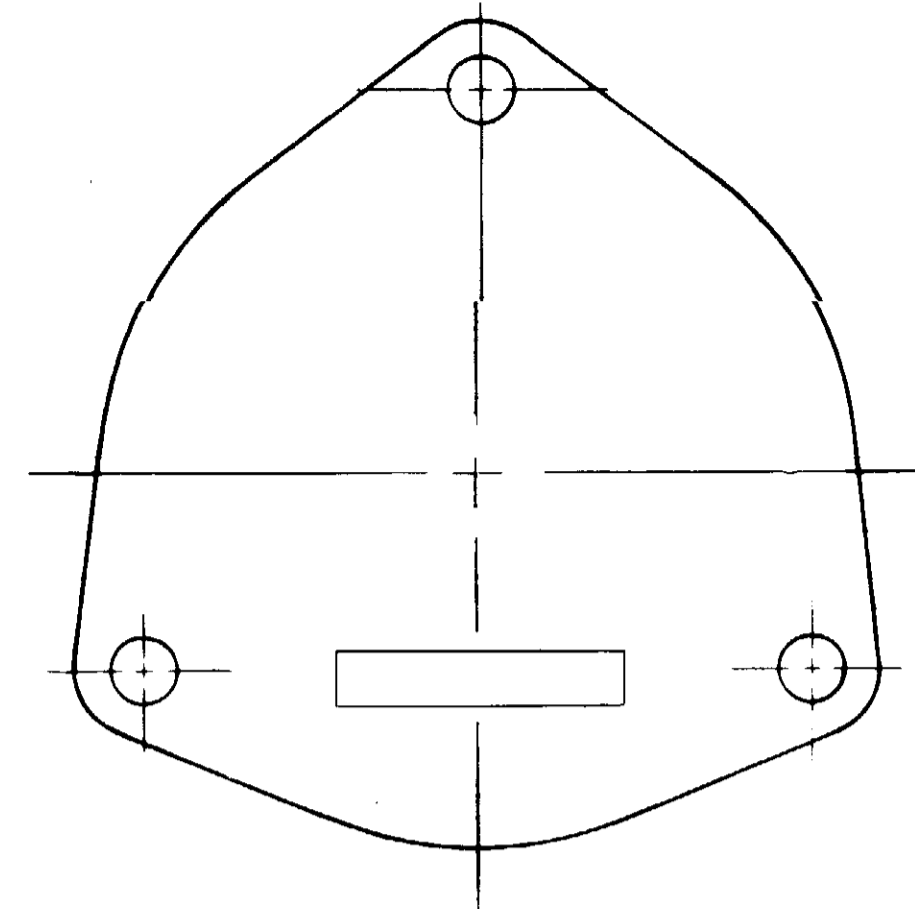

VIEW OF COVER PLATE

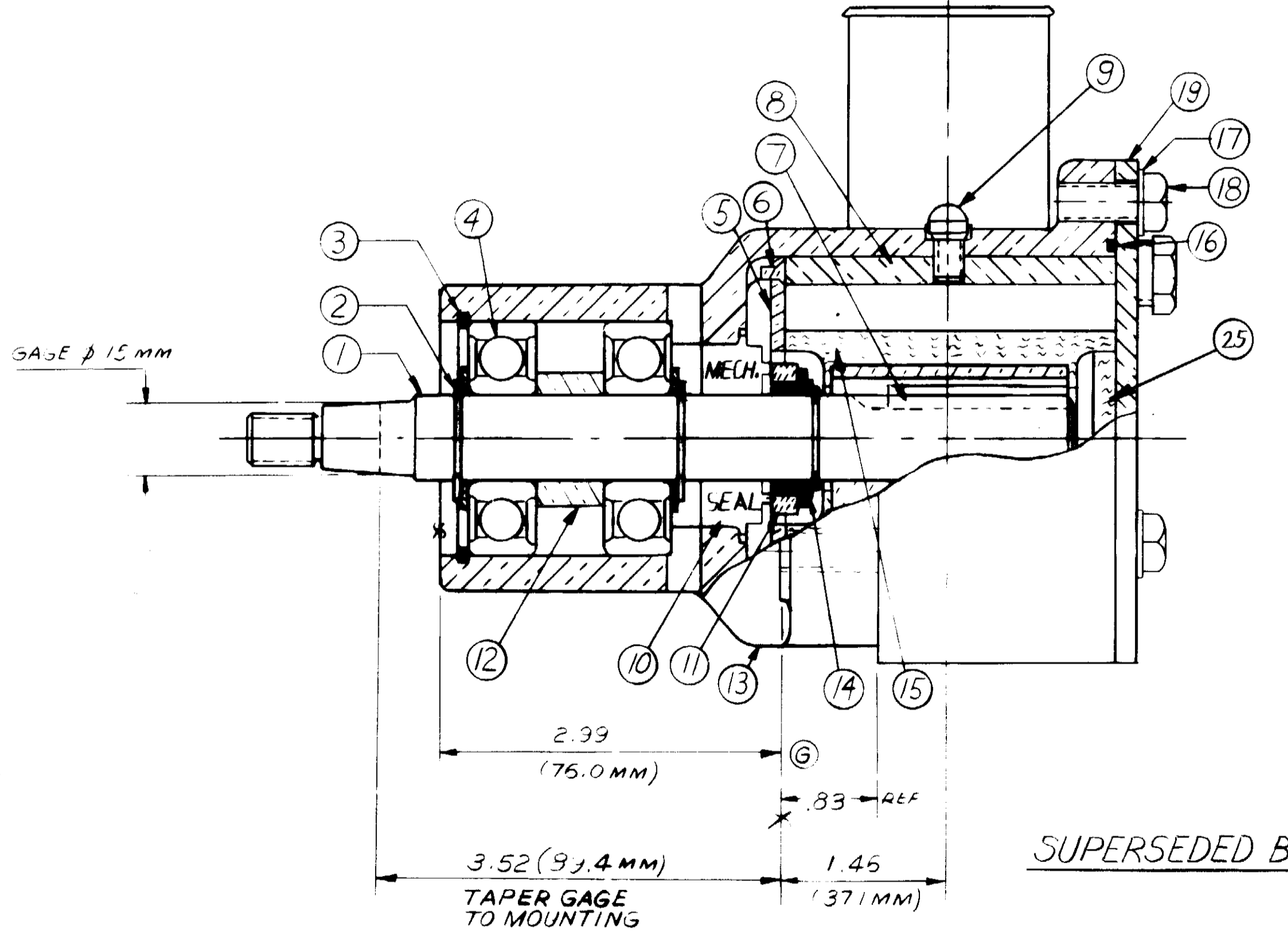
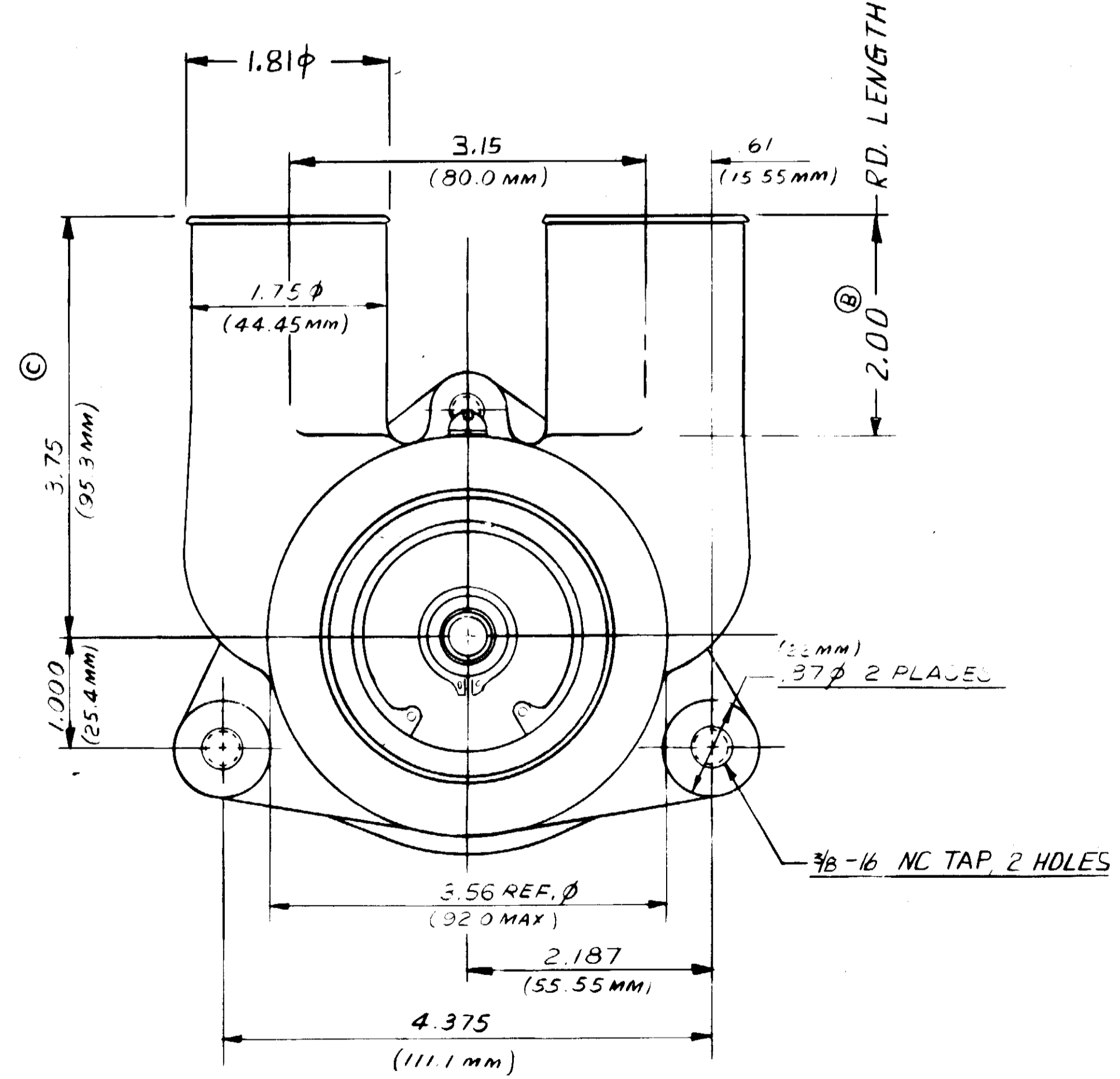
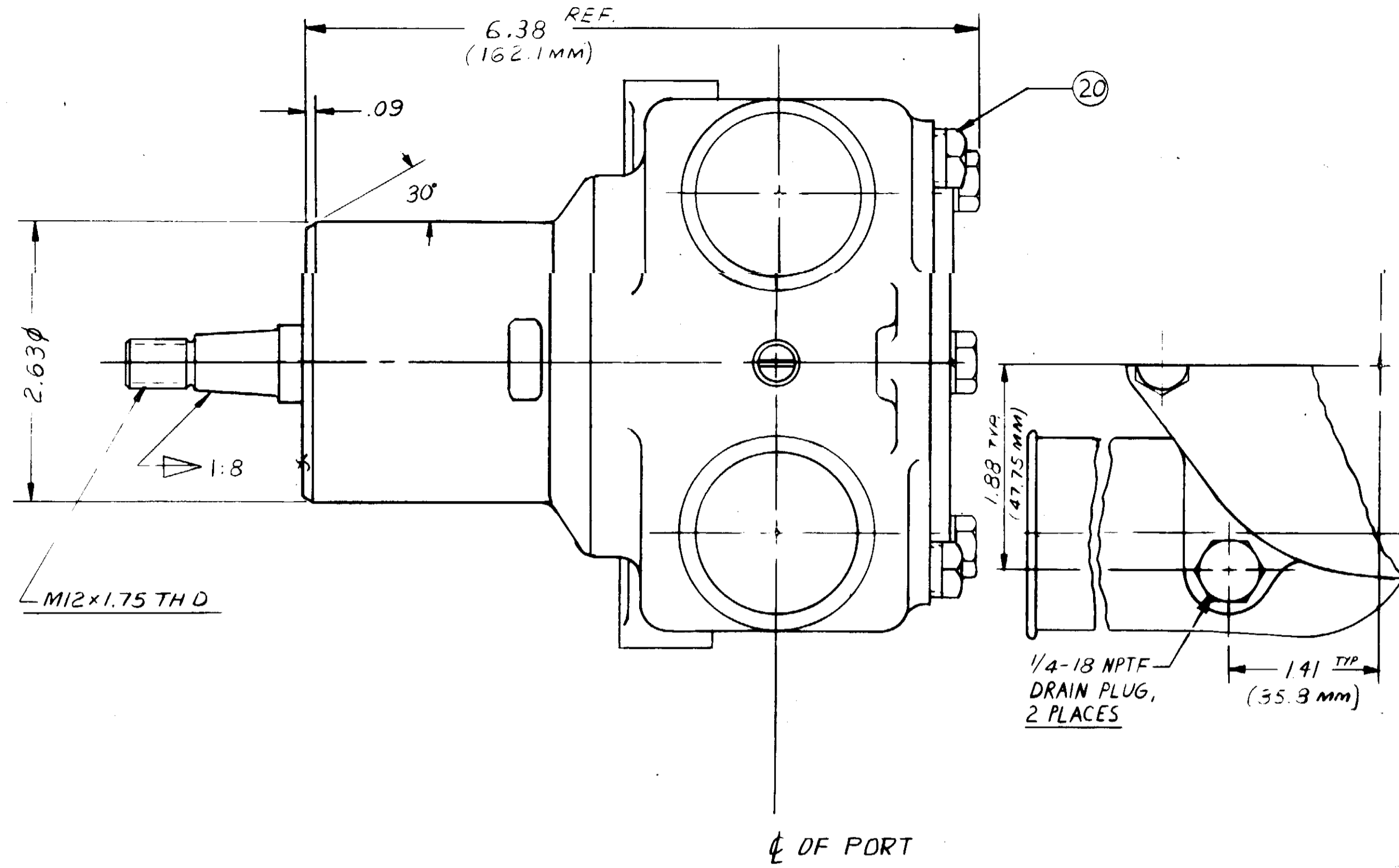

SUPERSEDED BY N° P176

REV	DESCRIPTION	APPR	DATE
J	19210 CAP ADDED	SH	7/26/88
I	19209 WAS 15948	SH	1/26/80
H	CATERPILLAR ASS'Y N89Y304 AND COMPONENT PART NO'S ADDED		
G	MOUNTING FLANGE RELOCATED	AVB	10/26/88
F	#18285 MAJOR SERVICE KIT ADDED	AVB	10/26/88
E	#18284 MINOR SERVICE KIT ADDED	AVB	10/26/88
D	18271 WAS 18488	ML	7/29/88
C	3.75 WAS 3.25	SH	7/5/88
B	2.00 WAS 1.50	SH	7/5/88
A	SHAFT-END TAPER WAS STRAIGHT	ML	2/24/88

UNLESS OTHERWISE SPECIFIED  
 CAST DIMENSIONS ± .02  
 FILLETS & RADII .06  
 FINISH STOCK .07  
 MACHINING TOLERANCE INCHES  
 XX ± .01, XXX ± .005  
 SURFACE ROUGHNESS  
 ANGLES ± 0° 30'  
 CORNER BREAKS 01 MAX  
 PARALLELISM .001  
 FLATNESS .001  
 SQUARENESS .001  
 CONCENTRICITY .001  
 ROUNDNESS .002  
 RUNOUT .001

**SHERWOOD**  
 A LEAR SIEGLER COMPANY  
 6331 E. JEFFERSON AVE. • DETROIT, MICHIGAN 48207

DRAFTSMAN: ML  
 DATE: 2-24-88  
 CHECKER: AVB  
 DATE: 2/24/88  
 PCSJ. NO.: 641-1

TITLE: RUBBER IMPELLER PUMP ASSY

MATERIAL: SEE DETAIL  
 DWG NO.: P171

CATERPILLAR # 9Y1304