

ITEM	DESCRIPTION	REQ'D	PART NO.	CATERPILLAR PART NO.
1	SHAFT	1	19620	
2	Nº 9Y3829 GEAR ASSEMBLED BY CATERPILLAR			
3	LIP SEAL	1	15950	7E0323
4	EXT. RET. RING	3	15952	4M7651
5	INT. RET. RING	1	15942	5F5053
6	FLANGE MOUNTING ADAPTER	1	15949	7E0320
7	BALL BEARING	2	15951	3H4320
8	END PLATE	1	16047	
9	END PLATE PIN	1	18442	
10	KEY	1	19209	4P5926
11	CAM	1	18693	7W9453
12	CAM SCREW	1	19673	6V9482
13	MECH. SEAL	1	15954	
14	SEAL SEAT	1	15953	
15	SPACER	1	15940	7E0345
16	HOUSING	1	18098	7E0318
17	FLAT WASHER	1	15959	7E0325
18	RUBBER IMPELLER	1	17000	7E0321
19	O RING	1	15945	372944
20	3/4 LOCK WASHER	3	15944	374224
21	3/4 HEX. CAP SCREW	3	16029	3L4509
22	FLAT WASHER	2	18171	7X0608
23	3/4 SOC. HD. BOLT	2	16030	2U5245
24	COVER PLATE	1	16048	7E0317
25	DRAIN PLUG, HEX.	2	339	5B7890
26	CARTON	1	17631	
27	LABEL	1	12209	
28	SEAL & SEAT ASSY	SERVICE	15955	7E0322
29	PIN-COVER PLATE ASSY	SERVICE	18441	7E0323
30	MINOR SERVICE KIT	ITEMS 10, 12, 23	18284	
31	MAJOR SERVICE KIT	ITEMS 4, 7, 18, 19, 21, 28, 29	18285	
32	RUBBER CAP	1	19210	4P5927
33	VAPOR PAPER	1	19565	
34	FLAT WASHER	2	19614	

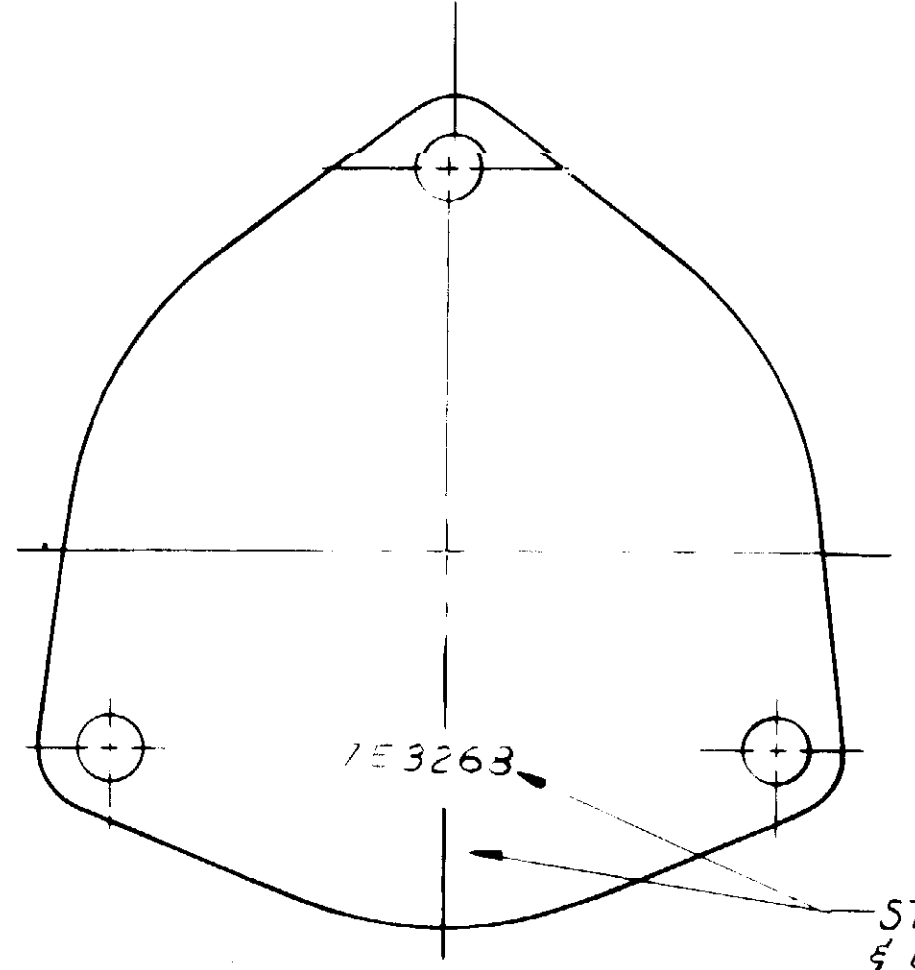

VIEW OF COVER PLATE
STAMP ASS'Y NO. & DATE CODE

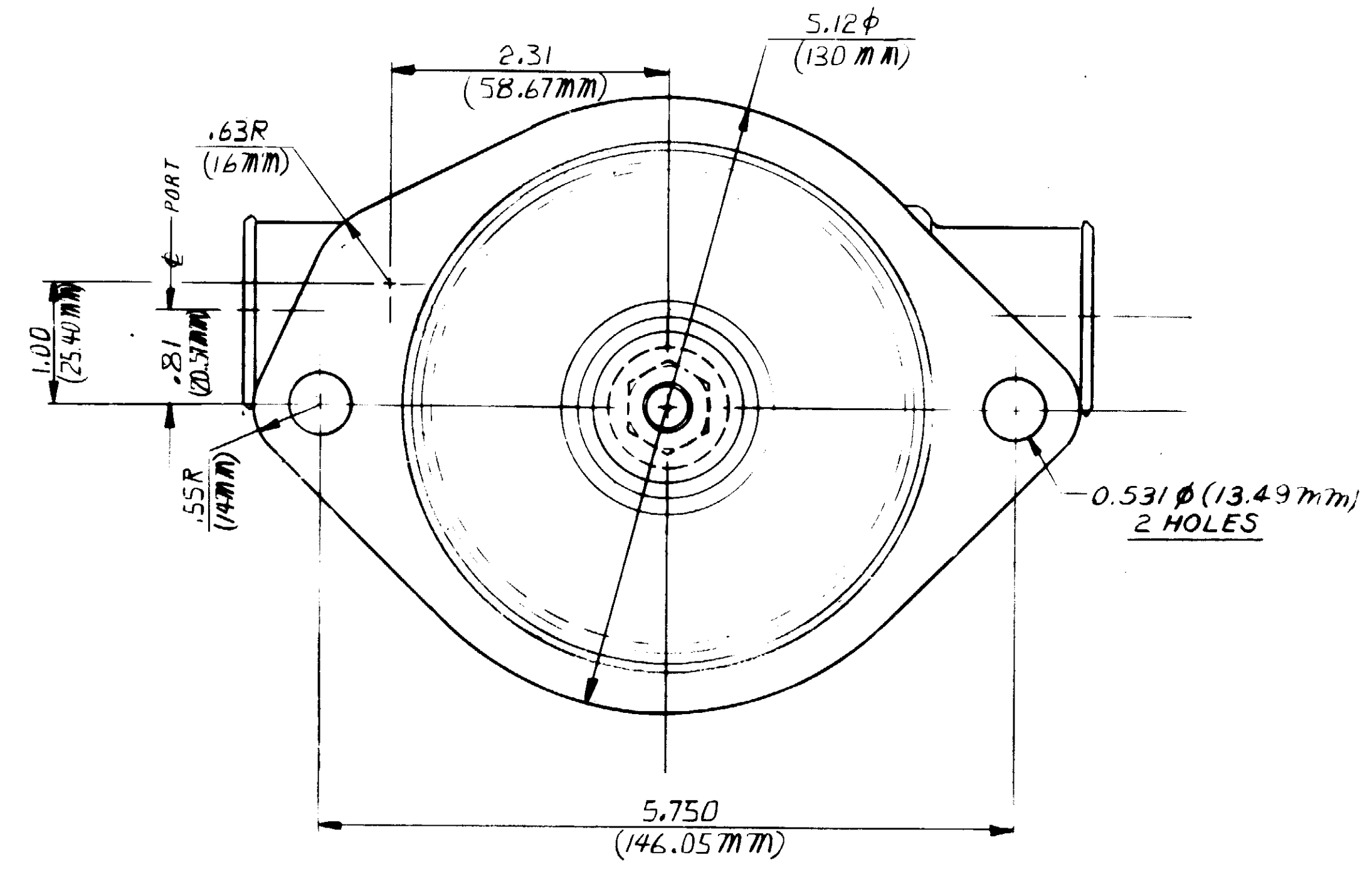
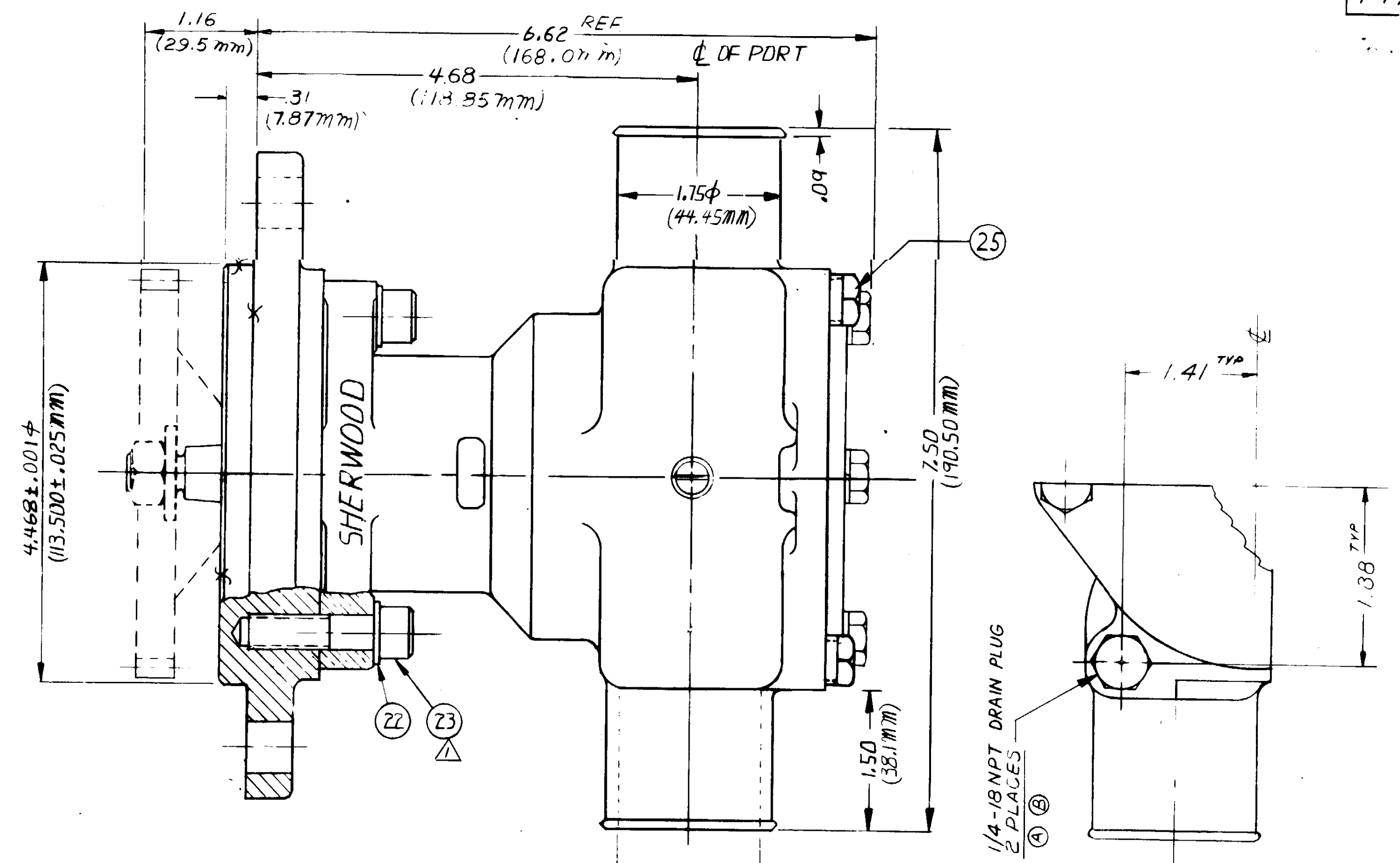

NOTE: WRAP ASSEMBLED PUMP WITH Nº 19565 (ONE SHEET) VAPOR PAPER BEFORE PACKAGING.

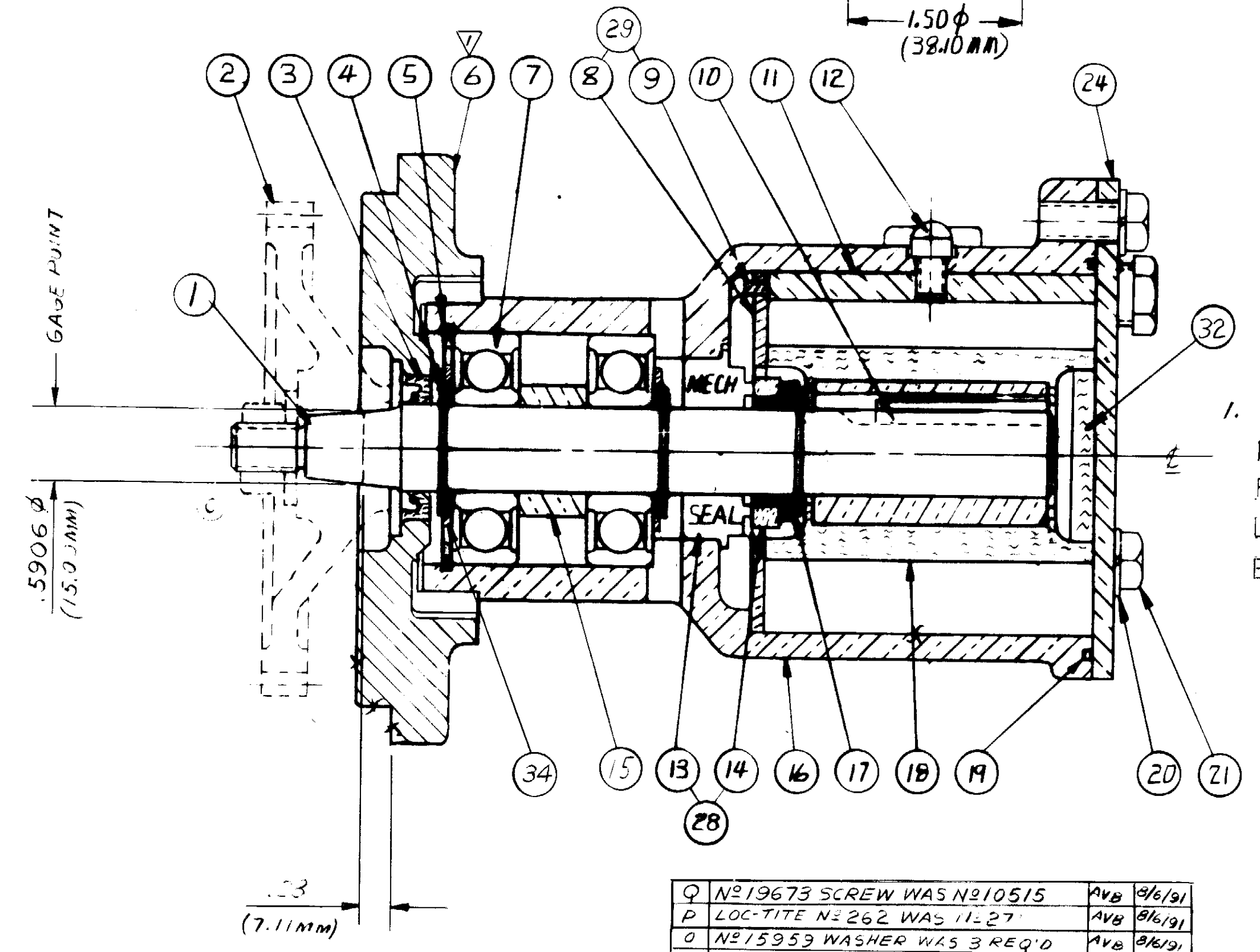

NOTE: DEGREASE BOLTS PRIOR TO INSTALLATION, USE LOCTITE PRIMER # 25556 FOLLOWED BY LOCTITE # 262 TORQUE 3/8" BOLTS TO 18 LB-FT

REV	DESCRIPTION	APP'D	DATE
Q	Nº 19673 SCREW WAS Nº 10515	AVB	8/6/91
P	LOC-TITE Nº 262 WAS 11-27	AVB	8/6/91
O	Nº 15959 WASHER WAS 3 REQ'D	AVB	8/6/91
N	Nº 19614 FLAT WASHER ADDED	AVB	8/6/91
M	SHAFT WAS Nº 16045	KB	7-1-91
L	ITEM 33 ADDED	KB	3-21-91
K	LOCTITE WAS Nº 271	KB	2-5-91
J	19210 ADDED	SH	7/26/90
I	19209 WAS 15948	SH	7/26/90
H	TOLERANCE CHANGED	BAW	5/22/88
G	CATERPILLAR ASS'Y Nº 7E3268 ADDED	AVB	2/12/88
F	MODEL Nº P172 WAS Nº P01	AVB	2/12/88
E	MAJOR REPAIR KIT REVISED	AVB	2/5/88
D	MINOR REPAIR KIT REVISED	AVB	2/5/88
C	SHAFT-END REVERSE TO TRANSMISSION DRIVE	AVB	2/5/88
B	WAS 1/8-27 NPT TO 1/4-18 NPT	AVB	2/5/88
A	WAS 1/4-18 NPT	KB	2-18-88

UNLESS OTHERWISE SPECIFIED
CAST DIMENSIONS ± .02
FILLETS & RADIUS .06
FINISH STOCK .07
MACHINING TOLERANCE, INCHES
XX ± .01, XXX ± .005
SURFACE ROUGHNESS
ANGLES ± 0° 30'

SHERWOOD
A DIVISION OF HYPRO CORPORATION
6331 E. JEFFERSON AVE., DETROIT, MICHIGAN 48224

DRAFTSMAN: ML DATE: 3/23/88 CHECKER: AVB DATE: 3/25/88 TITLE: RUBBER IMPELLER PUMP ASSY

MATERIAL: SEE DETAILS