

CP-20 and CP-30 Centrifugal Circulator Pumps Installation, Operation, and Maintenance

The Concept: CP-20 and CP-30 are centrifugal pumps designed for use in fresh or salt water (hot or cold) circulating systems. Construction is of bronze, stainless steel, or is non-metallic, so these pumps may be used to pump nearly any non flammable, non-explosive liquid.

Installation: Install the pump in a location that will provide generous air flow to aid in motor cooling. Fasten securely to the mount platform with four (4) 1/4" stainless steel fasteners.

Pumps are not self-priming; the installation location must assure a flooded inlet.

Bonding: GROCO pumps must be connected to the vessel bonding system. Use 14-gauge (or larger) stranded copper wire and a ring terminal beneath one of the bolts that holds the pump castings together to make this connection.

Warning: Motorized equipment must have a separate connection to the vessel DC grounding bus in accordance with ABYC, E-11, Figure-18. DO NOT make pump bonding connection in series with non-motorized equipment such as strainers or seacocks.

Electrical: Proper wire size is essential for proper motor and pump performance. Refer to the wire size selection chart enclosed. The orange wire is positive (+). Make electrical connections with marine grade crimp terminals.

Operation: Consider controlling CP-20 or CP-30 with GROCO Pump Cycle Timer PC-10 or FPC-10.

Maintenance: No regular maintenance is required.

Winterization: Freezing water within will damage the pump. Close the inlet seacock and disconnect the connecting fittings or hose to drain water. Remove the pump cover to drain water from the pump cavity.

Plumbing: Make plumbing connections with pipe, hose, or pipe-to-hose adaptors. Double clamp hose connections and use TFE thread tape on pipe connections.

Avoid sharp bends and sags in plumbing lines, and use full-flow fittings and hose if possible.

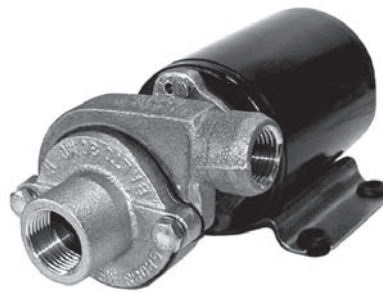

CP-20 has 3/4" NPT Inlet, Outlet is for Garden Hose or 1/2" NPT



CP-30 has replaceable motor brushes. Inlet and Outlet are the same as CP-20

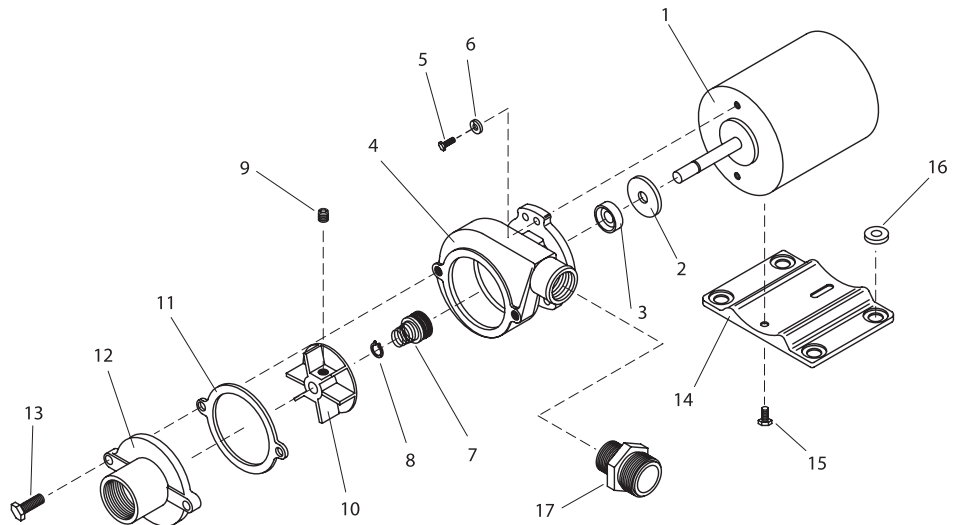

Item	Part Number	Part Name	Qty	Service Kit
1	(voltage)-B	Motor (CP-20 Series)	1	
	(voltage)-M	Motor (CP-30 Series)	1	
NS	24137901	Brushes (M series)	1	
2	SP-95	Washer	1	
3	031-075-8	Seal	1	*
4	CP-20-A	Housing	1	
5	1032X12HS	Screw	2	
6	10SS	Lockwasher	2	
7	69026	Seal Assy	1	*
8	Snap Ring-1	Snap Ring	1	*
9	14X14SET	Set Screw	1	
10	CP-55	Impeller & Set Screw	1	
11	CP-56	Gasket	1	*
12	CP-58-H	Cover	1	
13	1420X34HS	Screw	2	
14	B-200-P	Base	1	
15	1032X12HST	Screw	2	
16	B-200-G	Grommet Set (4)	1	
17	GHM500M	1/2 NPT x GH Adaptor	1	
	P-2			*