

- Parts modules and code #:
- ①+②: Front casing unit (CCW) code #MD0027
  - ⑩+②: Front casing unit (CW) code #2240075700
  - ③+⑨: Rear casing unit (CCW&CW) code #MD0038
  - ⑤: O-ring FKM(CCW&CW) code #0322500009
  - ⑥+⑧: Impeller unit (CCW) code #2240076800
  - ⑦+⑧: Impeller unit (CW) code #2240076900
  - ⑪+⑫+⑭: Drive magnet unit (CCW&CW) code #MD0615
  - ⑬: Motor code #1000580900

SPECIFICATIONS		
FREQUENCY (Hz)		50/60
MAX. CAPACITY (l/min)		1.8/2.0 x 2
MAX. HEAD (m)		1.7/2.2/2.3
VOLTAGE (V)		220/240
MOTOR OUTPUT (W)		20
PHASE (φ)		1
COATING MUNSSELL NO		2.5BG4.5/6

NO	PARTS NAME	QTY	MATERIAL	REMARKS
1	FRONT CASING	1	GFRPP	
2	BEARING	4	RULON PTFE	
3	REAR CASING	2	GFRPP	
5	O RING	2	EPDM	ARP568-037
6	IMPELLER	1	GFRPP	
8	SPINDLE	2	ALUMINA CERAMICS	
9	THRUST RING	4	ALUMINA CERAMICS	
11	DRIVEN MAGNET	2	FERRITE	
12	MAGNET HOUSING	2	ALUMINUM	
13	DRIVE MAGNET	2	FERRITE	
14	HEX SOCKET SET SCREW	2	STEEL	M4x6
15	MACHINE SCREW	12	STNLS STL	M4x32 WITH SW,PW
16	FRONT CASING CW	1	GFRPP	
17	IMPELLER CW	1	GFRPP	
18	MOTOR	1		
108	CAP	2	PE	

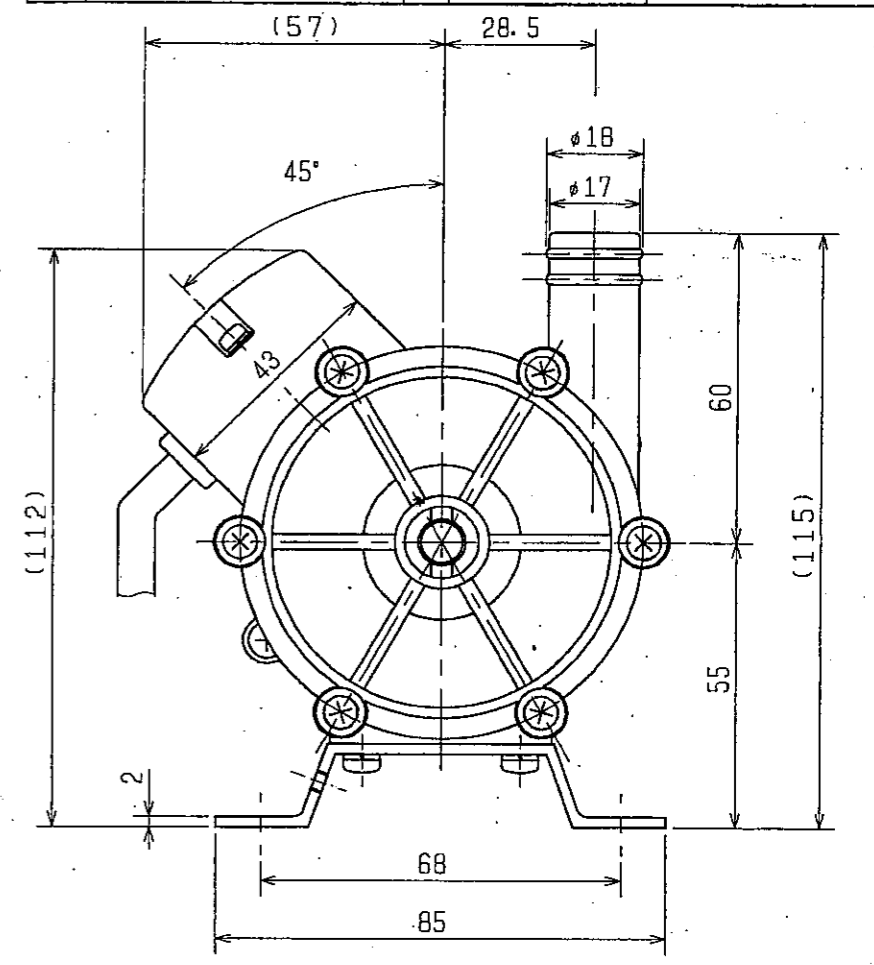
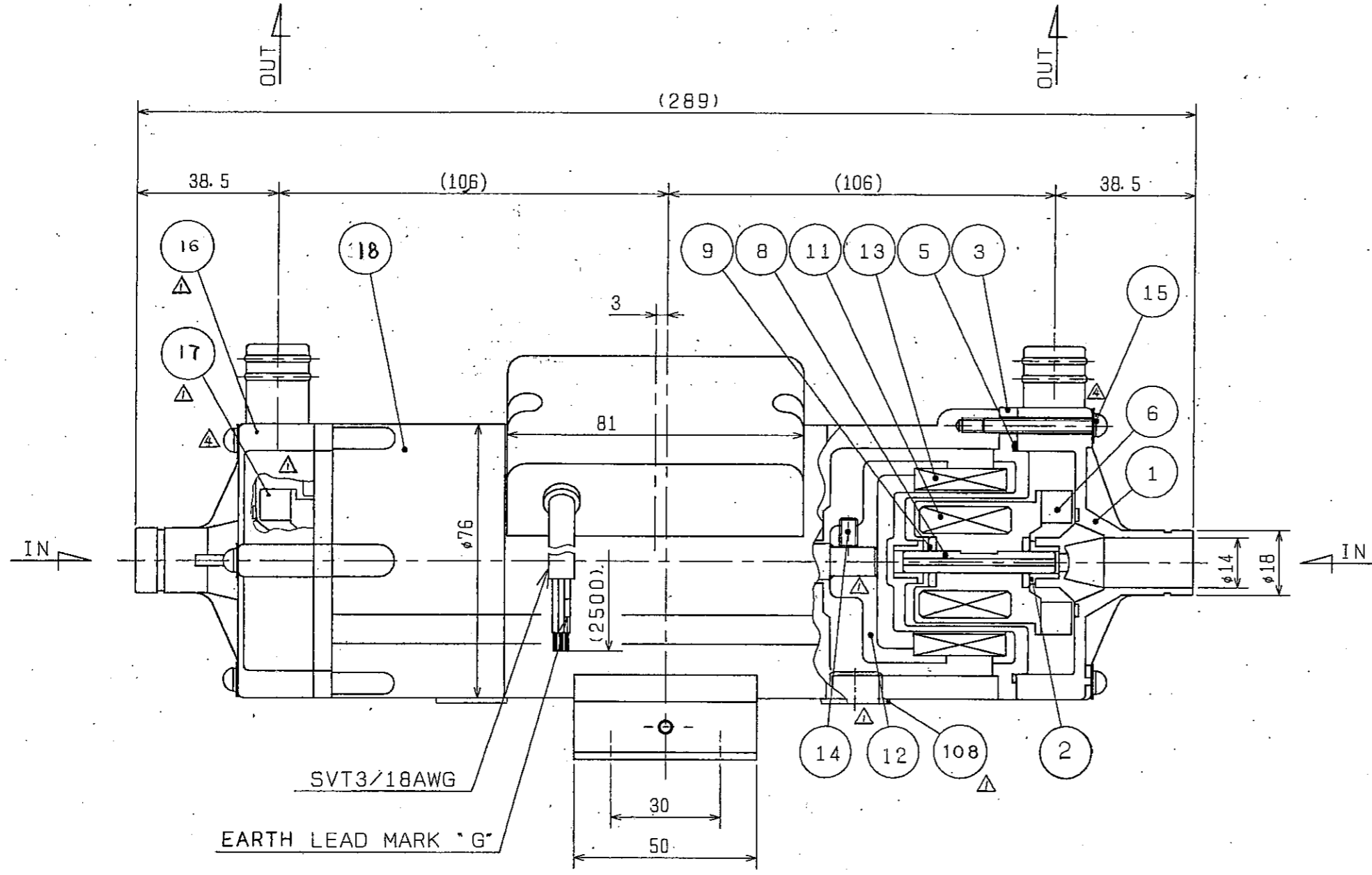

02-12-19:13:47 ; 17キ 技術 ; 81-0429691616=ABC # 2 / 2

マーク	改訂事項	改訂 NO.	日付	担当
MARK	REVISION	REV. No.	DATE	NAME
△	Correction	MD-1448	FEB. 7, 1995	Y. Kurihara
△	Correction	MD-1319	AUG. 25, 1993	Y. Kurihara
△	Correction	MD-1263	JAN. 14, 1993	Y. Kurihara
△	Correction		AUG. 12, 1992	Y. Kurihara

承認 APPROVED BY 21. Ohnishi	検 査 CHECKED BY K. Ohtsuka	設計製図 DRAWN BY Y. Kurihara	重量 WEIGHT 2.3 kgf	名称 IWAKI MAGNET PUMP
単位 UNIT : mm 1/16INCH			TITLE CONSTRUCTION DRAWING	
尺度 SCALE NTS			型式 2MD-15R-220ENUO2	
コード CODE No.			MODEL 2MD-15R-220ENUO1	
MAY. 9, 1991			図 番 DWG No. 2A35684	