



***IWAKI WALCHEM  
MAGNETIC DRIVE PUMP  
SMD SERIES  
INSTRUCTION MANUAL***

# SMD SERIES INSTRUCTION MANUAL

## Table of Contents

1	Unpacking and Inspection .....	1
2	Model Identification Guide .....	1
3	Specifications .....	2
	Materials of Main Components .....	3
	Description on Main Unit Body and Labels .....	4
4	Handling Instructions .....	5
5	Installation, Piping, and Wiring .....	8
	Installation Position .....	8
	Foundation Preparation .....	8
	Lifting .....	8
	Piping .....	9
	Suction Piping .....	10
	Discharge Piping .....	11
	Wiring .....	12
6	Operation .....	13
	Notes on Operation .....	13
	Start-Up Preparation .....	13
	Starting Operation .....	14
	Stopping Operation .....	15
7	Maintenance and Inspection .....	15
	Daily Inspection .....	15
	Periodic Inspection .....	16
	Wear Limits of Spindle, Bearing, Mouth Ring & Impeller Thrust .....	17
	Wear Checking Steps .....	18
8	Troubleshooting .....	20
9	Parts Description and Exploded View .....	22
10	Disassembly and Assembly .....	23
11	Spare Parts .....	25
12	Weights and Dimensions .....	26

Thank you for selecting an Iwaki Walchem SMD Series magnetic drive pump. This instruction manual explains the correct handling, maintenance, inspection and troubleshooting procedures for your pump. Please read through it carefully to ensure the optimum performance, safety, and long service of your pump.

## 1 Unpacking and Inspection

Open the package and check that the product conforms to your order. Also, check each of the following points. For any problem or inconsistency, contact your distributor at once.

1. Check that the model number and the HP indicated on the nameplate conform to the specifications of your order.
2. Check that all the accessories you ordered are included.
3. Check that the pump body and parts have not been accidentally damaged or that any bolts or nuts have not been loosened in transit.

MODEL SMD			
HEAD (FT.)			
CAPACITY (GPM)			
HP	60 Hz.		RPM
SERIAL NO.			
HOLLISTON, MA 01746			

## 2 Model Identification Guide

1
2
3
4
5  
SMD - 401 CV 6 - D

1	<b>Casing Material</b>	Glass fiber reinforced polypropylene (GFRPP)	
2	<b>Discharge Port Diameter Motor Output</b>	<b>401:</b> 1 1/2" x 1 1/2" flanged 1.5 HP Max	
3	<b>Materials of Construction Bearing Spindle O-Ring*</b>	<b>CV</b> Carbon Alumina Ceramic FKM	<b>FV</b> Carbon High purity Alumina Ceramic FKM
4	<b>Impeller Code</b>	<b>6:</b> 60 Hz	
5	<b>Construction Code**</b>	<b>D:</b> Pin-Point contacting bearing system	

\* Alternate o-ring materials are also available

\*\* Models ending in "DF" designates the addition of a flywheel to the drive magnet

### 3 Specifications

---

<b>Model</b>	SMD-401
<b>Port Connection (IN) Suction x Discharge</b>	1 ½ x 1 ½ flanged
<b>Standard Performance 60 Hz (GPM @ FT)</b>	53 @ 26
<b>Rated Speed (RPM)</b>	3450
<b>Motor Output (HP)</b>	1 or 1.5
<b>Self Priming Limit Height (FT)</b>	13 (Water @ 68°F)

Notes:

1. Rated performance (head/capacity) represents the maximum discharge head/capacity measured with water at 70°F (21°C).
2. Liquid temperature range: 32 - 176°F (0 - 80°C)  
Ambient temperature range: 32 - 104°F (0 - 40°C)
3. Slurry: Standard pumps are not suitable for slurry applications. Contact Iwaki Walchem or your distributor for details.
4. Specific gravity capability at maximum flow with maximum impeller when fluid viscosity is 1cp. Specific gravity fluids up to 1.2 can be handled with no trimming of the impeller.
5. The SMD-401, when coupled to a 1½ HP motor should use a flywheel drive magnet assembly, part number MFL1361, when operated at voltages exceeding the nominal rating of 460V. The addition of this flywheel drive magnet will prevent decoupling.

Note that the SMD-401 with a 1 HP motor does NOT require the flywheel drive magnet.

■ **Materials of Main Components**

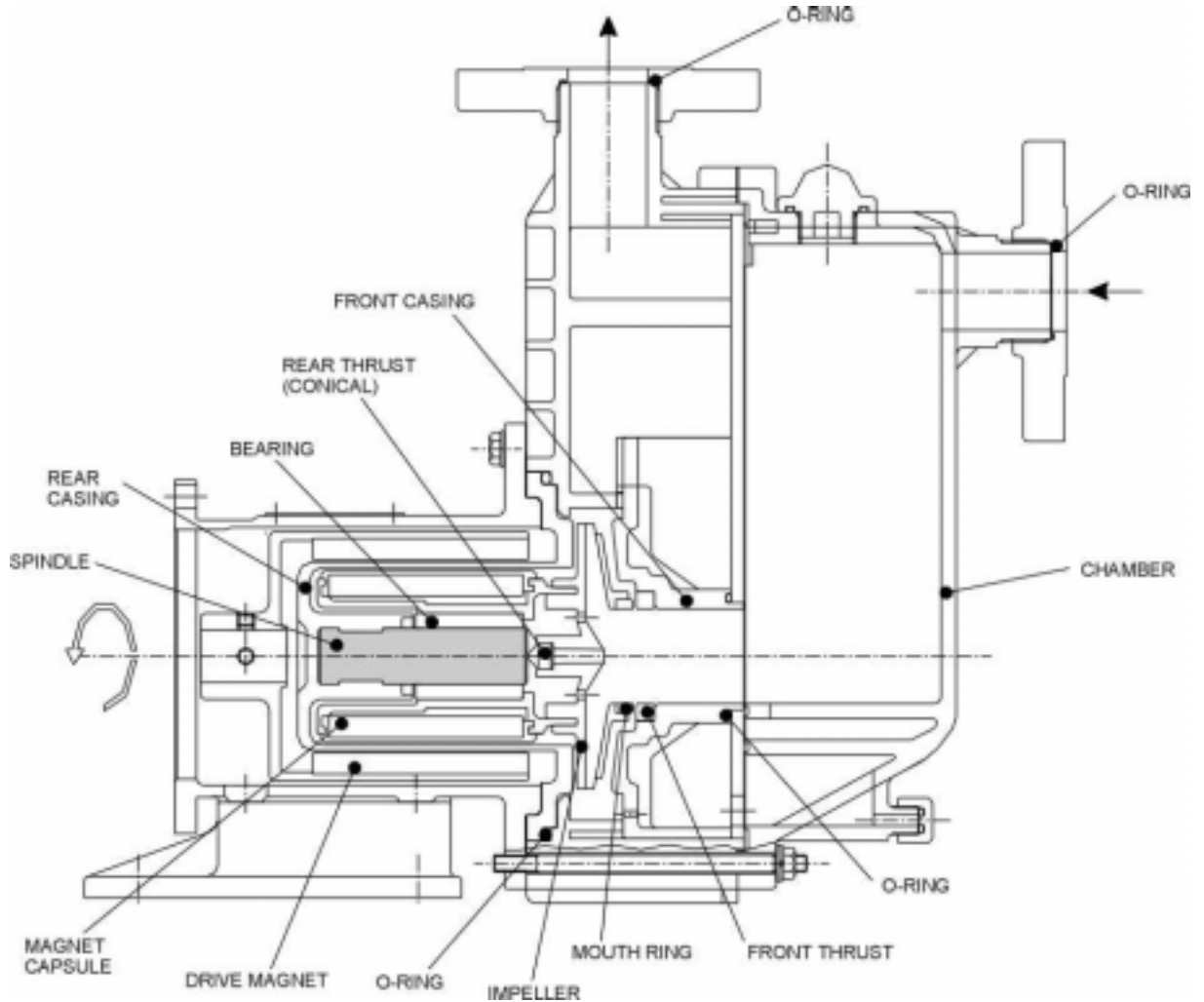

PARTS	SMD-401	
	CV	FV
Chamber	GFRPP (Glass fiber filled polypropylene)	
Casings & Impeller		
O-Ring	FKM (Viton) (EPDM optional)	
Spindle	Alumina ceramic	99.8% Alumina cermaic
Bearing	Carbon	
Mouth ring	PTFE	
Front thrust ring	Alumina ceramic	99.8% Alumina ceramic
Rear thrust	Carbon	
Magnet capsule	GFRPP (Glass fiber filled polypropylene)	
Drive magnet	Ferrite	

■ **Description on Main Unit Body and Labels**

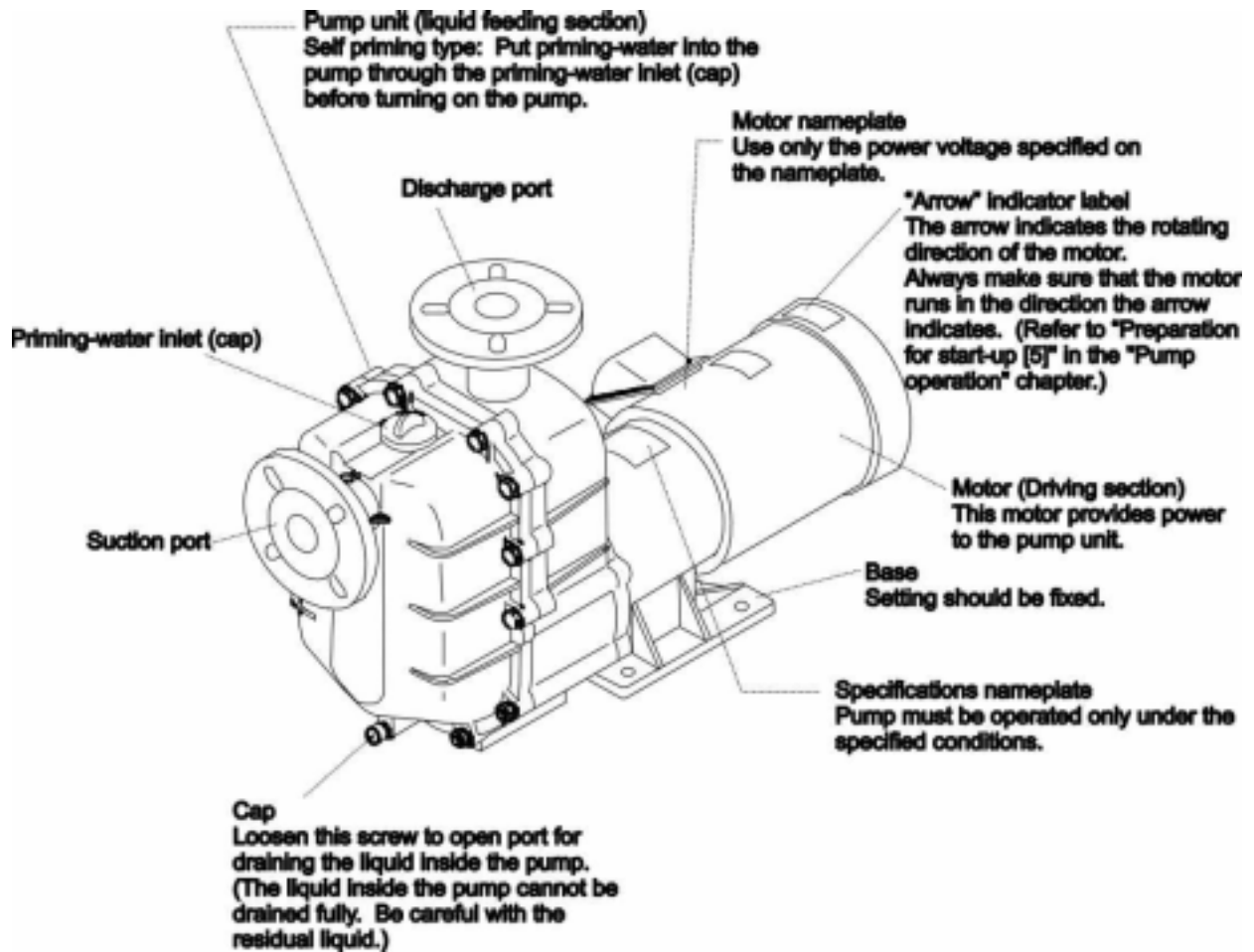

## 4 Handling Instructions

---

### 1. Dry run operation, unless using a “-D” model

Dry run operation of the pump may cause damage to the pump internally. The internal bushings used in the SMD series pump are lubricated and cooled by the fluid being pumped. If the pump is unavoidably or accidentally operated dry, with no obvious damage, allow the pump to cool down for a minimum of one hour before attempting to restart. Do not allow fluid to enter the pump cavity until the pump has cooled down. Sudden or rapid introduction of a cold fluid may cause damage to the bearing system. A dry run protection device is recommended for the prevention of damage when dry pump operation is anticipated.

#### “-D” Models

Most SMD models are designed to tolerate brief or intermittent dry run operation, they are identified by a "-D" at the end of the model number. These models can tolerate dry run conditions for up to one hour. Longer dry run periods, or frequent dry running may result in premature wear of the bearing surfaces. This can rapidly affect the standard clearances of the rotating elements inside the pump. These pumps are designed to reduce the likelihood of cracking resulting from sudden cooling with liquid immediately after dry run operation. However, to ensure that this does not occur, Iwaki Walchem recommends that the pump be allowed to cool for at least 20 minutes after dry running before introducing fluid again.

#### “-E” Models

Pumps identified with “E” at the end of the model identification cannot endure dry running operation.

### 2. Priming water

The pump is a self-priming type. However, it is necessary for the operator to feed priming water into the pump before initiating operation. Make sure to feed the priming water (or operation liquid) up to the specified level before operation. Otherwise the pump may seize or get worn excessively.

Model	Amount of Priming Water
SMD-401	1.75 Gallons

### 3. Starting and stopping the pump

Pay close attention to the following points to avoid water hammer action when starting and stopping pump operation. Extra attention is required if discharge-side piping is very long.

Starting and stopping the pump frequently will accelerate bearing wear. Starting/stopping in self-priming mode in particular should be limited to 1000 cycles.

- **Starting**

Prior to starting the pump, make sure that the power is turned OFF. Then carry out priming to fill the pump cavity with liquid (see Handling Instructions item #2). Close the cocks of any pressure or vacuum gauges to prevent damage from sudden pressure changes. Open only when taking measurements.

Next, open the valve on the discharge side. Now you can turn the power ON and start up the pump. Run the motor momentarily to check the direction of motor rotation. The motor should run in the direction indicated by the arrow sealed on the pump. If the direction is reversed, exchange two wires of the three-phase power wires.

- **Stopping**

When stopping the pump, first close the discharge valve gradually. When it is completely closed, turn off the power switch so that the pump stops. Never stop the pump suddenly by quickly closing a valve (i.e. solenoid or hydraulic valves).



**Caution!** Quick valve closure may cause water hammer which may result in severe damage to the pump.

**4. Maximum system pressure rating**

Be sure that the discharge pressure does not exceed the maximum pressure rating.

Temperature °F	Max Pressure Rating	
	PSI	Kgf/cm <sup>2</sup>
176	34	2.4

**5. Slurry liquids should not be handled.**

**6. Influence of specific gravity on pump performance**

The performance of the SMD pumps does not change when pumping fluids of high specific gravity. However, the effect of specific gravity on shaft power and magnet coupling torque requirements must be considered in the selection of the appropriate model for your application. Maximum specific gravity than can be handled is 1.2.

**7. Influence of liquid viscosity on pump performance**

When pumping a high viscosity liquid, the discharge head and capacity of the pump may be power than in the case of pure water. The required driving power may also vary and should be checked.



**8. Intermittent operation**

Frequent start/stop switching shortens the service life of the pump. Limit the frequency of switching to six times or less per hour.

**9. Effects of temperature**

Temperature fluctuation may not change the performance of the pump itself. However, the liquid may change in terms of viscosity, pressure or corrosive properties. Pay special attention to changes in liquid characteristics as a result of temperature fluctuation.

<b>Liquid temperature range</b> <b>Self priming capacity is lowered when liquid temp. is high.</b>	32-176°F (pure water) (0-80°C)
<b>Ambient temperature range</b> <b>Freezing is not permissible.</b>	32-104°F (0-40°C)
<b>Humidity range</b>	35-85% RH

Refer to the corrosion resistance table for the temperature ranges recommended for various types of liquid. For inquiries or consultation, contact Iwaki Walchem or your local distributor.

**10. Separation of magnet coupling (decoupling)**

If the magnet coupling should disconnect, stop the pump immediately. If operation is continued, the torque rate of the coupling will be permanently reduced.

## 5 Installation, Piping, and Wiring

---

### ■ *Installation Position*

1. Install the pump as close to the suction tank as possible. The installation position must be as low as possible, at a height within the self-priming limit that allows smooth pump performance. If the surface level of the suction tank varies, measure the height from the lowest surface level as the maximum self-priming height to confirm that it will not exceed the self-priming limit. For details, consult Iwaki Walchem or your distributor.
2. The pump can be installed indoors or outdoors. There should be sufficient space around the pump to enable efficient and easy maintenance. Safety measures should be taken not to expose the motor and power unit to flooding or other natural hazards.
3. Select an installation site that is flat and free of vibrations caused by nearby machines. There should be sufficient space for maintenance .

### ■ *Foundation preparation (before pump installation)*

1. The pump anchoring area must be greater than the area of the pump baseplate. If the anchoring area is not large enough, the baseplate may be damaged due to the concentration of loads placed on it.
2. Set the pump baseplate on a concrete foundation and fasten the anchor bolts tightly to prevent the pump from vibrating during operation. A sturdy metal (or reinforced) skid or platform is also an acceptable mounting surface.
3. In case of motor vibration during operation (e.g. sympathetic vibration with piping), an expansion joint should be provided between the pump and the piping before installation to prevent damage to pipes and gauges.

### ■ *Lifting*

When lifting the pump, please pay attention to the following points.

- Do not grab parts made of plastic (such as case, flange or base)
- The pump weighs approximately 55 lbs. It should be carried by two operators whenever possible.
- Always place the pump horizontally with its base down.

## ■ **Piping**

Suction lift method:

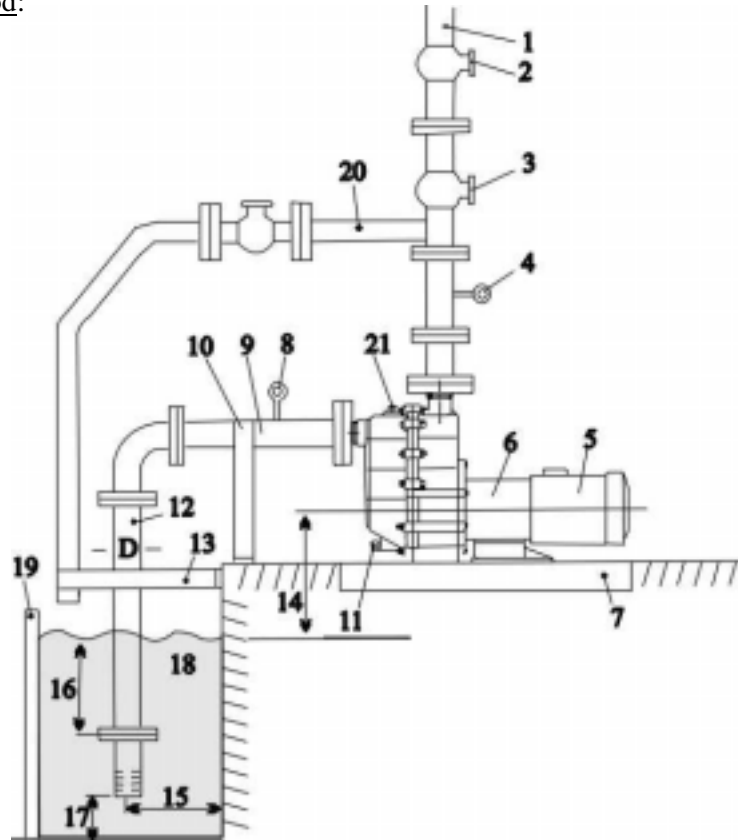

- |     |  |     |   |
|-----|--|-----|---|
| 1.  | Discharge pipe (support the pipe to keep pump free of piping load)   | 11. | Pump drain  |
| 2.  | Valve  | 12. | Suction pipe (pipe diameter: D)   |
| 3.  | Check valve  | 13. | Pipe support  |
| 4.  | Pressure gauge   | 14. | Self-priming height   |
| 5.  | Motor  | 15. | Larger than 1.5D  |
| 6.  | Pump   | 16. | 2D, 20" or above  |
| 7.  | Drain ditch  | 17. | 1 to 1.5 D or more (the distance must be more than 20" if sand or mud accumulates easily) |
| 8.  | Vacuum gauge   | 18. | Suction tank  |
| 9.  | Suction pipe (pipe diameter: D) (Horizontal section should be as short as possible & there should be an ascending gradient of 1/100 toward pump) | 19. | Filtering screen  |
| 10. | Pipe support   | 20. | Air bleeding pipe   |
|     |  | 21. | Priming water inlet (cap)   |

## ■ **Suction Piping**

1. The suction pipe can be used in either a suction lift or flooded suction condition. The shortest pipe possible, with the minimum number of bends, should be utilized. Arrange a proper support on the suction pipe so that the load and the thermal stress of the pipe itself are not applied to the pump.
2. Attach the coupling on the suction pipe carefully, so that no air enters the line. The presence of air in the suction pipe may prevent priming of the pump.
3. Avoid installations with poor suction conditions (e.g. vacuum in suction tank, large suction head or long suction piping). NPSHa should always be at least 2 feet greater than NPSHr. For NPSHr values, refer to the standard performance curve for your pump model or contact Iwaki Walchem or your distributor.
4. When using a bend on the suction side, install a straight pipe which is more than 20 inches long or 10 times as long as the suction port diameter before the suction port of the pump. Use the largest possible radius of curvature for the bend.
5. Do not allow any projection where air may be trapped along the suction pipe. The suction pipe should have an ascending gradient toward the pump.
6. If the diameters of the pump suction port and the suction pipe are different, use an eccentric reducer pipe. Connect the eccentric reducer pipe such that the upper part of it is level. **Never use a suction pipe with a diameter smaller than that of the suction port.**
7. When using the flooded suction method, the suction pipe should be given a slight ascending gradient toward the pump so that no air pocket is created on the suction side.
8. The end of the suction pipe should be located 18 inches or more below the surface of the liquid.
9. A screen should be provided at the inlet of the suction tank to prevent the entrance of foreign matter into the suction pipe. Foreign matter may cause malfunctioning of the pump. The end of the suction pipe should be at least 1- 1.5D from the bottom of the suction tank. (D=Diameter of suction pipe).
10. When employing the suction lift method, install a foot valve on the suction pipe.
11. When using the flooded suction method, it is recommended that a gate valve be installed on the suction pipe for easier overhaul inspection of the pump. Since this valve is used only in the overhaul inspection of the pump, keep it fully opened during normal pump operation.
12. Pay close attention to the lowest level of the liquid in the suction tank so that air entrapment to the suction piping will not occur.

The inflow pipe into the suction tank should be distanced from the suction pipe and positioned below the liquid surface as a means of preventing air entrapment to the suction pipe. If air bubbles are generated in the suction tank, install a baffle.

13. It is recommended that a vacuum/pressure gauge be installed on the suction piping approximately 6 pipe diameters from the pump suction port.

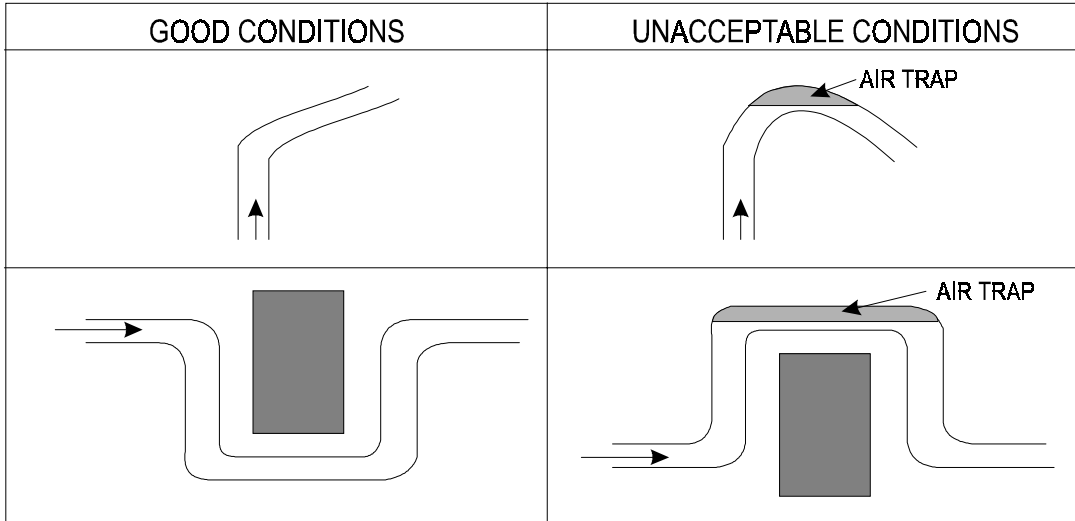

### ■ **Discharge Piping**

1. Use proper pipe supports so that the weight of the piping does not load the pump nozzle.
2. If a method other than flooded suction is used, install a special pipe for priming.
3. If the piping is very long, its diameter should be determined by calculating the piping resistance. Otherwise, the specified performance may not be obtained due to increased piping resistance.
4. A check valve should be installed if any of the following conditions exists in the piping:
  - The discharge piping is very long.
  - The discharge head is 50 feet or more.
  - The end of the discharge pipe is located 30 feet higher than the surface of the suction tank.
  - Several pumps are connected in parallel with the same piping.
5. The installation of a gate valve on the discharge pipe is recommended for the adjustment of discharge quantity and for the prevention of motor overload. When installing both a check valve and a gate valve, the check valve should be positioned between the pump and the gate valve.
6. A pressure gauge must be installed on the discharge piping.

7. An air bleeding valve should be installed if the discharge pipe is very long in the horizontal direction.
8. A drain valve should be installed for the drainage of liquid if there is a chance that the liquid in the discharge pipe will freeze.

## ■ Wiring

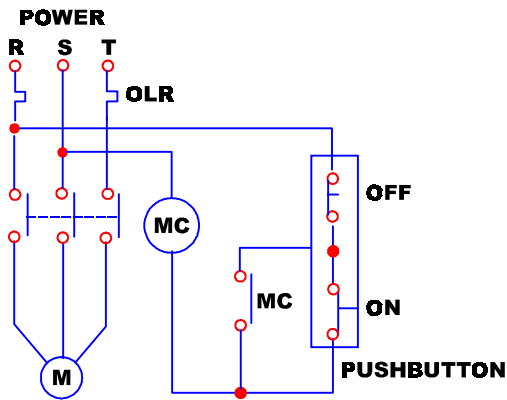

M	MOTOR
MC	MOTOR CONTACTOR
ON	PUSH BUTTON
OFF	
CLR	OVERLOAD RELAY

Use appropriate wiring materials, follow the instruction manual for the motor and abide by the local and national electrical codes. In addition, follow the instructions given below:

1. Use a motor contactor that conforms to the specifications (voltage, current, etc.) of the pump motor.
2. If the pump is installed outdoors, use waterproof wiring to protect the switches from rainwater and moisture.
3. The motor contactor and push button should be installed a reasonable distance from the pump.
4. Refer to the wiring example shown on the left. (This example does not include the installation of a dry-operation prevention device. Follow the instruction manual of the dry-operation prevention device when installing it.)

## 6 Operation

---

### ■ *Notes on Operation*

1. Never operate the pump with the suction-side valve (gate valve) closed. Otherwise, the internal bushings of the pump will be damaged.
2. In the event of cavitation, stop the pump immediately.
3. If the magnet coupling disconnects, stop the pump immediately. The torque rating of the magnet coupling will be reduced if operation is continued with the coupling disconnected.
4. Liquid temperature fluctuation should not exceed 176°F when starting, stopping, and operating the pump.
5. Be sure to close the discharge valve completely before starting operation in order to prevent water hammer upon start-up.
6. The pump should never be operated for a lengthy period with the discharge valve closed. The resulting rise in temperature of liquid in the pump may cause damage to the pump.
7. In the event of a service power failure, turn off the power switch immediately and close the discharge valve.

### ■ *Start-Up Preparation*

When operating the pump for the first time after installation, and when restarting operation after a long interval, prepare for operation as described below.

1. Thoroughly clean the inside of the piping and pump.
2. Tighten the union fittings or flange connecting bolts and baseplate installation bolts. Check that bolts which couple the front casing and the bracket together are securely fastened.
3. Open the priming inlet cap on the top section of the pump and put liquid into the pump. After the pump is filled, fasten the priming inlet cap tightly to prevent air leaks. Some types of liquid used as priming may corrode the metal parts of the pump. Be careful not to spill water over the inlet. If liquid is spilled, clean pump thoroughly.
4. In the flooded suction method, measure the pressure in the suction pipe to confirm that the pump is filled with liquid.

5. Run the motor momentarily to check the direction of motor rotation. The motor should run in the direction indicated by the arrow on the nameplate of the pump. If the direction is reversed, exchange any two wires of the three-phase power wires.

Note: All Iwaki Walchem SMD series pumps spin counter-clockwise when looking at the suction port of the pump. Naturally, from the motor fan side, this would be viewed as clockwise.

### ■ **Starting Operation**

Pump operation is detailed below.

Step	Check operation	Remarks
1	Verify valve position.	Suction valve fully open. Discharge valve fully closed.
2	Check that the pump is filled with liquid.	If pump is not filled with liquid, fill it in accordance with steps 3-4 of 'Start-up Preparation'.
3	Turn ON motor switch momentarily and check for correct direction of pump operation.	See the arrow on the casing to confirm the direction of rotation (clockwise when viewed from the motor fan side).
4	Turn on power and start pump. Then adjust the discharge pressure and discharge volume. <ul style="list-style-type: none"> <li>▪ For suction lift method: Open the discharge valve fully. Start the pump and make sure the air is discharged. With the pump in a normal operating condition, close the discharge valve gradually to obtain the specified discharge pressure level. It takes approx. 3 minutes with pure water at room temp. to discharge the air out of the pump and the suction pipe completely.</li> <li>▪ For flooded suction method: If the pump operates normally &amp; the pressure gauge on the discharge side indicates the pressure at the maximum level, open the discharge valve gradually to obtain the specified discharge pressure level.</li> <li>▪ Open/close the discharge valve gradually within one minute and adjust the discharge pressure while checking the pressure gauge on the discharge side. (Or adjust the flow rate on the discharge side while checking the flow meter.)</li> </ul>	
5	Points to be observed during operation. If pump enters continuous operation condition, check flow meter and confirm that pump operation meets specifications.	If flow meter is unavailable, check values of discharge pressure, suction pressure and current in relation to piping resistance.



■ **Stopping Operation**

Step	Check operation	Remarks
1	Close discharge valve gradually.	 <b>Caution!</b> Do not cause sudden closure by using solenoid valve, etc. Otherwise, pump may be damaged by water hammer.
2	Stop motor.	Observe that the motor stops rotating slowly and smoothly. If not, check inside of pump.
3	Points to be observed when stopping pump. If pump operation is stopped in cold weather, liquid inside the pump cavity may freeze and damage the pump. Be sure to drain liquid completely. In case of short-term shut down, which does not allow removal of liquid, use band heater, etc., to prevent liquid from freezing.  In case of service power failure turn OFF power switch and close discharge valve.	

## 7 Maintenance and Inspection

---

■ **Daily Inspection**

1. Check that the pump operates smoothly, without generating abnormal sounds or vibration.
2. Check the level of the liquid in the suction tank, and the suction pressure.
3. Compare the discharge pressure and current measured during operation with the specifications indicated on the motor and pump nameplates to verify normal pump load.

\* Note that the indicated value of the pressure gauge varies in proportion to the specific gravity of the liquid.



**Caution!** The valve of the pressure gauge or vacuum gauge should be opened only when measurements are recorded. It must be closed after completion of each measurement. If the valve remains open during operation, the gauge mechanism may be affected by abnormal pressure caused by water hammer.

4. If a spare pump is included in the installation, keep it ready for use by operating it from time to time.

■ **Periodic Inspection**

To ensure efficient, smooth operation of the pump, carry out periodic inspection by following the procedure described below. When carrying out an overhaul inspection, handle the internal bushings and plastic components most carefully. Since the outer drive magnet and inner magnet capsule are very powerful, handle these components with caution. Take care not to trap hands and fingers between the magnets and metal objects. Also avoid positioning the magnets near any electronic device (or ATM cards with magnetic strips) that could be affected by a strong magnetic field.

1. After thorough decontamination of the pump, remove liquid end assembly from motor bracket.
2. Remove front casing from the liquid end.
3. Insert magnet capsule with impeller into rear casing.
4. Measure clearance between backside of impeller shroud and face of rear casing, dimension "A" shown on pages 17 and 18.

Inspection Interval	Part	Inspection Points	Operator Action
Every 6 months *Inspection record should be maintained.	Drive magnet assembly	<ul style="list-style-type: none"> <li>▪ Is there scoring?</li> <li>▪ Is magnet mounted normally? Are hexagonal socket set screws loose?</li> <li>▪ Are inner perimeter of magnet &amp; motor shaft concentric?</li> </ul>	<ul style="list-style-type: none"> <li>▪ Contact your distributor if any abnormality is observed.</li> <li>▪ Re-install magnet on motor shaft and fasten hexagonal socket set screws.</li> <li>▪ Re-tighten or replace hexagonal socket set screws.</li> </ul>
Every 3 months *Inspection record should be maintained.	Rear casing	<ul style="list-style-type: none"> <li>▪ Is there scoring on the inner diameter?</li> <li>▪ Are there any cracks in liquid-containing section?</li> <li>▪ Stain in rear casing?</li> </ul>	<ul style="list-style-type: none"> <li>▪ Contact your distributor if any abnormality is observed.</li> <li>▪ Replace if abnormality is observed.</li> <li>▪ Clean.</li> </ul>
	Magnet capsule	<ul style="list-style-type: none"> <li>▪ Is there scoring in rear face or cylindrical body?</li> <li>▪ Are there any cracks in the plastic of the rear section or cylindrical body?</li> <li>▪ Bearing wear.</li> </ul>	<ul style="list-style-type: none"> <li>▪ Contact your distributor if any abnormality is observed.</li> <li>▪ Contact your distributor if any abnormality is observed.</li> <li>▪ Replace if any abnormality is observed. See tolerance chart.</li> </ul>

Every 3 months *Inspection record should be maintained	Impeller	<ul style="list-style-type: none"> <li>▪ Are there any cracks?</li> <li>▪ Are there any cavitation marks?</li> <li>▪ Stain or clogging inside impeller</li> <li>▪ Dimensional change of impeller</li> <li>▪ Conical thrust wear</li> </ul>	<ul style="list-style-type: none"> <li>▪ Replace if any abnormality is observed.</li> <li>▪ Eliminate cause.</li> <li>▪ Clean</li> <li>▪ Replace if any abnormality is observed.</li> <li>▪ Replace if any abnormality is observed. See tolerance chart</li> </ul>
	Front casing	<ul style="list-style-type: none"> <li>▪ Stain in liquid-containing section</li> <li>▪ Are there any cracks?</li> <li>▪ Wear or crack of front thrust ring</li> <li>▪ Expansion or wear of o-ring</li> <li>▪ Scoring on inner surface</li> </ul>	<ul style="list-style-type: none"> <li>▪ Clean</li> <li>▪ Replace if any abnormality is observed.</li> <li>▪ Contact your distributor if any abnormality is observed.</li> <li>▪ Replace if part is damaged</li> <li>▪ Contact your distributor if any abnormality is observed.</li> </ul>
	Spindle	<ul style="list-style-type: none"> <li>▪ Are there any cracks?</li> <li>▪ Wear on surface</li> </ul>	<ul style="list-style-type: none"> <li>▪ Replace if any abnormality is observed.</li> <li>▪ Replace if wear limit is exceeded.</li> </ul>

■ **Wear Limits of Spindle, Bearing, Mouth Ring & Impeller Thrust**

<b>SMD-401</b>	<b>New Inches (mm)</b>	<b>Replace Inches (mm)</b>
Bearing I.D.	1.024 (26.0)	1.064 (27.0)
Spindle O.D.	1.024 (26.0)	0.985 (25.0)
Thickness of mouth ring	0.315 (8.0)	0.236 (6.0)
Impeller thrust (Dimension "A")	0.102 (2.6)	0.039 (1.0)

1. If the difference between Bearing I.D. and Spindle O.D. exceeds 0.039 in (1mm), either the bearing or the spindle, whichever has the greater wear, should be replaced regardless of the values in the above table. In case of a ceramic bearing type pump, the spindle and the bearing should be replaced simultaneously.
2. Initial wear may appear on the sliding parts during the first stages of operation. This should not be mistaken for an abnormal condition.

Note: The spindle of all models can only be replaced with the rear casing, since it cannot be detached. They are an integral unit.

3. The step between the surfaces of the mouth ring and the impeller upon shipment is 0.078 in (mm). Replace the mouth ring when this step is reduced to 0 in.
4. SMD series pumps are designed to have contact between the impeller thrust tip and the spindle face in the event of an abnormal operating condition (cavitation, dry run operation, etc.). If the surfaces are worn out beyond the wear limit “A”, the pump is subject to serious damage. The condition of the surfaces in contact must be checked if an abnormal operation such as dry running or cavitation lasts a total of over 3 hours.

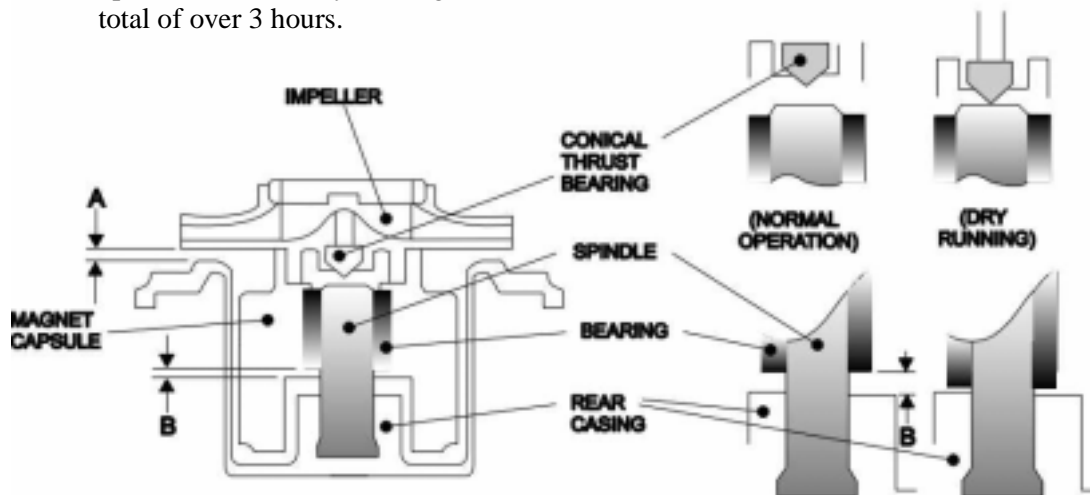
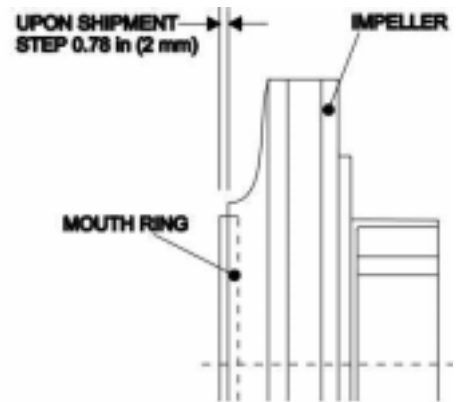

### ■ **Wear Checking Steps**

1. After thorough decontamination of the pump, remove liquid end assembly from motor bracket.
2. Remove front casing from the liquid end.
3. Insert magnet capsule with impeller into rear casing.
4. Measure clearance between backside of impeller shroud and face of rear casing . (Dimension “A”).
5. Physically confirm that clearances are adequate by spinning impeller by hand in rear casing.
  - Tips are not worn out beyond wear limit:  
The impeller and magnet capsule rotate smoothly in the rear casing and there is clearance at the “A”and “B” sections.
  - Tips are worn out beyond wear limit:

The impeller and magnet capsule do not rotate smoothly. Contact between the rear casing and impeller at location “A”, or contact between the rear casing and the magnet capsule bearing at location “B”, as shown in the figure above, does not allow for the continuous smooth rotation of the impeller and the magnet capsule assembly. The tips of the impeller thrust and/or the spindle are excessively worn. In this case, replace the impeller and rear casing.

If no recess or dimple has been created on the spindle face due to wear by the tip of the conical thrust, the rear casing need not be replaced.

Note: If the impeller and magnet capsule spin freely, these parts may continue to be used. If the impeller does not spin freely, this indicates the bearing is contacting the rear casing. The pump must not be operated until the worn or damaged parts have been replaced.

## 8 Troubleshooting

Trouble	Causes	Troubleshooting
Self-priming is impossible or slow. The pump does not self-prime repeatedly.	<ul style="list-style-type: none"> <li>■ The amount of priming liquid is insufficient.</li> <li>■ The pump is operated dry.</li> </ul>	<ul style="list-style-type: none"> <li>□ Stop the pump and feed a sufficient amount of priming liquid. Then restart the pump.</li> </ul>
	<ul style="list-style-type: none"> <li>■ The discharge valve is closed.</li> <li>■ The air bleeding pipe is closed.</li> </ul>	<ul style="list-style-type: none"> <li>□ Open the valve fully and restart the pump.</li> </ul>
	<ul style="list-style-type: none"> <li>■ Air enters inside the pump from the suction pipe of the gasket.</li> </ul>	<ul style="list-style-type: none"> <li>□ Re-check the sealing condition of the coupling flange surfaces on the suction pipe.</li> <li>□ Check to ensure that the water suction level is not too low.</li> </ul>
	<ul style="list-style-type: none"> <li>■ The magnet coupling has disconnected.</li> </ul>	<ul style="list-style-type: none"> <li>□ Measure the current to make sure that the pump is not overloaded.</li> <li>□ Check the impeller and the magnet capsule for any foreign matter between these parts.</li> <li>□ Check that the voltage level is at a normal level.</li> </ul>
	<ul style="list-style-type: none"> <li>■ The RPM of the pump is insufficient.</li> <li>■ The pump rotates in the wrong direction.</li> </ul>	<ul style="list-style-type: none"> <li>□ Check the wiring and the motor and take necessary measures.</li> <li>□ Exchange the connected wires.</li> </ul>
	<ul style="list-style-type: none"> <li>■ The pump is positioned too high.</li> </ul>	<ul style="list-style-type: none"> <li>□ Install the pump to a height within the self-priming limit.</li> <li>□ Check to ensure that the water suction level is not too low.</li> </ul>
	<ul style="list-style-type: none"> <li>■ The specific gravity or viscosity of the liquid is not suitable.</li> <li>■ The temperature of the liquid is too high.</li> </ul>	<ul style="list-style-type: none"> <li>□ Check the temperature, specific gravity and viscosity of the liquid and take necessary measures.</li> </ul>
	<ul style="list-style-type: none"> <li>■ The suction pipe is too long.</li> </ul>	<ul style="list-style-type: none"> <li>□ Shorten the suction pipe.</li> </ul>
	<ul style="list-style-type: none"> <li>■ The frequency is not suitable for the pump.</li> </ul>	<ul style="list-style-type: none"> <li>□ Adjust the frequency to the pump.</li> </ul>
	<ul style="list-style-type: none"> <li>■ The suction pipe is blocked with foreign matter.</li> <li>■ The discharge pipe is blocked with foreign matter.</li> </ul>	<ul style="list-style-type: none"> <li>□ Remove the foreign matter.</li> <li>□ Take measures not to allow the entry of foreign matter.</li> </ul>
	<ul style="list-style-type: none"> <li>■ The suction hose is deformed.</li> </ul>	<ul style="list-style-type: none"> <li>□ Change the hose to a new one having a higher rigidity.</li> </ul>
	<ul style="list-style-type: none"> <li>■ The ends of the discharge pipe and the air bleeding pipe are positioned below the water surface.</li> </ul>	<ul style="list-style-type: none"> <li>□ Raise the ends of the pipes above the water surface.</li> </ul>
	<ul style="list-style-type: none"> <li>■ The suction flange or the cap is loosened.</li> </ul>	<ul style="list-style-type: none"> <li>□ Check the o-ring and tighten if necessary.</li> </ul>
	Discharge rate is too low.	<ul style="list-style-type: none"> <li>■ The suction port is blocked with foreign matter and smooth discharge of liquid is not possible.</li> </ul>
<ul style="list-style-type: none"> <li>■ An air pocket has been created inside the suction pipe.</li> </ul>		<ul style="list-style-type: none"> <li>□ Check the piping conditions and adjust the pipe as necessary.</li> </ul>
<ul style="list-style-type: none"> <li>■ The inlet of the impeller is blocked with foreign matter.</li> </ul>		<ul style="list-style-type: none"> <li>□ Disassemble the impeller section partially and remove the foreign matter.</li> </ul>
<ul style="list-style-type: none"> <li>■ Air enters inside the pump from the suction pipe or the gasket.</li> </ul>		<ul style="list-style-type: none"> <li>□ Check the suction pipe joint and retighten it as necessary.</li> </ul>
<ul style="list-style-type: none"> <li>■ The pump discharge side is blocked with foreign matter.</li> </ul>		<ul style="list-style-type: none"> <li>□ Remove the foreign matter from the pump.</li> <li>□ Remove the foreign matter and/or scales from the pipe.</li> </ul>
<ul style="list-style-type: none"> <li>■ The suction pipe has an air pocket or other type of piping resistance.</li> </ul>		<ul style="list-style-type: none"> <li>□ Check the suction pipe for any projection and take necessary measures.</li> </ul>
<ul style="list-style-type: none"> <li>■ The discharge pipe has a resistant section or the actual pump head and loss of head are too high.</li> </ul>		<ul style="list-style-type: none"> <li>□ Measure the actual pump head and the loss of head of the discharge pipe and take necessary measures.</li> </ul>
The motor is overheated.	<ul style="list-style-type: none"> <li>■ The voltage has dropped greatly.</li> <li>■ The motor is overheated.</li> </ul>	<ul style="list-style-type: none"> <li>□ Check the voltage and the frequency.</li> <li>□ Check to ensure that the specific gravity and viscosity of the liquid are suitable.</li> </ul>
	<ul style="list-style-type: none"> <li>■ The ambient temperature is too high.</li> </ul>	<ul style="list-style-type: none"> <li>□ Ventilate the motor well.</li> </ul>
The discharge rate has dropped suddenly.	<ul style="list-style-type: none"> <li>■ The suction port is blocked with foreign matter.</li> </ul>	<ul style="list-style-type: none"> <li>□ Remove the foreign matter.</li> </ul>

Trouble	Causes	Troubleshooting
Pump vibrates excessively.	<ul style="list-style-type: none"> <li>■ The base is not anchored firmly.</li> <li>■ The installation bolts are loosened.</li> <li>■ The suction pipe is blocked or closed, resulting in cavitation.</li> <li>■ The pump bearing is worn or melted.</li> <li>■ The magnet capsule or the spindle is damaged.</li> <li>■ The dynamic balance of the driving magnet has changed.</li> <li>■ The impeller is in contact with the magnet capsule anchoring part.</li> <li>■ The motor bearing is worn.</li> </ul>	<ul style="list-style-type: none"> <li><input type="checkbox"/> Reinstall the base.</li> <li><input type="checkbox"/> Retighten the bolts.</li> <li><input type="checkbox"/> Clean the pump and get rid of the cause of the cavitation.</li> <li><input type="checkbox"/> Replacement.</li> <li><input type="checkbox"/> Replacement.</li> <li><input type="checkbox"/> Remove the cause or replace the part.</li> <li><input type="checkbox"/> Replacement.</li> <li><input type="checkbox"/> Replace the bearing or the motor.</li> </ul>

## 9 Parts Description and Exploded View

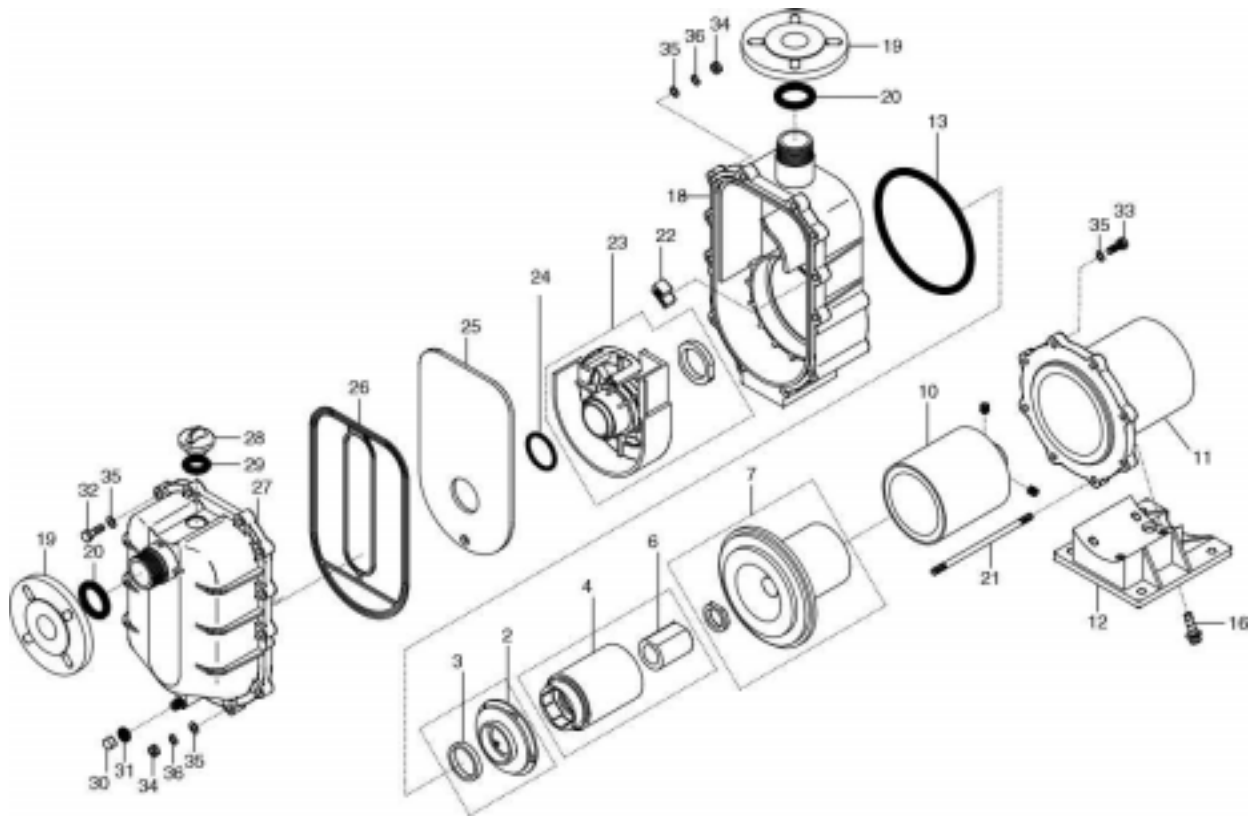

No.	Descrip	Material	Qty	Remarks	No.	Descrip	Material	Qty	Remarks
2	Impeller	GFRPP	1		23	Inner casing	GFRPP	1	
3	Mouth ring	PTFE	1		24	O-ring	FKM	1	G50
4	Magnet capsule	Ferrite + PP	1		25	Plate	PP	1	
6	Bearing	Carbon	1		26	Gasket	FKM	1	
7	Rear casing	GFRPP	1		27	Front casing	GFRPP	1	
10	Drive magnet	Ferrite aluminum alloy	1		28	Cap	GFRPP	1	
11	Adapter	FC200	1		29	O-ring	FKM	1	G30
12	Base	GFRPP	1		30	Cap	GFRPP	1	
13	O-ring	FKM	1	G160	31	O-ring	FKM	1	AS-568-201
16	Bolt	SS	4	M10 x 25	32	Hex head bolt	SS	8	M8 x 50
18	Rear casing chamber	GFRPP	1		33	Hex head bolt	SS	4	M8 x 25
19	Flange	GFRPP	2		34	Nut	SS	12	M8
20	O-ring	FKM	2	ARP568-129	35	Plate washer	SS	20	M8
21	Stud bolt	SS	4	M8	36	Spring washer	SS	16	M8
22	Volute spacer	GFRPP	1						



## 10 Disassembly and Assembly



### Caution!

Since the magnets used in the pump are very powerful, be careful not to get your fingers caught between the elements during disassembly or assembly. Also, keep the magnet away from any electronic device (or ATM card with a magnetic strip) that could be affected by a strong magnetic field.

Prior to servicing, the suction and discharge valves must be closed. The piping and the pump often retain some liquid. It is recommended that the piping and pump cavity be drained prior to servicing.

If dangerous liquid is handled, wear protection and flush pump with clean water or decontaminant prior to service.

Make sure power to the motor is OFF.

### ■ **Disassembly**

1. Remove the pump drain to discharge the liquid out of the pump. Next, loosen the hex head bolts that fix all the parts from the front casing to the rear casing. Then, drain the residual liquid inside the casing and clean inside the pump.
2. Loosen the hex head bolt on the bracket side that fixes the rear casing in place to remove the rear casing.

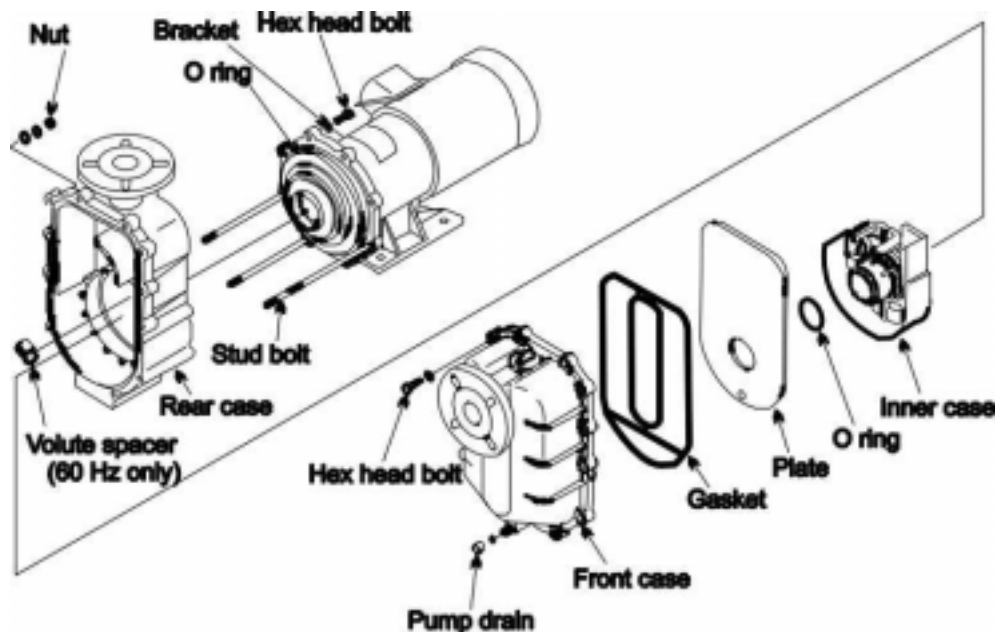

3. Remove the impeller and magnet capsule from the rear casing. Magnet capsule should be kept free of all metal chips. Store in a clean area.
4. Insert a screwdriver into the clearance between the surface of the motor bracket and rear casing. Pull rear casing forward while slightly lifting the screwdriver.

Note: Take care not to damage the sealfaces. Do not remove rear casing assembly unless necessary. Spindle of all models “-D” and “E” cannot be removed.

5. Flush and clean bearing inserted into magnet capsule. Residue in the groove of the bearing causes insufficient lubrication and cooling.
6. To remove drive magnet assembly, stand motor with motor bracket on end (vertically). Loosen 2 set screws with a socket screw key, accessible thru the hole located at the bottom of the motor bracket.
7. Extract drive magnet assembly from motor shaft using a puller or a screwdriver as a handspike. Keep it free of all metal chips and particulate.

### ■ ***Replacement of Bearing***

1. After separating impeller from magnet capsule, prepare a rod with slightly smaller outside diameter than the bearing, and a hand press.
2. Warm magnet capsule assembly in hot water (194°F/90°C) for approximately 20 minutes.
3. Place magnet capsule on the hand press with the impeller side upward. Put the rod on the bearing face. Slowly remove the bearing from magnet capsule by pressing the rod.
4. Place the magnet capsule (impeller side) face down. Place and align new bearing and rod on the magnet capsule. Insert new bearing into the magnet capsule by pressing the rod. If the magnet capsule has cooled too much by this time, warm it again in the same manner as before.
5. Make sure that the bearing is seated at the top of the capsule and protrudes from the bottom of the magnet capsule.

### ■ ***Assembly***

Reassemble the pump by reversing the order of disassembly. Take care not to contaminate or damage the seal faces for o-rings. Tighten bolts uniformly to prevent uneven tightening.

1. Place the drive magnet assembly onto the motor shaft. Ensure that the end of the motor shaft is flush with that of the drive magnet boss. Tighten it with two set screws. Apply Loctite 242 (or equal) as necessary. Check that there is no foreign matter adhering to magnets.
2. Insert rear casing into motor bracket.
3. Install impeller to magnet capsule assembly. Align the impeller and magnet capsule, and with an arbor press, press the impeller into the magnet capsule assembly. Note: Use a flat surface material greater than the mouth ring for

proper alignment. Should the impeller be hard to insert, place magnet capsule in hot water (approx. 194°F, 90°C) for five minutes, then assemble impeller to magnet capsule assembly.

4. Check that there is no foreign matter adhering to magnet capsule assembly.
5. Slowly insert magnet capsule assembly with bearing, impeller and mouth ring into rear casing.



**Caution** Watch fingers! (Strong magnets)

6. Check that there is no dust or defects on the seal faces of front casing and rear casing.
7. Place O-ring into front casing.
8. Mount front casing with O-ring onto rear casing.
9. Tighten front casing bolts diagonally to avoid uneven tightening. See chart below.

Model	Type	Fastening Torque		Size of Bolts
		LBF.IN	Kgf/cm <sup>2</sup>	
SMD-401-D	Hex head bolt	104	120	M8 x 50
				M8 x 25

10. Check with a screwdriver that motor-fan rotates smoothly/freely.

## 11 Spare Parts

---

Appropriate spare parts are necessary to ensure continuous pump operation. Expendable parts, such as bearings, spindles and mouth (thrust) ring should always be kept on hand. Consult your distributor or Iwaki Walchem for the correct part number and pricing. When placing orders, supply the following information.

1. Description and item number (according to this instruction manual).
2. Pump model number and serial number (as shown on the nameplate of the pump).
3. Drawing number if you have received a certified drawing.

## 12 Weights and Dimensions

---

Pump Weight without motor: 24 lbs (10.8 kg) without flywheel  
27 lbs (12.3 kg) with flywheel

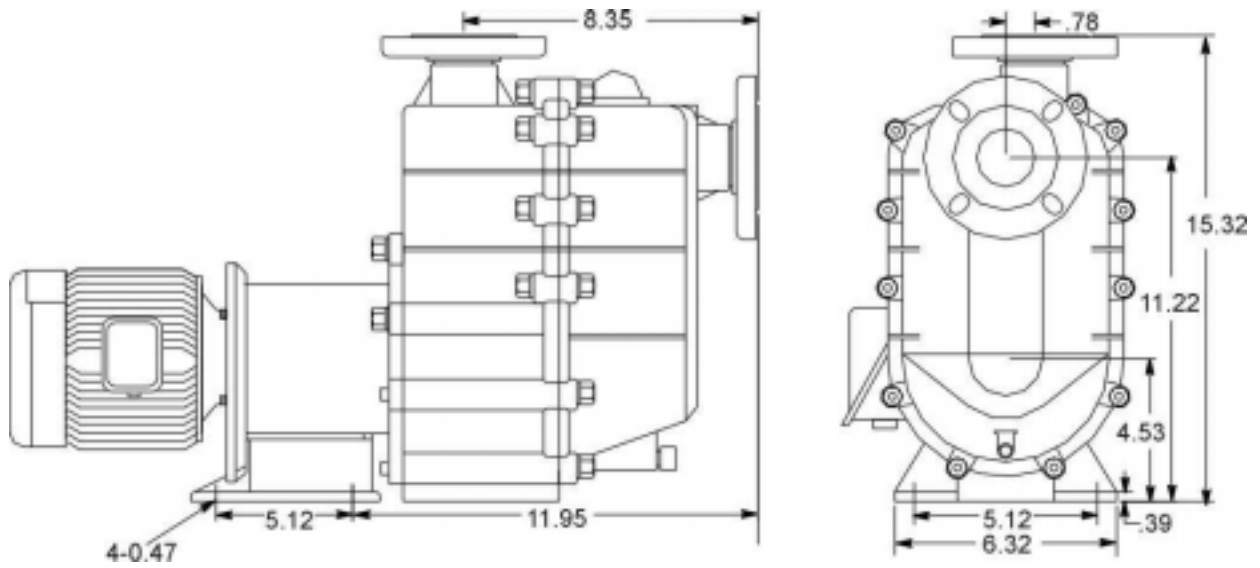

---

IWAKI WALCHEM CORPORATION  
5 BOYNTON ROAD HOPPING BROOK PARK HOLLISTON, MA 01746 USA  
TEL: 508-429-1440 FAX: 508-429-1386 E-MAIL: [IWAKIWALCHEM@IWAKIWALCHEM.COM](mailto:IWAKIWALCHEM@IWAKIWALCHEM.COM)  
ON THE INTERNET AT [WWW.IWAKIWALCHEM.COM](http://WWW.IWAKIWALCHEM.COM)