

**Model 18400-0050**

**SELF-PRIMING PUMP  
FEATURES**

- Body:** Bronze
- Impeller:** Jabsco Neoprene Compound
- Shaft:** 316 Stainless Steel
- Shaft Seal:** Lip Type
- Ports:** 3/4" NPT
- Weight:** 6 lb (approx.)

**APPLICATION**

Marine Engine Cooling

**FOR ENGINE MODELS**

- ONAN MDJ-C
- MDJ-F

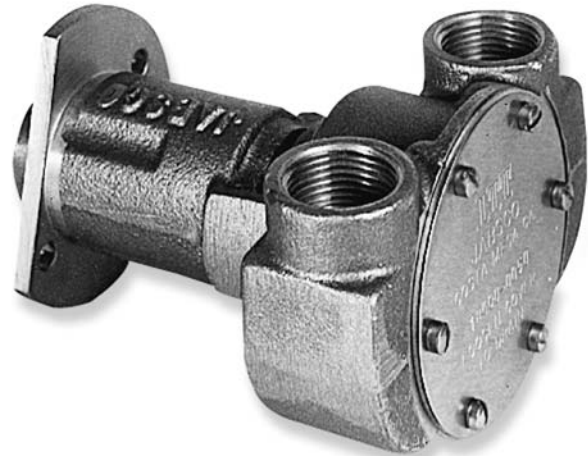

**Model 18400-0050**

**DIMENSIONAL DRAWINGS  
INCHES (MILLIMETERS)**

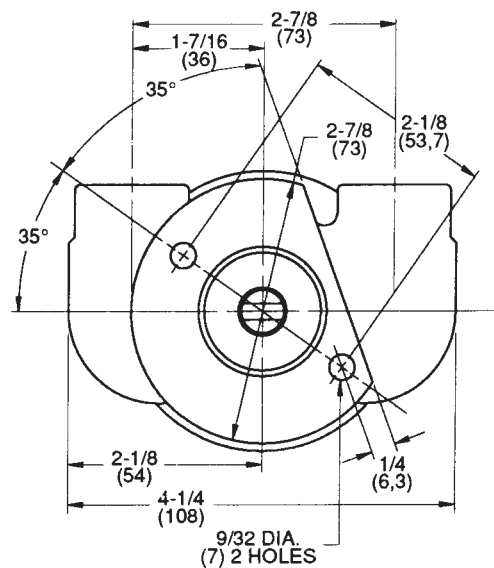
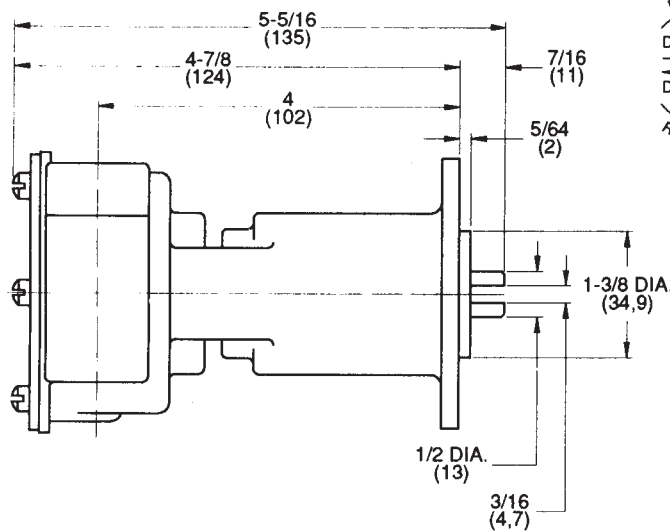

**INSTALLATION INSTRUCTIONS**

Engine shaft with drive tang, make sure flange seats squarely on mounting surface and bolt to engine. Connect inlet and outlet fittings using pipe compound to seal threads.

**OPERATING INSTRUCTIONS**

Pump will self-prime at low or high speeds. Make sure scoop and inlet line are clear and all connections airtight. Do not run pump dry for more than 30 seconds. Lack of water flow may damage impeller. To drain pump, loosen end cover screws.

**SERVICE INSTRUCTIONS**

**Impeller Replacement:** Remove end cover and gasket. Pull impeller out by grasping hub or blades with pliers. Replace impeller, gasket and end cover. A light coating of grease in impeller bore will aid priming on dry start up. (Use correct Jabsco gasket, a thicker or thinner gasket may cause impeller damage.) Standard gasket in 0.010" thick.

**Major Repair:** Remove pump from engine to replace seal, bearings or shaft. To disassemble pump, remove end cover, gasket and impeller as outlined above. Press on impeller end of shaft to remove shaft and bearing

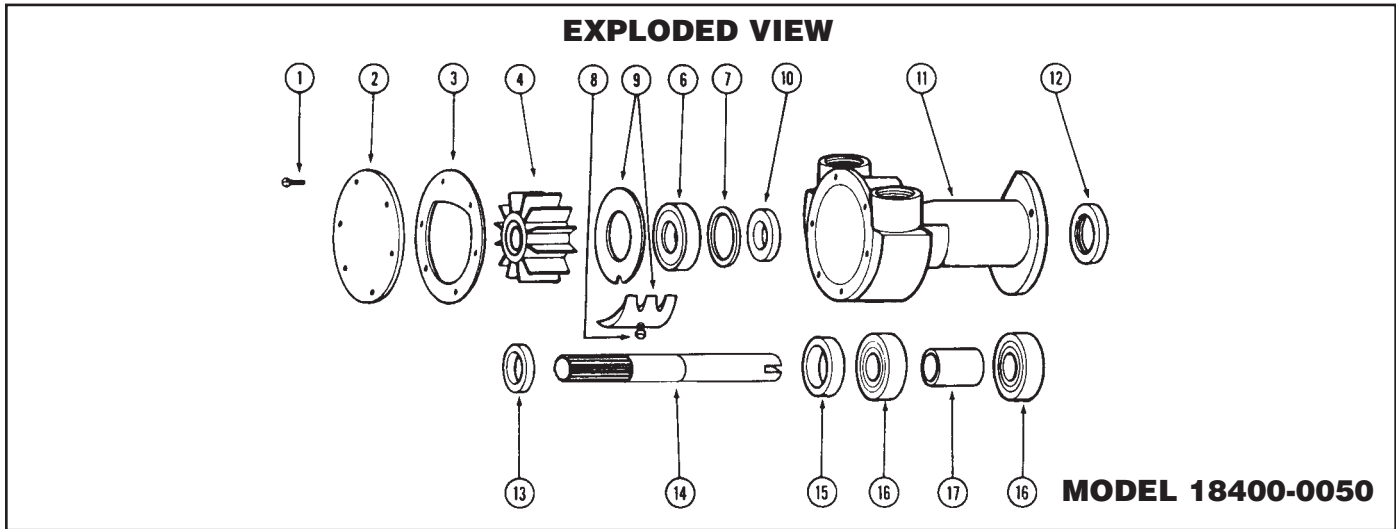

assembly. Remove cam and wearplate assembly. Use screw driver to pry bearing seal out of bearing bore. Press shaft seal out towards impeller bore. Replace all worn parts. When installing coupling, support splined end of shaft. Press bearing seal in bearing bore with lip towards bearing. Press shaft and bearing assembly into bearing bore. Press adaptor ring into body. Install slinger on shaft. Install seal spacer in seal cavity. Install O-ring in seal bore. Press seal in seal cavity with lip facing toward impeller bore. Apply a thin coat of sealant to top of cam and cam screw threads, install wearplate and cam assembly. (Be sure cam is flush with end cover surface.) Secure with screw. Lubricate impeller bore, install impeller. Lubricate impeller face, install gasket and end cover and secure with screws.

**PARTS LIST**

Key	Description	Qty.	Part No.
1	Screw (End Cover)	6	91002-0020
2	End Cover	1	11830-0000
*3	Gasket	1	5212-0000
*4	Impeller	1	1210-0001
*6	Seal (Shaft)	1	92700-0060
*7	O-Ring†	1	92000-0210
8	Screw (Cam)	1	91003-0090
9	Cam Wearplate Assembly	1	5211-0000
10	Seal Spacer	1	3166-0000
11	Body	1	
12	Adaptor Ring	1	3376-0000
13	Slinger	1	3286-0000
14	Shaft	1	18404-0000
15	Bearing Seal	1	92700-0060
16	Ball Bearing	1	92600-0130
17	Bearing Spacer	2	3383-0000
	Service Kit		90033-0001

\* Parts contained in Service Kit.

† O-ring used only in pumps manufactured prior to June, 1993.

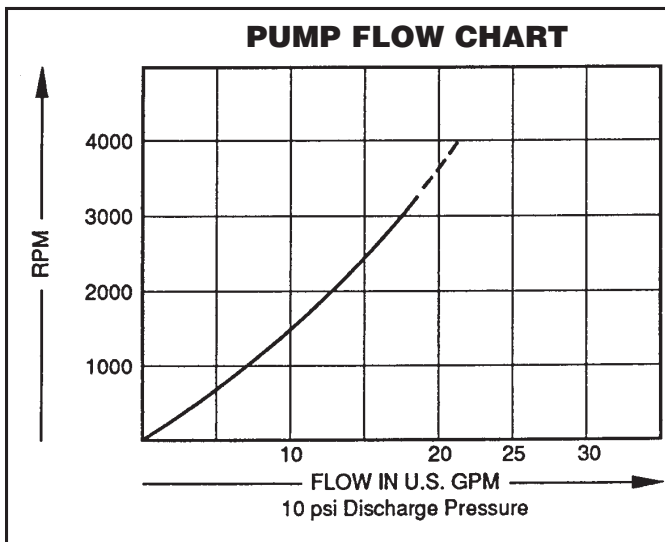

**Jabsco**



U.S.A.  
Jabsco  
1485 Dale Way, P.O. Box 2158  
Costa Mesa, CA 92628-2158  
Tel: (714) 545-8251  
Fax: (714) 957-0609

UNITED KINGDOM  
Jabsco  
Bingley Road, Hoddesdon  
Hertfordshire EN11 0BU  
Tel: +44 (0) 1992 450145  
Fax: +44 (0) 1992 467132

CANADA  
Fluid Products Canada  
55 Royal Road  
Guelph, Ontario N1H 1T1  
Tel: (519) 821 -1900  
Fax: (519) 821-2569



THE PRODUCTS DESCRIBED HEREIN ARE SUBJECT TO THE JABSCO ONE YEAR LIMITED WARRANTY, WHICH IS AVAILABLE FOR YOUR INSPECTION UPON REQUEST.

JAPAN  
NHK Jabsco Company Ltd.  
3-21-10, Shin-Yokohama  
Kohoku-Ku, Yokohama, 222  
Tel: 045-4758906  
Fax: 045-475-8908

GERMANY  
Jabsco GmbH  
Oststrasse 28  
22844 Norderstedt  
Tel: +49-40-53 53 73 -0  
Fax: +49-40-53 53 73 -11