



Model: 37075-Series

DESIGNER STYLED MARINE TOILET With Quiet-Flush System

FEATURES

- Very quiet flush cycle—like a household toilet
- Single button flush actuator—with dual function water level control switch
- All toilet plumbing and wiring connections are internal-out of sight
- Supplied with Solenoid Valve and Siphon Breaker to control bowl rinse water from any pressurized system that provides 3-1/2 gpm minimum.
- Solenoid Valve and Siphon Breaker assembly allows toilet to be plumbed to potable water.
- Vitreous china bowl available in compact 14" height or standard 17" height
- Available in White or Bone
- Sturdy designer molded plastic seat & cover
- High capacity waste macerator and bowl discharge pump

SPECIFICATIONS

Ports:	Inlet – 3/4" Hose Barb Outlet – 1" Hose Barb
Motor & Switch:	Toilet Meets U.S.C.G. Regulation 183.410 and ISO 8846 MARINE for Ignition Protection. Toilets are marked CE and comply with EN50081-1 for suppression of electromagnetic interference.
Normal Water Consumption:	1-2 Quarts (Litres)/Flush



Model: 37075-Series



Model Number	Description
37075-0092	Compact White Toilet 14", 12 Volt EMC
37075-2092	Compact Bone Toilet 14", 12 Volt EMC
37075-0094	Compact White Toilet 14", 24 Volt EMC
37075-2094	Compact Bone Toilet 14", 24 Volt EMC
37075-1092	Standard White Toilet 17", 12 Volt EMC
37075-3092	Standard Bone Toilet 17", 12 Volt EMC
37075-1094	Standard White Toilet 17", 24 Volt EMC
37075-3094	Standard Bone Toilet 17", 24 Volt EMC

OPERATION

The Designer Styled Toilet with the popular Quiet-Flush system provide both quiet operation and user control of water levels in the toilet bowl. A single large push-button switch provides a simple flush mode by activating both the rinse water supply and the macerator discharge pump simultaneously. An additional rocker switch offers independent control of the rinse water supply and discharge

pump separately so the bowl water level can be easily raised or lowered by the user. This provides a method of minimizing water use, when desired, as well as a means of raising the water level in the bowl when appropriate for user comfort. It also allows for complete evacuation of the bowl water while underway in rough sea conditions.

INSTALLATION

The 37075-Series Designer Styled Toilet includes the Quiet-Flush Toilet pumping system and is supplied with a solenoid valve/siphon breaker to control the supply of rinse water to the toilet bowl. The siphon breaker prevents the potential for contamination of the water so the toilet can be flushed with potable water. The toilet also includes a multi-function flush control which should be installed in a bulkhead location that is convenient to the toilet and allows access for wiring to run from the power source and to both the toilet discharge pump and solenoid valve/siphon breaker. Because all plumbing and wiring connections at the toilet are made internally within the china bowl, all plumbing and wiring must be completed and extended to the toilet location prior to final installation of the toilet.

Install the toilet seat and lid assembly on the china bowl with the fasteners provided and position the toilet in its desired location. When locating the toilet, ensure there is adequate clearance above the bowl so the seat and lid assembly can rotate to its fully open position and remain open on its own. Once the exact position has been determined, mark the location of the two toilet mounting holes on the toilet mounting surface and move the toilet, temporarily, out of the way. When securing the toilet to a plywood underlayment below a layer of fiberglass, to avoid cracking the fiberglass, drill a 5/16" (8 mm) hole through just the fiberglass layer to provide clearance for the screw threads and shank. Drill a 3/16" (5 mm) pilot hole to accept the threaded portion of the toilet hold-down screw set provided. It is generally best to wait until the toilet is ready to be installed for the final time before screwing the hold-down screw into the mounting surface.

To make the water connection, shut off the water system pump and open one of the systems faucets or fixtures to drain the pressure from the system. Select an appropriate tee type fitting that can be installed in the existing pressurized water system and will provide a 1/2" (13 mm) hose barb to feed water to the toilet. Install the tee fitting at a location on the pressurized water system that provides convenient connection to the toilet's solenoid valve/siphon breaker assembly. If the toilet is being connected to the vessel's fresh water system and the vessel may be connected to an unregulated city water supply, it is recommended that a valve be installed in the toilet water supply line ahead of the solenoid valve/siphon breaker to regulate the flow rate of incoming pressurized city water.

The solenoid valve/siphon breaker should be positioned a minimum of six inches above the hose connection at the back of the toilet bowl and located as close to the toilet as possible. It must be installed in a vertical position with the hose barb connections pointing down. The solenoid valve/siphon breaker bracket should be secured to a solid mounting surface with four screws. If the valve

assembly is attached to a wood surface, 3/8" (10 mm) long screws are generally adequate to support the weight of the valve assembly. If desired, the valve assembly may be installed inside a cabinet or locker to conceal it from view of the vessel's occupants. Run a length of 3/4" hose from the barb at the back of the bowl to the siphon breaker discharge port.

The solenoid valve inlet hose barb is then connected with 1/2" (13 mm) reinforced vinyl hose suitable for pressurized water to the tee fitting installed in the water system line. All pressurized water system connections should be secured with stainless steel band type hose clamps. The hose connecting the siphon breaker to the bowl should be secured with a band clamp at the siphon breaker to prevent it from being accidentally dislodged but generally does not need a hose clamp to secure it to the bowl spud fitting unless desired for added security.

The toilet discharge port is sized for 1" (25 mm) hose. The discharge hose should be a quality grade reinforced hose suitable for waste applications. Route the discharge hose to the holding tank in the most direct way with as few bends as possible. To retain some water in the bowl, it is best to loop the discharge hose up about 8-10 inches (15-20 cm) as close to the toilet as practical then on the holding tank. Providing adequate length of hose to include such a loop also will provide the ability to move the toilet out away from the bulkhead it butts against to complete the hose connections. It is best to avoid any dips or low spots in the discharge plumbing that can act as water traps and collect waste as it runs on to the holding tank. If this occurs, waste can solidify and cause a discharge blockage.

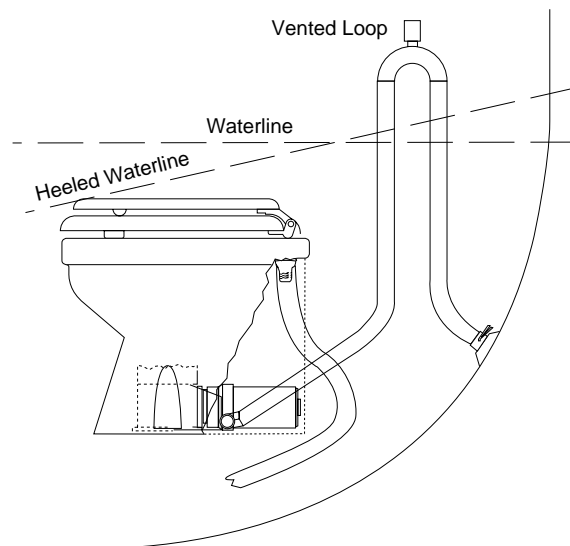

If the toilet is plumbed to an overboard discharge, and is below the vessel's waterline, the discharge plumbing must include a properly positioned vented loop. The vented loop fitting must be secured in a location that remains at least 6-8 inches (15-20 cm) above the waterline at all angles of heel and trim. The maximum discharge head without a notable decrease in pump performance is four feet (1.3 M).

 WARNING	Flood hazard. If toilet is installed below the waterline or may be below the waterline at any angle of heel or trim, it must be installed with properly positioned vented loops. Failure to do so can result in flooding which can cause loss of property and life.
--	--

Ensure each hose end is pushed completely onto its port fitting and secure each with a hose clamp. All hose connections made below the waterline should be secured with two stainless steel band clamps. It is best to secure the hoses in place about every eighteen inches along the length of the run.

Once all hose connections are completed and secured with clamps, it is best to complete the wiring so the toilet can be tested for leaks prior to fastening it to its mounting surface. Once the electrical wiring is complete, test the toilet by flushing several times and blot all hose termination's completely around each connection with a white paper towel and inspect the towel for wet spots. If the towel comes away dry from each connection within the china bowl, proceed to fasten the toilet to its mounting surface.

Position the toilet in its intended mounting position and very gently, with a 10 mm wrench, screw the provided toilet hold-down fastener into the pilot hole drilled earlier. Do not overtighten these fasteners as this may crack the china. It is only necessary to make the fasteners snug enough to prevent the toilet from sliding around. Screw the dress cap into the top of the hold-down screw.

ELECTRICAL

The electrical wiring should be independent of all other accessories. It should be made with marine grade copper stranded wire of the gauge specified in the electrical specifications chart. Make all wire connections with mechanical locking type connectors (crimp type butt connectors and terminals). Ensure the circuit is protected by a proper sized fuse or circuit breaker determined from the electrical specifications chart. Secure all wires to a solid surface approximately every eighteen inches (1/2 M) along their entire length of run.

Wire the switch panel to the solenoid valve/siphon breaker and toilet pump assembly as per the following wiring diagram. Select a location for the switch panel that is convenient to the toilet user and that will also allow access to run the wires from the switch panel to both the toilet's motor and the solenoid valve/siphon breaker as well as from the electrical power source to the switch panel. Connect the brown lead from the panel to the waste pump positive (orange) motor lead. Connect the black waste pump motor lead to battery negative. Connect the yellow lead from the panel to a solenoid valve terminal. Connect the remaining solenoid valve terminal to battery negative. The valve solenoid is not polarity sensitive.

To install the switch panel, drill two 1-3/4" (45 mm) diameter holes (slightly over-lapping) through the selected switch mounting surface per the attached template. Ensure the template is oriented correctly because it is not symmetrical. Also, drill four appropriate sized holes for the fasteners selected to secure the switch panel to its mounting surface.

ELECTRICAL SPECIFICATIONS

VOLTAGE	AMP DRAW	FUSE SIZE	WIRE SIZE PER FEET OF RUN*				
			0'-10' (0 M-3 M)	10'-15' (3 M-4,6 M)	15'-25' (4,6 M-7,6 M)	25'-40' (7,6 M-12,2 M)	40'-60' (12,2 M-18,3 M)
12 Vdc	10	25	#16 (1,5 mm ²)	#14 (2,5 mm ²)	#12 (4 mm ²)	#10 (6 mm ²)	#8 (10 mm ²)
24 Vdc	5	15	#16 (1,5 mm ²)	#16 (1,5 mm ²)	#16 (1,5 mm ²)	#14 (2,5 mm ²)	#12 (4 mm ²)

* Length of run is total distance from power source to product and back to ground.

TEMPLATE

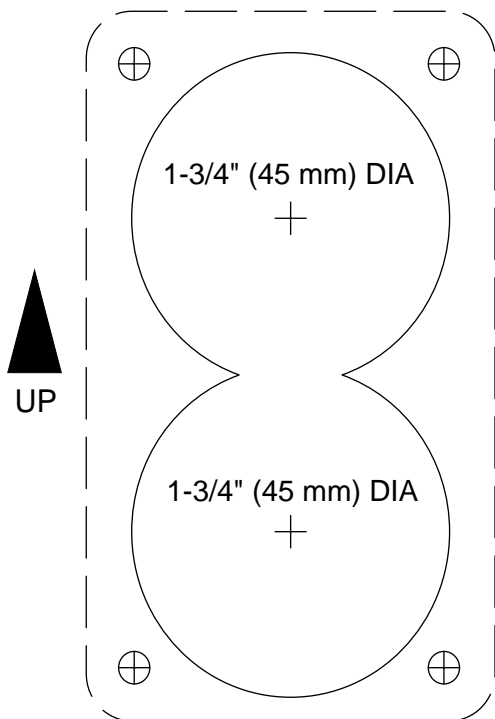

WIRING DIAGRAM

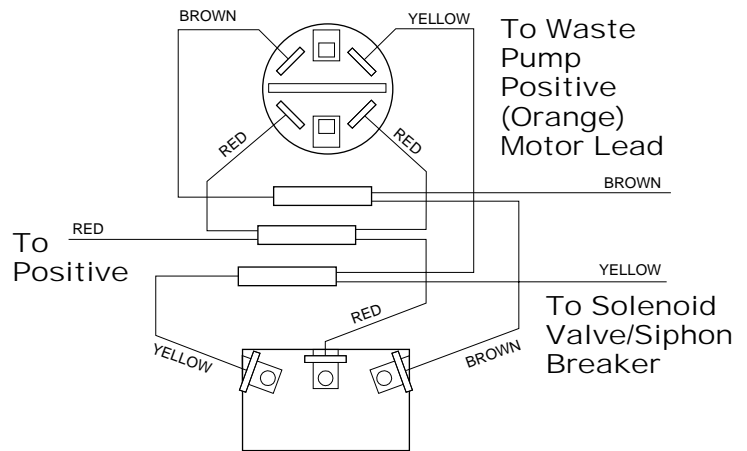

WASTE PUMP SERVICE

The Jabsco Quiet-Flush Toilet does not require routine maintenance other than occasional cleaning to maintain a hygienic sanitary condition. Clean toilet with mild non-abrasive cleaners without strong aromatics. Cleaners having high concentrations of aromatics such as pine scented concentrated cleaners and strongly scented degreaser concentrates can cause the pump's seal to swell and may contribute to a premature seal leak.

The toilet has no wearing parts that need periodic replacement other than the shaft seal which, under normal conditions, should provide several years of service before needing replacement. The seal only requires replacement if signs of leakage are noticed around the base and rear of the toilet china bowl.

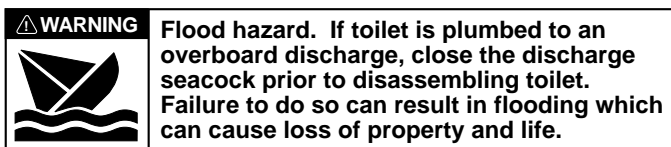

NOTICE: Before performing any service, turn off the electrical power to the toilet and rinse water pump. Take precaution to ensure it is not turned on until the service is complete. Also, pump all water from the toilet bowl and if connected to an overboard discharge, close the discharge seacock.

To replace the shaft seal, remove the two toilet hold-down screw caps and remove the hold-down screw nuts. Carefully lift the toilet up and away from the bulkhead at its rear. Remove the pump assembly by removing the four screws with lock washers that secure it to the plastic toilet base. Carefully slide the pump assembly from the base ensuring the macerator housing also slides out of the base with the pump. The pump chopper will engage the macerator housing and it may be necessary to gently tap the chopper against the macerator housing to free it from the base.

Prevent the motor shaft from turning by inserting a screwdriver in the shaft slot at the rear of the motor and unscrew the chopper. Remove the chopper, lock washer and macerator housing from the motor shaft. Remove the O-ring from the O-ring groove around the outer diameter of the seal housing. With an allen wrench, loosen the centrifugal impeller set screw and slide the impeller off the shaft. Remove the two screws that secure the seal housing to the motor and slide the housing off the motor shaft. Remove the two seal washers from under the head of each of the two seal housing retainer screws. With a pair of needle nose pliers, grasp the shaft seal and pull it from the seal housing. Clean all parts and inspect for damage.

Lubricate the OD of the new seal with a small amount of water and press it into the seal bore with the seal's lip facing the threaded end of the shaft. *Do not use the stainless steel star retaining washer supplied with the seal.* Lubricate the ID of the seal and the motor shaft

with a small amount of water resistant grease. Ensure the slinger is properly positioned on the motor shaft next to the motor and slide the seal housing onto the motor shaft until it is against the motor end bell. Position a new plastic seal washer under the head of each of the flat head seal housing retainer screws and secure the seal housing to the motor. Slide the centrifugal impeller on the motor shaft positioning it about 1/32" (1 mm) from the seal housing and secure it to the shaft with the set screw. Rotate the impeller to ensure it does not rub on the seal housing.

Slide the macerator housing over the motor shaft, place the lock washer on the end of the shaft and screw the chopper onto the shaft. Tighten the chopper while holding the motor shaft at the rear of the motor. Position a new O-ring in the seal housing O-ring groove (it may be retained in the groove with a small amount of grease). Slide the pump assembly into the toilet base ensuring the macerator housing is properly positioned within the base. The cut-out in the side of the macerator housing must align with the discharge port in the base (the macerator housing is keyed so it will only go in when properly positioned). Ensuring the O-ring is still properly positioned in the O-ring groove in the seal housing, place the pump assembly against the base and secure it in place with the four screws and lock washers.

Carefully lift the toilet and position over the two hold-down screws using caution not to chip or break the china. Secure the toilet down with the hold-down nuts and washers ensuring the plastic washer is next to the china.

Do not overtighten hold-down nuts.

EXPLODED VIEW

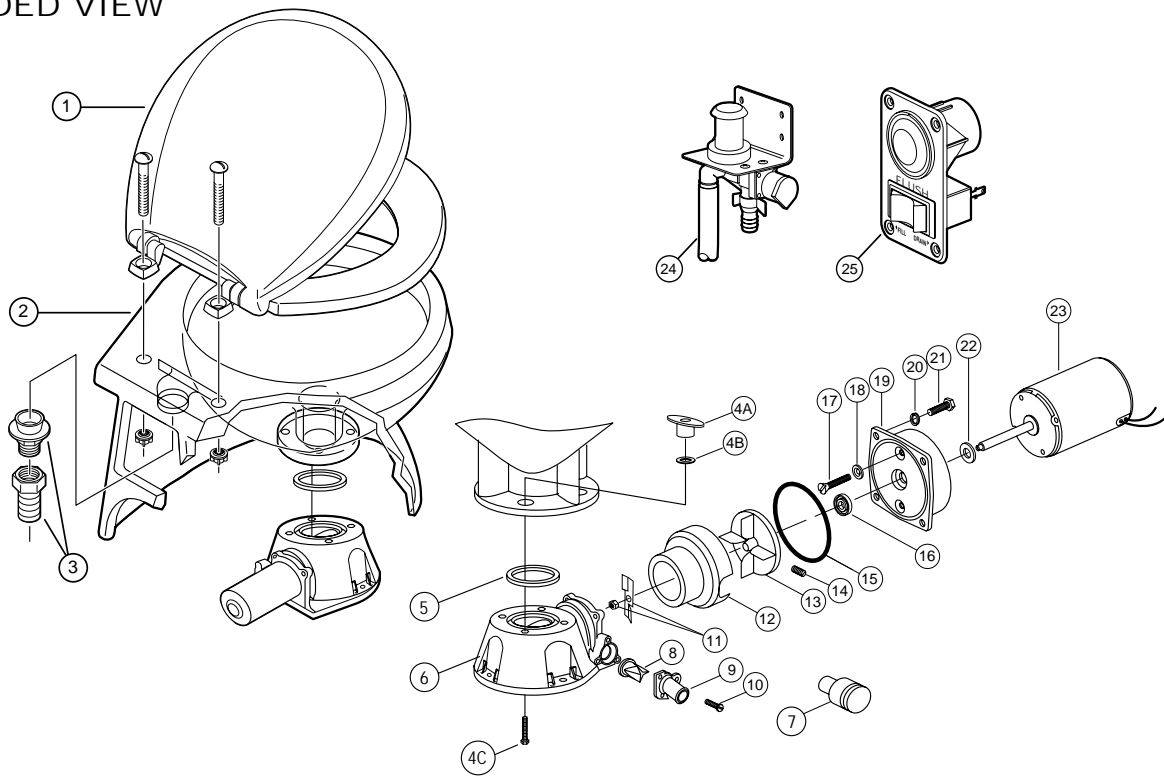

PARTS LIST

Key	Qty.	Description	Part Req.	Number	Key	Qty.	Description	Part Req.	Number
1		Seat & Cover	1	37078-1000	16		Seal	1	1040-0000
2		Bowl, Compact Size, White	1	37076-0010	17		Screw	2	91010-0144
		Bowl, Standard Size, White	1	37076-1010	18		Washer, Plastic*	2	35445-0000
		Bowl, Compact Size, Bone	1	37076-2010	19		Seal Housing	1	37043-1000
		Bowl, Standard Size, Bone	1	37076-3010	20		Lock Washer #10, Stainless Steel	4	
3		Bowl Spud and 3/4" barbed adaptor	1	18753-0609	21		Screw	4	91027-0011
4		Bowl Installation Hardware	1	18753-0604	22		Slinger	1	6342-0000
4A		Tee Nut**	4		23		Motor - 12 Volt EMC	1	18753-0582
4B		Washer, Plastic**	4				Motor - 24 Volt EMC	1	18753-0583
4C		Socket Head Screw**	4		24		Solenoid Valve/Siphon Breaker		
5		Gasket*	1	37017-0000			12 Volt EMC	1	37038-1012
6		Base Assembly**	1	37004-1000			24 Volt EMC	1	37038-1024
7		1-1/2" Adaptor, Discharge Port	1	98023-0080	25		Switch Panel	1	37047-1000
8		Joker Valve* **	1	44106-1000			Service Kit	1	90197-0000
9		1" Discharge Port**	1	37077-1000			Waste Pump Assembly		
10		Screw**	3	96050-0568			12 Volt EMC	1	37072-0092
11		Chopper Plate with Lock Nut,	1	37056-1000			24 Volt EMC	1	37072-0094
12		Macerator Housing	1	37014-0000					
13		Centrifugal Impeller	1	37006-0000					
14		Set Screw	1	18753-0492					
15		O-ring*	1	43990-0066					

* Parts supplied with Service Kit.

** Parts included with base 37004-1000.

DIMENSIONAL DRAWINGS Inches (Millimeters)

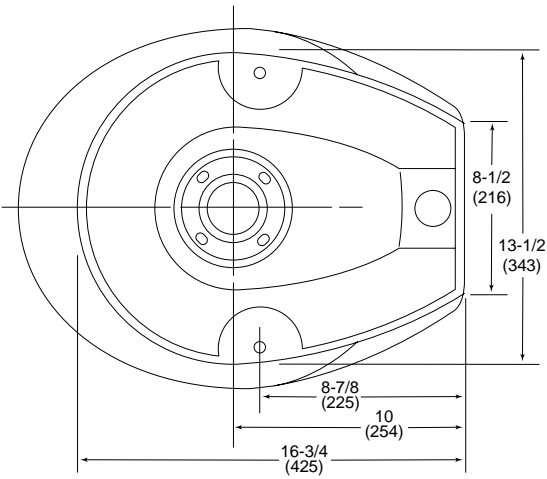
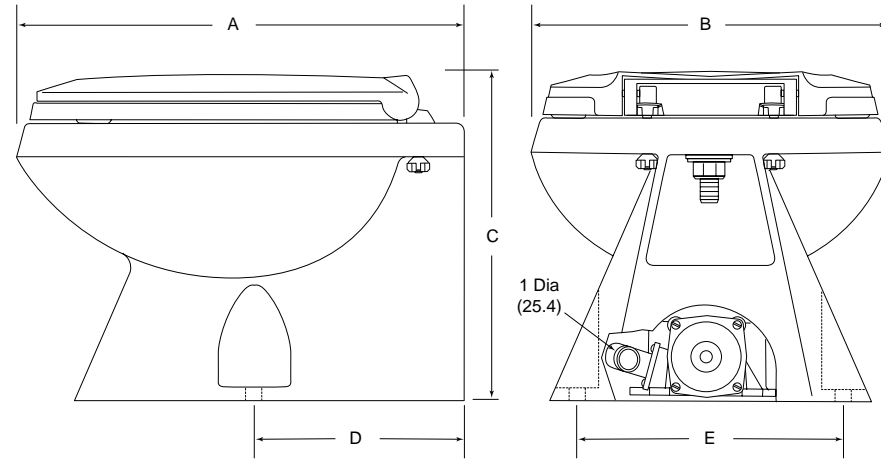

	Compact Size Bowl	Standard Size Bowl
A	19-3/16 (487)	19-3/16 (487)
B	15-1/2 (394)	15-1/2 (394)
C	14-1/4 (362)	17-1/4 (438)
D	8-7/8 (225)	8-7/8 (225)
E	11-13/16 (300)	11-13/16 (300)

ONE YEAR LIMITED WARRANTY

A. LIMITED WARRANTY:

ITT warrants that at the time of shipment, the products manufactured by ITT and sold hereunder shall be in conformity with applicable written specifications and descriptions referred to or set forth herein, free from defects in material and workmanship, merchantable, and suitable for a particular purpose, provided such is implied by State law under the circumstances of this sale.

B. WARRANTY ADJUSTMENT:

1. ITT agrees to repair or furnish a replacement for, but not to remove or install, any product or component thereof which, within one (1) year from date of purchase, shall upon test and examination by ITT prove defective within the above warranty. Receipt verifying purchase date is required to obtain adjustment.
2. Buyer shall notify ITT of any defect within this warranty no later than ninety (90) days after the defect is discovered.
3. No product will be accepted for return or replacement without the prior written authorization of ITT. Upon such authorization, and in accordance with instructions from ITT, the product will be returned to ITT, shipping charges prepaid by Buyer. Products returned to ITT will be addressed as follows:

ITT JABSCO

1485 Dale Way

Costa Mesa, California 92626-3998

Or to such alternate locations as may be designated on the product, its container, or this sheet. Repair or replacement made under this warranty will be shipped prepaid to Buyer.

C. EXCLUSIONS FROM WARRANTY AND LIMITATION OF LIABILITY:

1. The foregoing warranty is limited solely as set forth herein and applies only for the period designated above.
2. ITT SHALL NOT BE LIABLE FOR ANY LOSS, DAMAGE, SPECIAL OR CONSEQUENTIAL DAMAGE OF

ANY KIND, WHETHER BASED UPON WARRANTY, CONTRACT, NEGLIGENCE, OR STRICT LIABILITY ARISING IN CONNECTION WITH THE SALE, USE, OR REPAIR OF THE PRODUCT.

3. THE MAXIMUM LIABILITY OF ITT IN CONNECTION WITH THIS WARRANTY SHALL NOT IN ANY CASE EXCEED THE CONTRACT PRICE FOR THE PRODUCT CLAIMED TO BE DEFECTIVE OR UNSUITABLE.
4. This warranty does not extend to any product manufactured by ITT which has been subjected to misuse, neglect, accident, improper installation, or use in violation of instructions furnished by ITT.
5. This warranty does not extend to or apply to any unit which has been repaired or altered at any place other than ITT's factory, or by persons not expressly approved by ITT, nor to any unit the serial number, model number, or identification of which has been removed, defaced or changed.
6. Components manufactured by any supplier other than ITT shall bear only that warranty made by the manufacturer of that product.
7. This warranty applies to products defined as "consumer products" by the Consumer Product Warranties Act as from time to time amended.

D. CONSUMER RIGHTS:

This warranty gives you specific legal rights, and you may have other rights which vary from state to state. Some states do not allow exclusion or limitation of damages.

STANDARD WARRANTY:

If the products manufactured and sold hereunder are not Consumer Products, the warranty extended to Buyer shall be as set forth in subparagraphs (A), (B), and (C), **EXCEPT THAT ALL EXPRESS OR IMPLIED WARRANTIES OR MERCHANTABILITY OR SUITABILITY FOR ANY PARTICULAR PURPOSE ARE EXCLUDED.**

Jabsco



ITT Industries
Engineered for life

U.S.A.
Jabsco
1485 Dale Way, P.O. Box 2158
Costa Mesa, CA 92628-2158
Tel: (714) 545-8251
Fax: (714) 957-0609

UNITED KINGDOM
Jabsco
Bingley Road, Hoddesdon
Hertfordshire EN11 OBU
Tel: +44 (0) 1992 450145
Fax: +44 (0) 1992 467132

CANADA
Fluid Products Canada
55 Royal Road
Guelph, Ontario N1H 1T1
Tel: (519) 821 -1900
Fax: (519) 821-2569

JAPAN
NHK Jabsco Company Ltd.
3-21-10, Shin-Yokohama
Kohoku-Ku, Yokohama, 222
Tel: 045-4758906
Fax: 045-475-8908

GERMANY
Jabsco GmbH
Oststrasse 28
22844 Norderstedt
Tel: +49-40-53 53 73 -0
Fax: +49-40-53 53 73 -11

THE PRODUCTS DESCRIBED HEREIN ARE SUBJECT TO THE JABSCO ONE YEAR LIMITED WARRANTY, WHICH IS AVAILABLE FOR YOUR INSPECTION UPON REQUEST.