

### MARINE ENGINE COOLING WATER PUMP FEATURES

#### FEATURES

Body:	Bronze
Impeller:	Jabsco Neoprene
Shaft:	Stainless Steel
Ports:	1" NPT Internal
Seal:	Mechanical Face Type
Bearings:	Sealed Ball Type
Shipping Weight:	8 lb (3,6 kg)

#### APPLICATION

Engine Cooling Water Pump for Crusader\* Engines. Replaces Crusader Model 97179 (Sherwood E-35).

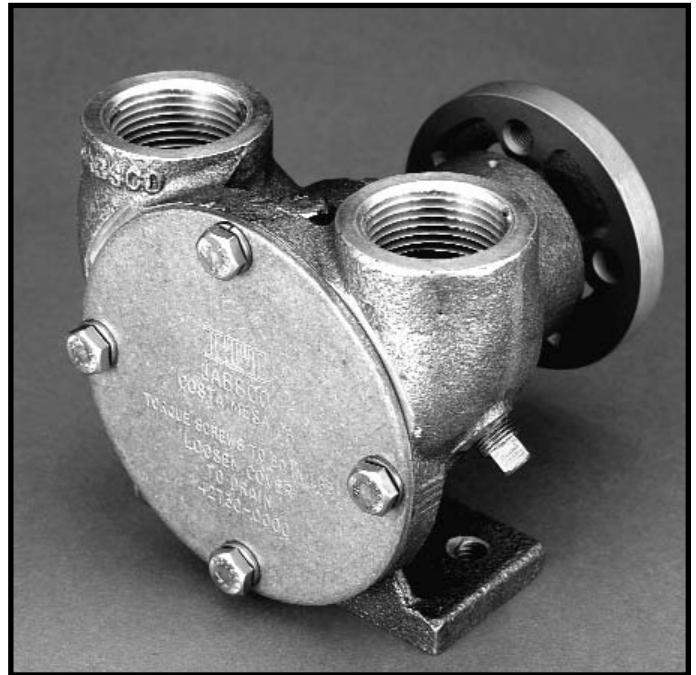

Model: 42730-0000

#### APPLICATION

The Jabsco Engine Cooling Pump for Crusader engines is designed to be a direct replacement for the stock Crusader pump Model Number 97179 (Sherwood E-35). It accepts the stock Crusader pulley and bolts directly to the Crusader mounting bracket. The 1" NPT internal threads in the ports accept the stock hose adaptors.

The Jabsco pump impeller can be used in either the Jabsco pump or the stock Crusader pump replacing the Crusader impeller Number 20300.

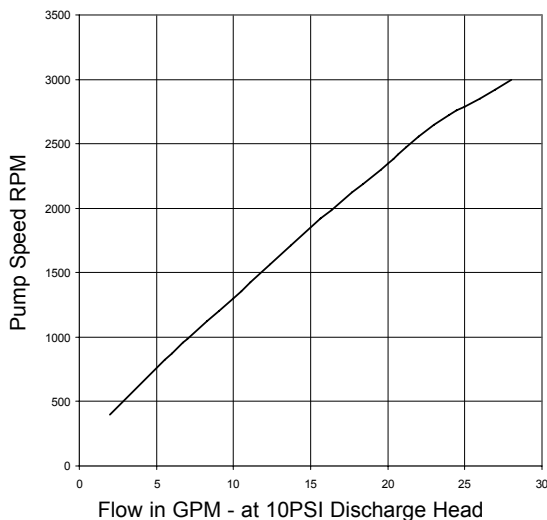

#### INSTALLATION

The Jabsco replacement pump for Crusader engines is installed in the same manner as the stock pump. Simply attach the pump base to the pump mounting bracket with two 3/8-16 screws and lock washers. Attach the drive pulley to the pulley adaptor with four machine screws and lock washers. Position the drive belt in the pulley groove then re-tension the belt and secure the pump mounting bracket. Torque the four pulley mounting screws to 130-140 in. lb. It may be necessary to apply a slight lateral load to the belt to prevent the pulley from rotating while torquing the pulley mounting screws. Clean the threads of both port hose adaptors and apply a couple wraps of Teflon\*\* tape to the threads of each. Screw one adaptor into each port ensuring, while tightening, that the hose barb aligns with the appropriate hose to be connected. Attach the inlet and discharge hoses to the port adaptors and secure them with marine grade hose clamps. It is generally considered a good practice to install two hose clamps to all hose terminations on hoses that ultimately attach to an underwater thru-hull fitting.

\* Crusader is a registered trademark of Thermo Electron Corporation.

\*\* Teflon is a registered trademark of E.I. DuPont de Nemours and Company.

## SERVICE

### WARNING



**Flood hazard. Before performing any service, close all waste system seacocks. Failure to do so can result in flooding which can cause loss of property and life.**

In order to perform service work on the pump, it is necessary to remove the pump from its mounting bracket. After closing the inlet seacock disconnect both hoses from the port adaptors. Some residual water will flow from the hoses but should stop after a few seconds. If the pump seal is to be replaced it is advisable to loosen, but not yet remove, the four screws that secure the pulley to the pulley adaptor. If need be, remove one or both port adaptors to allow access to the mounting bracket screws. Loosen the drive belt tension and remove the belt from the pulley groove. Now remove the four screws that secure the pulley to the pulley adaptor and remove the pulley. Remove the two pump mounting bolts and remove the pump from the bracket.

Because the Jabsco pump is designed for ease of service, it should not be necessary to remove the shaft for most service requirements.

### DISASSEMBLY

Remove the four end cover screws and lock washers. Remove the end cover and end cover O-ring. With a pair of water pump pliers grasp the hub of the impeller and with a rotary motion pull the impeller from the impeller bore. Remove the impeller drive key from the shaft. Remove the cam screw and its O-ring and remove the cam from the impeller bore. Remove the wearplate from the bottom of the impeller bore. Now, it should be possible to push the seal components out of the seal bore with two small tip screwdrivers inserted between the impeller housing and bearing housing segments of the pump body.

**NOTICE:** Use care not to scratch the shaft. A new seal may not function properly if the shaft is scratched.

From the opposite sides of the pump insert two screwdriver tips into the seal area (between pump body and bearing housing connector ribs) and carefully push screwdrivers between the seal ceramic (white disc) and the side of the bearing. Then pry the seal components away from the bearing and into the impeller bore. Reach into the impeller bore and slide the seal components off the shaft. Ensure the O-ring (in the ceramic) comes off the shaft with the ceramic. If the O-ring is still positioned around the shaft next to the bearing, it must be removed prior to installing a new seal. There is another larger O-ring in the seal bore inside the impeller housing which must be removed. With an O-ring removal tool or thin hooked wire reach into the impeller bore, hook the O-ring and pull it from the O-ring groove.

Clean all brass parts and inspect for wear. If the wearplate has wear grooves on it which can be easily felt when rubbing a fingernail across them, it should be reversed when re-assembling the pump (smooth side toward the impeller) or replaced. If wear grooves can be easily felt on the cam and end cover they should be replaced. Excessive wear to any of the above parts can reduce the pumps ability to self-prime and may reduce the flow rate.

While the pump is disassembled, it is advisable to rotate the shaft a few times to determine the condition of the bearings. The shaft should rotate easily and smoothly. If the bearings grind, wobble, hang-up or make any noise, the bearings/shaft subassembly should be replaced.

To remove the shaft subassembly, first remove the bearing retaining ring from the retaining ring groove at the drive end of the bearing bore. A pair of angle-nose retaining ring pliers will be required to reach between the pulley adaptor and the pump body through the access notch on the bottom of the bearing housing. The retaining ring, when removed from its groove, will not come off the shaft subassembly but will remain loose around the shaft between the bearing and pulley adaptor. From the impeller end of the pump, press the shaft subassembly out of the bearing bore. Both bearings should come out with the shaft. However, if the forward bearing remains in the bearing bore use a 1" drift or dowel to press it out of the bore.

### ASSEMBLY

If the shaft subassembly has been removed, press the subassembly (or replacement) into the bearing bore. Align the gap of the retaining ring with the access notch in the bottom of the bearing housing and, using a pair of angle-nose retaining ring pliers, install the bearing retaining ring in the retaining ring groove. Ensure it is seated properly in its groove around the full diameter of the bearing bore.

From the impeller end of the pump, slide the ceramic portion of the seal with the O-ring towards the bearing onto the shaft. Using care not to scratch or soil the surface slide it down the shaft until it contacts the bearing. Install the seal O-ring in the O-ring groove in the seal bore. Slide the carbon portion of the seal onto the shaft with the carbon ring facing the ceramic. Push the carbon seal into the seal O-ring until the brass case is flush with the bottom of the impeller bore. Place the wearplate in the bottom of the impeller bore ensuring the anti-rotational notch is positioned at the top center of the impeller bore. Position the cam in the top of the impeller bore. Ensure the cam screw O-ring is properly positioned in its counterbore and secure the cam in place with the cam screw. Torque the cam screw to 55-60 in/lbs. With a rotary motion (in the direction of normal pump rotation) push the impeller into the impeller bore. Rotate the pump shaft to align the shaft key-way with the key-way in the impeller and slide the impeller drive key into the aligned key-ways. Using a small punch, push the key down the key-way until it is firmly bottomed at the end of the key-way. Position the end cover O-ring in its O-ring groove and secure the end cover to the pump body with the four end cover screws and lock washers. Torque the end cover screws to 75-80 in/lbs.

## EXPLODED VIEW

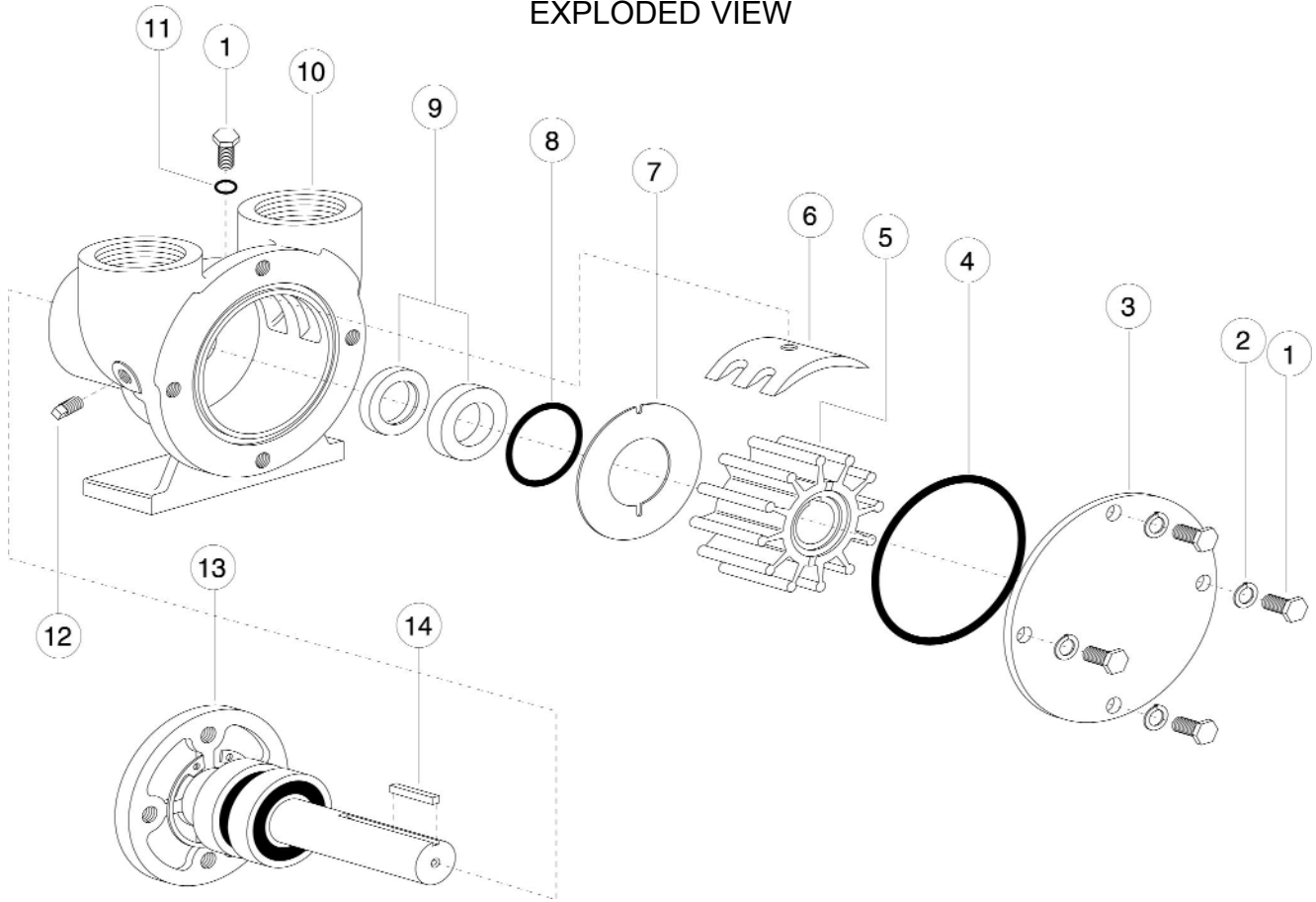

Key	Part Number	Description	Quantity
1	18753-0332	Screw, S.S. Hex Hd, 1/4-20 x 1/2	5 per kit
2		Washer, S.S. 1/4" Lock	4 per kit
3	42738-1000	End Cover	1
4	18753-0330*	O-ring for End Cover	1
5	18948-0001*	Impeller	1
6	42737-1000	Cam	1
7	4156-0000	Wearplate	1
8	18730-0000*	O-ring for seal	1
9	96080-0080*	Seal	1
10	42734-1000	Body	1
11	18753-0340*	O-ring for Cam Screw	1
12	92650-0040	Plug, 1/8" Pipe	2
13	42739-1000	Shaft Sub-Assembly	1
14	18753-0331	Key 3/16" x 3/16" x 7/8"	1

\* Parts Supplied in Service Kit

DIMENSIONAL DRAWING  
Inches (Millimetres)

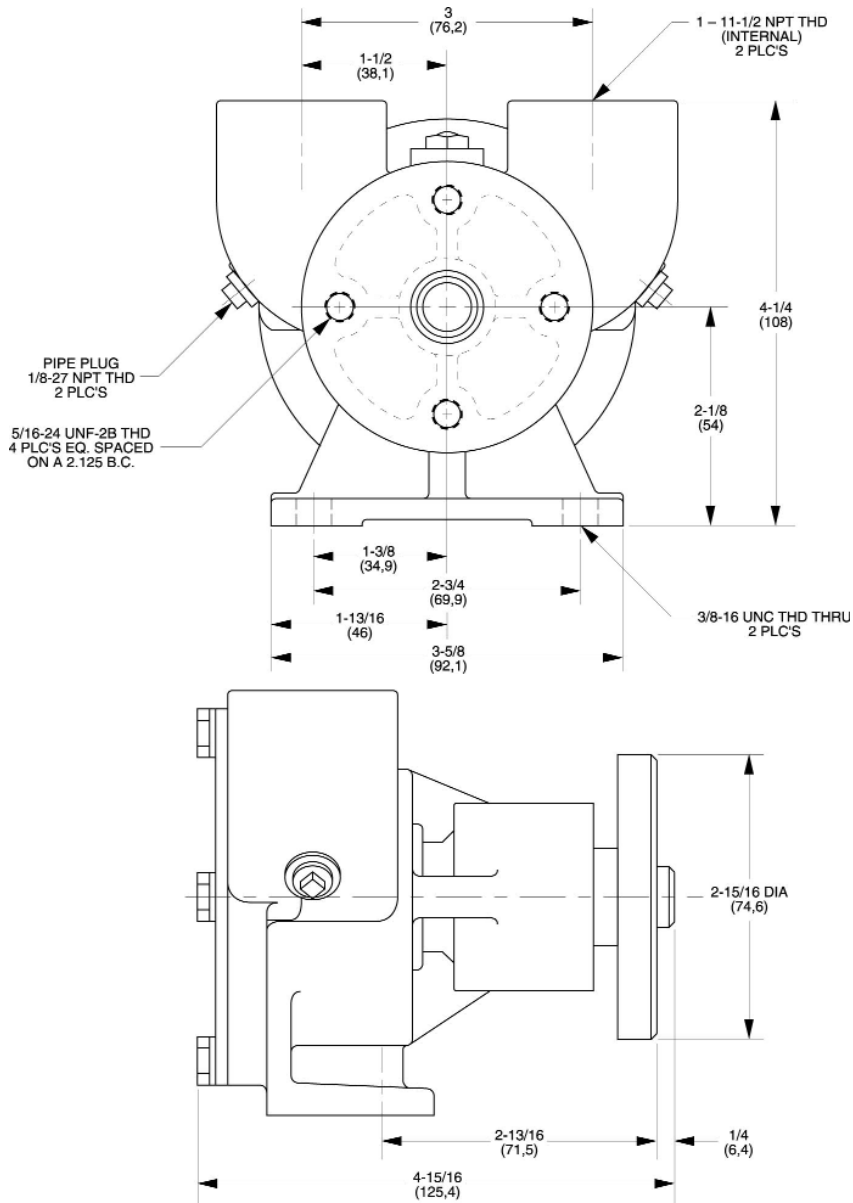

**Jabsco**



**ITT Industries**

**Jabsco**, 20 Icon, Foothill Ranch, CA 92610

Tel : +1 949 859 4945

Fax : +1 949 859 1153

**USA**

**Jabsco**, Bingley Road, Hoddesdon, Hertfordshire, EN11 0BU

Tel : +44 (0) 1992 450 145

Fax : +44 (0) 1992 467 132

**UK**

**Fluid Products Canada**, 55 Royal Road, Guelph, Ontario N1H 1T1

Tel : +1 519 821 1900

Fax : +1 519 821 5316

**CANADA**

**NHK Jabsco Co Ltd**, 3-21-10, Shin - Yokohama, Kohoku-ku, Yokohama 222

Tel : +81 (0) 45 475 8906

Fax : +81 (0) 45 475 8908

**JAPAN**

**Jabsco GmbH**, Oststraße 28, 22844 Norderstedt

Tel : +49 (0) 40 53 53 73 0

Fax : +49 (0) 40 53 53 73 11

**GERMANY**

Warranty: All products of the company are sold and all services of the company are offered subject to the company's warranty and terms and conditions of sale, copies of which will be furnished upon request.  
The information provided herein is for guidance only, it does not constitute a guarantee of the performance or specification of any individual product or component.  
©Copyright 2002 ITT Industries

43000-0544 Rev: 12/02