

### MARINE ENGINE COOLING WATER PUMP

**FEATURES**

<b>Body:</b>	Bronze, One-piece
<b>Impeller:</b>	Jabsco Neoprene
<b>Shaft:</b>	Stainless Steel
<b>Ports:</b>	1-1/4" Hose Barb
<b>Seal:</b>	Lip Type
<b>Bearings:</b>	Sealed Ball Type
<b>Shipping Weight:</b>	7 lb (3,2 kg)

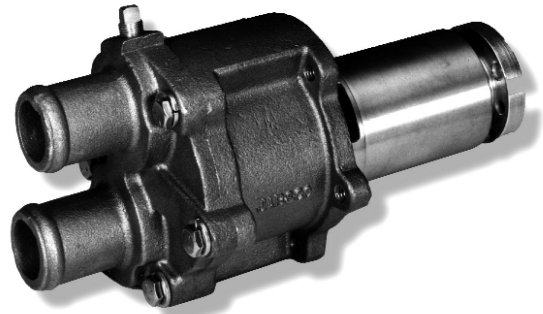

### APPLICATION

ENGINE COOLING WATER PUMP FOR MERCUISER\* ENGINES. REPLACES QUICKSILVER\* MODEL 46-72774 A32

The Jabsco pump Model 43210-0001 is a direct replacement for the Quicksilver pump Model 46-72774 A32 used on MerCruiser inboard and stern drive engines. It can be installed with either the cast iron (clamp type) mounting bracket or the stamped steel (bolt attachment type) mounting bracket. It will fit either left-hand or right-hand rotation engines and will accept all stock MerCruiser drive pulleys. The pump ports accept the standard 1-1/4" ID hoses.

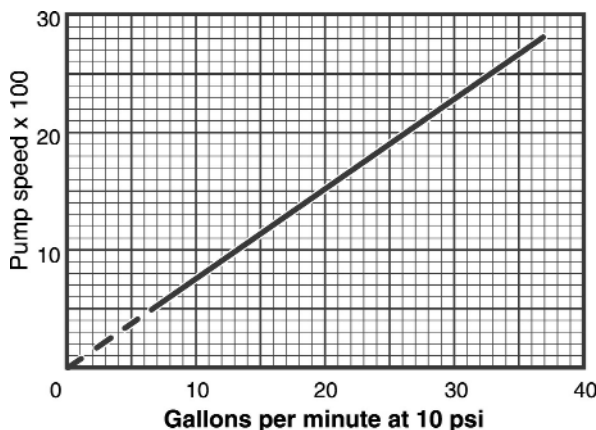

### INSTALLATION

The pump may be installed on the stamped steel or cast iron mounting brackets. To mount the pump to the stamped steel mounting bracket, use the three 5/16-18 x 3/4" hex head screws and three 5/16" lock washers included with the pump. Slide the drive end of the pump through the ID of the mounting bracket with ports pointing aft. Position the pump as illustrated in Figure 1 for left-hand rotation or Figure 2 for right-hand rotation. Attach the pump to the right-hand rotation. Attach the pump to the bracket with the three screws and lock washers positioned so they correspond to the positions indicated in Figures 1 or 2. Attach the drive pulley to the pulley adaptor flange with four 5/16-24 hex screws and lock washers (not supplied) and tighten firmly. Place the drive belt in the pulley groove. Adjust the belt tension and secure the tension adjuster bolt. Tighten both screws securing the mounting bracket to the block and retighten the four screws securing the pulley to the pulley adaptor flange.

To mount the pump with the cast iron mounting bracket, slide the bearing housing end of the pump through the ID of the bracket and align the ports and end cover as illustrated in figure 1 or 2 to comply with either right or left hand engine rotation. Attach the drive pulley to the pulley adaptor flange with four 5/16-24 hex screws and lock washers (not supplied) and tighten firmly. Slide pump forward or back in the bracket to align the pump pulley with the drive pulley and tighten bracket clamp screw. Place the drive belt in the pulley groove. Adjust the belt tension and secure the tension adjuster screw. Tighten both screws securing the mounting bracket to the block and retighten the four screws securing the pulley to the pulley adaptor flange.

If the transmission is equipped with a transmission cooler, remove the 1/8" pipe plug in the end cover and attach the trans-cooler feed line in its place.

Attach the appropriate hoses to the pump inlet and outlet ports (inlet port bottom, outlet top). Secure the hoses with quality marine grade S.S. hose clamps, two hose clamps per port are recommended.

## SERVICE

### WARNING



**Flood hazard. Before performing any service, close all waste system seacocks. Failure to do so can result in flooding which can cause loss of property and life.**

If the pump end cover is accessible, it may be possible to change the impeller without removing the pump from its mounting bracket. If there is only limited access to the pump or if more than just an impeller replacement is required, it is best to remove the pump from its mounting.

To do this, loosen (but do not remove) the four screws that secure the pulley to the pulley adaptor. Loosen (but do not remove) the two screws which secure the mounting bracket to the engine block and the belt tension arm screw. Remove the drive belt from the pulley, then remove the four pulley retention screws and the pulley. Loosen the hose clamps that secure the hoses to the pump ports and remove the two hoses from the ports.

On stern drive engines, immediately plug the inlet hose with a 1-1/4" dowel to prevent flooding. Some residual water will run out of the hoses but it should not exceed one or two gallons. If the pump is installed with a stamped steel mounting bracket, remove the three pump mounting screws and slide the pump out of the bracket. If the pump is installed with a cast iron (clamp type) mounting bracket, loosen the clamp screw and slide the pump out of the bracket. It may be necessary to very gently spread the clamp halves apart as the pump is pulled from the bracket.

### DISASSEMBLY

Remove the five screws which secure the end cover to the pump and remove the end cover and gasket. With a pair of pliers grasp the hub of the impeller and, using a rotary motion, pull it from the impeller bore. NOTE: The Jabsco replacement impeller is supplied with one thick end cover gasket and three thin body gaskets. When installing the impeller in a Jabsco pump, use the single thick gasket and discard the three thin gaskets. Remove the cam retention screw and the cam. Remove the wearplate from the bottom of the impeller bore.

With this pump it may be possible to remove the seal without removing the pump shaft. The seal is lightly pressed into an O-ring installed in the seal mounting bore and usually can be pulled out through the front of the pump using a piece of hooked wire or an O-ring removal tool. The seal O-ring can then be removed the same way. If attempting to remove the seal in this manner, use extreme care not to scratch the shaft in the area of the seal. If the shaft becomes scratched it will need to be replaced in order for the new seal to function properly.

Another method of removing the seal is to remove the shaft/bearing assembly from the body and push the seal out from the drive end of the pump. To do this, remove the pulley adaptor lock nut and alignment collar. Pull the pulley adaptor off the shaft and remove the adaptor drive key. Remove the bearing retaining ring, at the drive end of the pump and from the impeller end of the pump press the shaft/bearing subassembly out of the body. The seal can then be pushed out of the seal mounting bore by inserting a 7/8" drift or dowel through the bearing bore to push the seal out of the seal mounting bore. Remove the seal O-ring from the O-ring groove.

The O-ring located next to the bearing nearest the impeller end of the shaft serves as a water slinger and may be removed if desired. If necessary, the shaft may be pressed out of the shaft bearings. Take care to support the bearings' inner race while pressing the shaft out of the bearing. The bearing locator retaining rings may be removed from the shaft.

Clean and inspect all parts for wear. If the cam has wear grooves on it which can be easily felt with your fingernail, it should probably be replaced. If the wearplate has wear grooves it should be reversed when installed or replaced. If the pump end cover has significant wear grooves it should be replaced. Wear to any of the forementioned parts will reduce the pump's primeability. If the shaft has a wear groove where the seal rides which can be easily felt with your fingernail, the shaft should be replaced to ensure the new seal will function properly. Rotate the bearings' outer races to ensure they rotate smoothly. If they grind, wobble or hang-up, the bearings should be replaced.

### ASSEMBLY

If the bearing locator retaining rings were removed, re-install them. If the shaft bearings were removed or replaced, press the shaft into the bearings while taking care to provide support for the bearings' inner race.

Position the slinger O-ring next to the bearing nearest the impeller end of the shaft. Install the seal O-ring in the O-ring groove inside the seal mounting bore. Press the shaft/bearing subassembly into the pump body. Install the bearing retaining ring in the retaining ring groove ensuring it is properly seated all around. Install the pulley adaptor drive key in the shaft keyway and slide the pulley adaptor onto the shaft. Position the alignment collar on the threaded shaft end and secure the adaptor and collar with the lock nut. Slide the seal over the shaft with the lip pointing towards the end cover end of the pump and press it into the O-ring in the seal bore. Drop the wearplate into the impeller bore ensuring the notch in the wearplate aligns with the locator pin (centered in cam area) in the body. Apply a small amount of sealer to the top of the cam and install it in the body securing it in place with the cam screw. With a rotary motion, push the impeller into the impeller bore until the flat in the impeller insert aligns with the flat of the shaft and push the impeller completely into the pump. Position the end cover gasket on the pump. Align the end cover with the body and secure it in place with the five end cover screws and flat washers. Torque screws to 75-80 in. lbs. Re-install the pump per the Installation Instructions. When the pump is installed with the belt properly tensioned, torque the pulley adaptor lock nut to 33-36 ft. lbs.

## EXPLODED VIEW

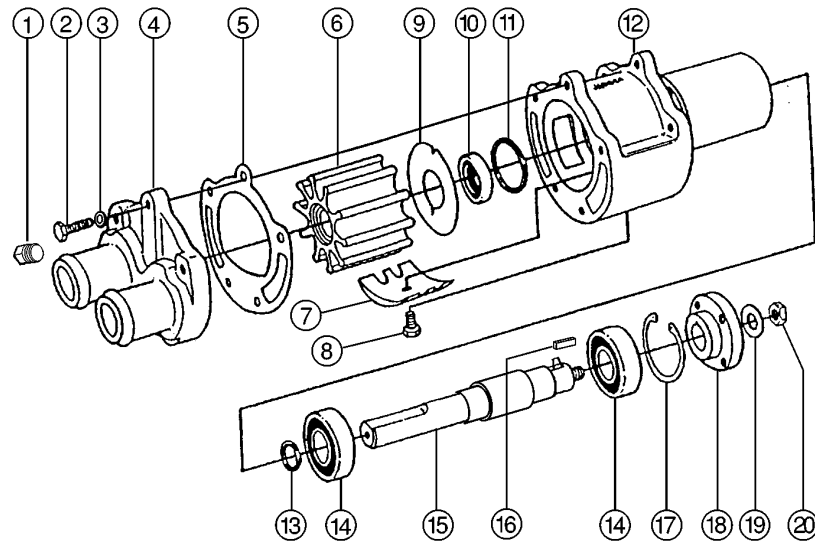

### IMPORTANT SERVICE NOTES

**NOTE 1:** If replacing a straight shaft with two retaining rings to position the bearings (used in pumps built prior to 1997), order shaft kit 43207-1000 that includes both a new style shaft with raised shoulder to position the bearings and a new style 1-5/16" long pulley adaptor.

**NOTE 2:** If replacing a short 3/4" long pulley adaptor on pumps made prior to 1997 that were fitted with a straight shaft having two retaining rings to position the bearings, order shaft kit 43207-1000 that includes both a new style shaft with raised shoulder to position the bearings and a new style 1-5/16" long pulley adaptor.

If replacing a 3/4" long pulley adaptor that is spaced away from the rear shaft bearing with a 9/16" long spacer, order part number 43204-1001, which is the new style 1-5/16" long pulley adaptor and discard the spacer.

### PARTS LIST

Key	Part. No.	Description	Qty.
1	92650-0120	Pipe Plug 1/8"	1
2	18753-0314	Screw, 1/4-20 x 7/8" S.S. Hex Head	5 Per Kit
3	"	Washer, 1/4" S.S. Flat	5 Per Kit
4	43208-1000	End Plate	1
5*	43205-1000	Gasket	1
6*	17954-0001	Impeller	1
7	43176-1000	Cam	1 Per Kit
8	"	Screw, Cam, 1/4-20 x 1/2"	1 Per Kit
9	"	Wearplate	1 Per Kit
10*	18753-0328	Seal	1
11*	92000-0540	O-Ring	1
12	43209-1000	Body	1
13	92000-0120	Slinger (O-Ring)	1
14	18753-0318	Bearings	2 Per Kit
15	43207-1001	Shaft (See NOTE 1)	1
16	18753-0591	Key	1
17	18753-0323	Retaining Ring	1
18	43204-1001	Adaptor, Pulley (See NOTE 2)	1
19	18753-0319	Alignment Collar	1 Per Kit
20	"	Lock Nut, 3/8-24	1 Per Kit
	90196-0001	Service Kit*	

\* Parts supplied in Service Kit.

# DIMENSIONAL DRAWING

Inches

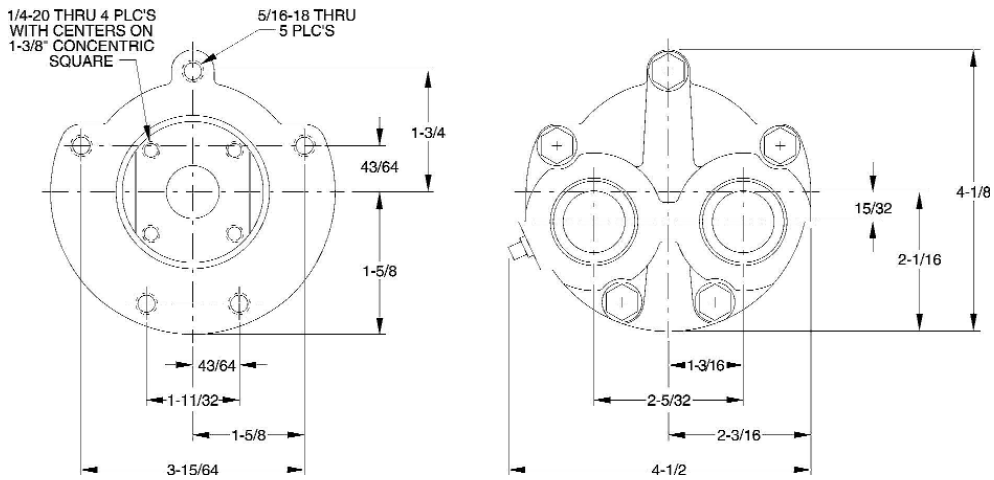
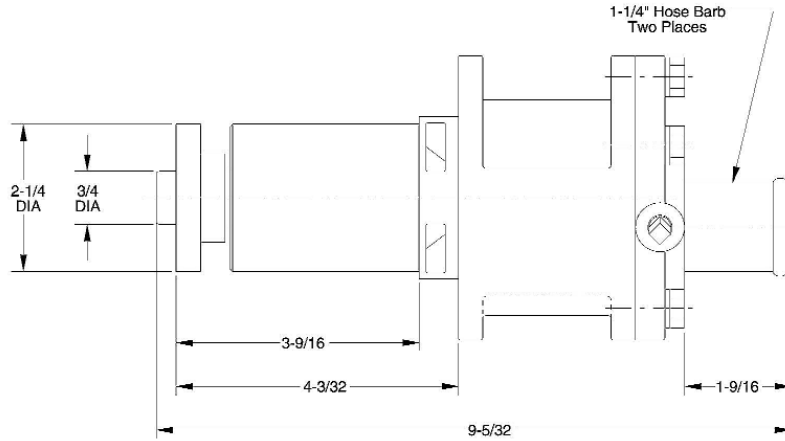

Location for  
mounting screws  
when mounting  
to stamped  
metal bracket

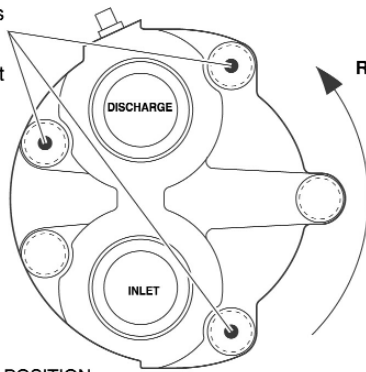

PUMP POSITION  
LEFT-HAND ROTATION **FIGURE 1**

PUMP  
ROTATION

Location for  
mounting screws  
when mounting  
to stamped  
metal bracket

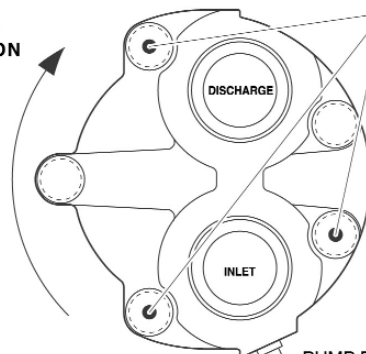

**FIGURE 2** PUMP POSITION  
RIGHT-HAND ROTATION

\*Direction of rotation as defined by MerCruiser Service Bulletin No. 81-10, 4-31-81



**Jabsco**



**ITT Industries**

**Jabsco**, 20 Icon, Foothill Ranch, CA 92610

Tel : +1 949 609 5106

Fax : +1 949 859 1254

**USA**

**Jabsco**, Bingley Road, Hoddesdon, Hertfordshire, EN11 0BU

Tel : +44 (0) 1992 450 145

Fax : +44 (0) 1992 467 132

**UK**

**Fluid Products Canada**, 55 Royal Road, Guelph, Ontario N1H 1T1

Tel : +1 519 821 1900

Fax : +1 519 821 5316

**CANADA**

**NHK Jabsco Co Ltd**, 3-21-10, Shin - Yokohama, Kohoku-ku, Yokohama 222

Tel : +81 (0) 45 475 8906

Fax : +81 (0) 45 475 8908

**JAPAN**

**Jabsco GmbH**, Oststraße 28, 22844 Norderstedt

Tel : +49 (0) 40 53 53 73 0

Fax : +49 (0) 40 53 53 73 11

**GERMANY**

Warranty: All products of the company are sold and all services of the company are offered subject to the company's warranty and terms and conditions of sale, copies of which will be furnished upon request. The information provided herein is for guidance only, it does not constitute a guarantee of the performance or specification of any individual product or component.

©Copyright 2003 ITT Industries

43000-0682 Rev: 02/03