

ELECTROMAGNETIC CLUTCH PUMPS - DESIGN FEATURES



50080 SERIES & 50200 SERIES

Body	Bronze
Impeller	Jabsco neoprene or nitrile compound
Shaft Seal	Lip type (50200 Series Mechanical Carbon/Ceramic)
Bearing	Ball
Shaft	Stainless steel 316 S31 to BS970
Wearplate	Replaceable
Pulley	Anodised Aluminium
Ports	1" BSP (50200 Series 1 1/2" BSP) to BS21 (DIN2999)
Weight	5 kg (50200 Series 9.5 kg)



50220 SERIES

Body	Bronze
Impeller	Jabsco neoprene or nitrile compound
Shaft Seal	Mechanical carbon ceramic
Bearing	Ball
Shaft	Stainless steel 316 to BS970
Wearplate	Replaceable
Pulley	Anodised Aluminium
Bearing Housing	Cast iron painted protective primer
Ports	1 1/2" Flange
Weight	11.2 kg

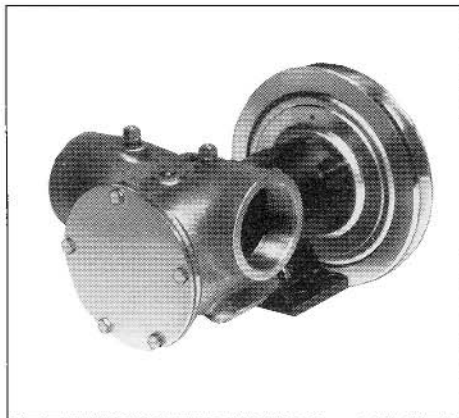

50270 SERIES

Body	Bronze
Impeller	Jabsco neoprene or nitrile compound
Shaft Seal	Mechanical carbon ceramic
Bearing	Ball
Shaft	Stainless steel 316 to BS970
Wearplate	Replaceable
Pulley	Painted cast iron
Bearing Housing	Cast iron painted protective primer
Ports	2" BSP to BS21 (DIN2999) Available with 2" Flange
Weight	12.2 kg



29870 SERIES

Body	Bronze
Impeller	Jabsco neoprene
Shaft Seal	Mechanical carbon ceramic
Bearing	Ball
Shaft	Stainless steel 316 to BS970
Wearplate	Replaceable
Pulley	Painted cast iron
Bearing Housing	Cast iron painted protective primer
Ports	2 1/2" BSP to BS21 (DIN2999) and Flange
Other	Can be purchased without the Clutch
Weight	18 kg

SIZE 270

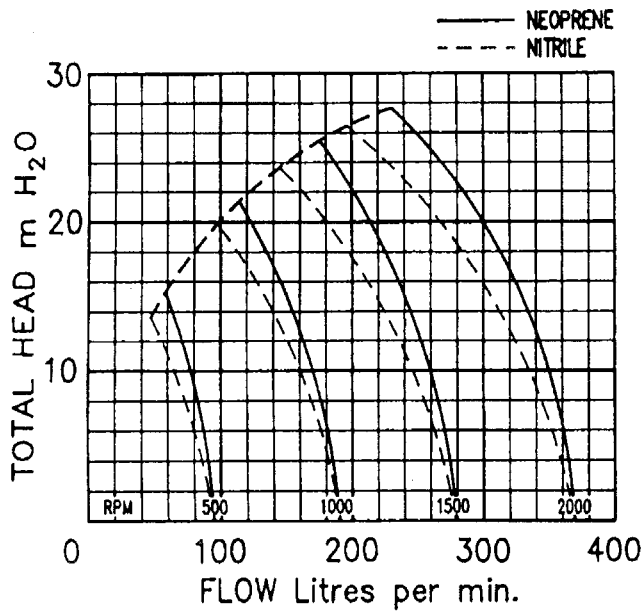

Performance Note Power (watt) figures shown are minimum recommended at pumpshaft.

Total manometric head	500 rpm	750 rpm	1000 rpm	1500 rpm	1750 rpm	2000 rpm
	550 watt	750 watt	1500 watt	1800 watt	2200 watt	3000 watt
m/H2O	L/m	L/m	L/m	L/m	L/m	L/m
3	91	137	183	275	321	368
5	87	133	179	271	317	363
9	81	126	172	263	309	355
12	72	117	162	253	298	343
15	60	105	150	239	284	329
18		90	134	223	267	311
21			116	203	246	290
24				180	223	265
27					196	238
Suction Bore	51mm	51mm	51mm	51mm	51mm	63.5mm
Temp 0C	Metres	Metres	Metres	Metres	Metres	Metres
20	7.4	7.4	6.9	4.8	1.9	2.3
30	7.2	7.2	6.7	4.6	1.7	2.1
40	6.8	6.8	6.3	4.2	1.3	1.7
50	6.2	6.2	5.7	3.6	0.7	1.1

Maximum recommended suction head in mH₂O at water temperature 20°C

SIZE 500

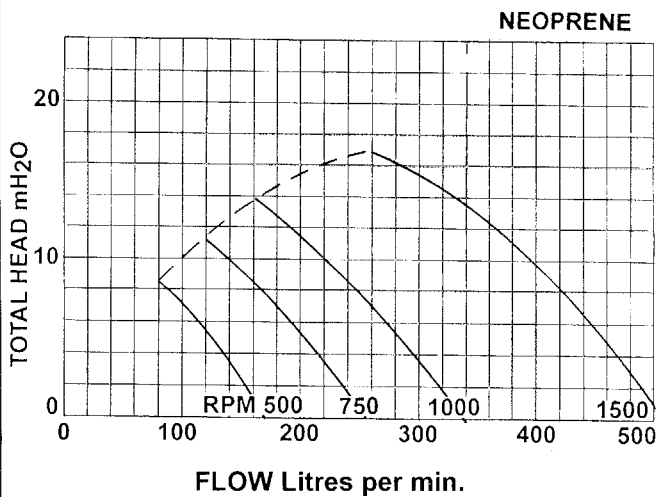

Performance Note Power (watt) figures shown are minimum recommended at pumpshaft.

Total manometric head	500 rpm	750 rpm	1000 rpm	1500 rpm
	1500 watt	2200 watt	2200 watt	4000 watt
5	132	220	303	463
9	79	165	246	402
12	40	127	210	361
15	-	60	145	308
18	-	-	-	250
20	-	-	-	194
Suction Bore	63.5mm	63.5mm	63.5mm	63.5mm
Temp	Metres	Metres	Metres	Metres
20°C	7.5	7.0	6.0	3.5
30°C	7.3	6.8	5.8	3.3
40°C	7.0	6.5	5.5	2.8
50°C	6.5	6.0	5.0	2.3

Maximum recommended suction head in mH₂O at water temperature 20°C

Pump Selection Tables and Graphs show approximate performance for new pumps with neoprene impeller pumping water (specific gravity 1.00) at 20°C, but note that performance can be affected if water temperature and suction head are higher than shown in above table. If in doubt consult your local Jabsco distributor or factory for application assistance.

* Minimum nominal recommended bore. Note: Suction Head = Vertical Suction Height + Pipe Losses.

EXPLODED VIEW

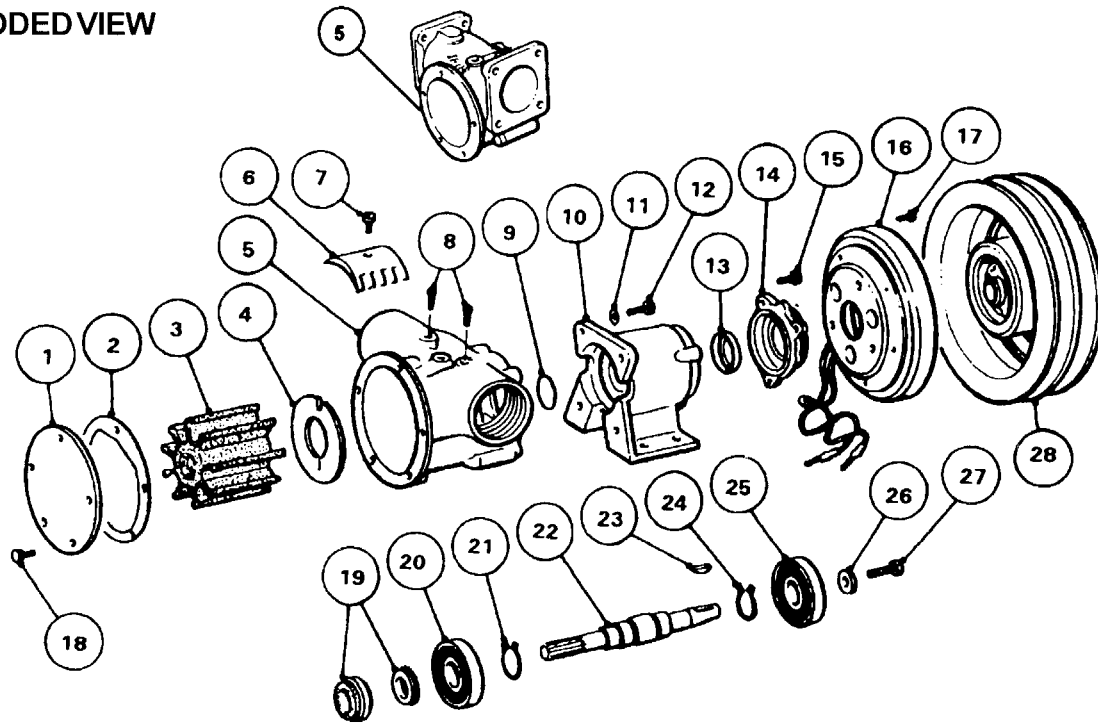

PARTSLIST

KEY	DESCRIPTION	QTY	50220 - SERIES	50270 -0 SERIES	50270-2 SERIES
1	Endcover	1	9336	9336	9336
2	Gasket*	1	816	816	816
3	Neoprene Impeller*	1	17935-0001	21676-0001 or 17936-0001	21676-0001 or 17936-0001
	Nitrile Impeller **	1	836-0003	21676-0003 or 6760-0003	21676-0003 or 6760-0003
4	Wear plate	1	2574	2574	2574
5	Body	1	10634-02 (Flange)	10494-01 (Flange)	50274-2000 (BSP)
6	Cam	1	834	6988	6988
7	Cam Screw	1	SP1005-04	SP1005-04	SP1005-04
8	Pipe Plug	1	SP2650-07	SP2650-07	SP2650-07
9	Slinger	1	X4020-324A	X4020-324A	X4020-324A
10	Bearing Housing	1	50273-0000	50273-0000	50273-0000
11	Washer	4	SP1602-13	SP1602-13	X3081-101C
12	Bolt	4	SP1095-28	SP1095-28	X3001-209C
13	Inner Bearing Seal	1	SP2701-54	SP2701-54	SP2701-54
14	Clutch Adaptor	1	52201-1000	52201-1000	52201-1000
15	Bolt	3	X3001-180F	X3001-180F	X3001-180F
16	Field Coil (12v)	1	SP2300-0063FC	SP2300-0063FC	SP2300-0063FC
	Field Coil (24v)	1	SP2300-0064FC	SP2300-0064FC	SP2300-0064FC
17	Screw***	3	X3001-176F	X3001-176F	X3001-176F
18	Endcover Screws *	5	SP1095-0640	SP1095-0640	X3001-176F
19	Seal Assembly *	1	21849	21849	21849
20	Bearing	1	SP2601-0458	SP2601-0458	SP2601-0458
21	Retaining Ring	1	Y5026-08	Y5026-08	Y5026-08
22	Shaft	1	50227-0000	50277-0000	50277-0000
23	Key	1	SP1401-10	SP1401-10	SP1401-10
24	Retaining Ring	1	Y5026-08	Y5026-08	Y5026-08
25	Bearing	1	SP2601-0458	SP2601-0458	SP2601-0458
26	Washer***	1	Supplied with Clutch	Supplied with Clutch	Supplied with Clutch
27	Screw***	1	Supplied with Clutch	Supplied with Clutch	Supplied with Clutch
28	Pulley (2A)	1	SP2300-0061RA	SP2300-0061RA	SP2300-0061RA
	Pulley (1B)	1	SP2300-0063RA	SP2300-0063RA	SP2300-0063RA

*** Supplied with Key 28

50220 - SERIES

Service Kit SK407-0011
Service Kit SK407-0003

50270 - SERIES

Service Kit SK408-0011
Service Kit SK408-0013

All Service Kits contain parts marked*, plus ** in place of Neoprene Impeller.

Port Adaptors (Optional Extra)

Series	Kit No.	Description
50220	K1-01	2" I/D Hose
	K1-200	1-1/2" BSP
	K1	1-1/2" NPT

Port Adaptors (Optional Extra)

Series	Kit No.	Description
50270-0	K2-01	2-1/2" I/D Hose
	K2-200	2" BSP
	K2	2" NPT

Refer to Operating Instructions on page 17.

Inspect all parts for wear or damage and replace if necessary.

50270 SERIES

DIS-ASSEMBLY

1. Remove end cover screws, end cover and gasket.
2. Remove impeller.
3. Loosen cam screw and remove cam.
4. Remove wearplate.
5. Remove bolt from end of shaft. Screw $\frac{5}{8}$ UNC screw into the hub of the pulley assembly in order to draw the pulley from the pump shaft.
6. Remove 3 bolts holding the field coil onto the housing adaptor.
7. Remove field coil.
8. Remove 3 fixing bolts and rear adaptor housing from bearing housing.
9. Remove bolts from bearing housing to body and remove body from bearing housing.
10. Remove seal assembly from body.
11. Press shaft on impeller drive end to remove shaft and bearings from bearing housing.
12. Press shaft out of bearings supporting inner race of bearing. Remove retaining rings from shaft if necessary.
13. Remove inner bearing seal if it needs replacing.

ASSEMBLY

1. Press new seal into bearing housing with lip facing away from bearing bore.
2. Fit retaining rings onto shaft and press on bearings.
3. Grease seal area of shaft, push bearings and shaft into bearing housing by pressing on outer race of bearings.
4. Fit adaptor housing to bearing housing, secure with 3 bolts.
5. Fit field coil to adaptor using 3 bolts. Check that centre bore of field coil fits over boss on adaptor.
6. Wipe pump shaft to remove any particles and check location of key. Slide pulley assembly onto shaft, lining with key and secure with retaining bolt.
7. Place slinger on shaft.
8. Fit pump body to bearing housing securing with 4 bolts.
9. Take new seal seat (cup rubber and seal seat), lightly grease the outside edge of cup rubber and press into cavity in pump body with ceramic facing towards impeller bore.
10. Slide mechanical seal sub assembly over shaft until it engages against ceramic face of stationary seal.
11. Fit wearplate.
12. Coat cam screw threads, top side and back of cam, with non setting jointing compound and fit into body, securing with the cam screws.
13. Lightly grease impeller bore and fit impeller.
14. Fit end cover and gasket, and secure with screws.

50200 SERIES

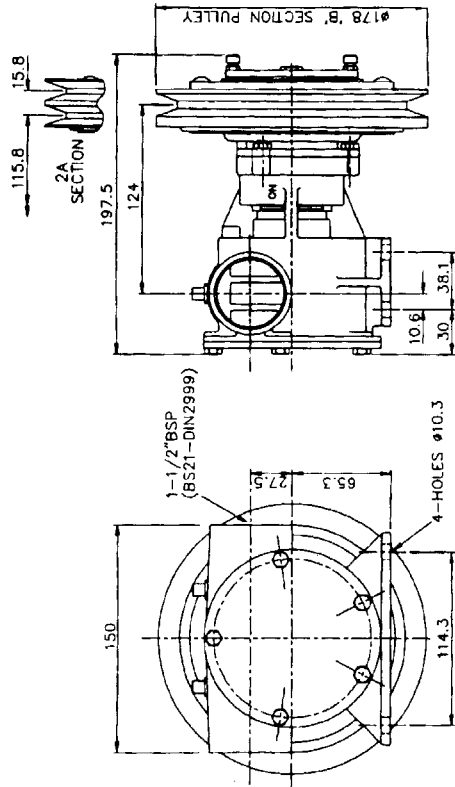

50080 SERIES

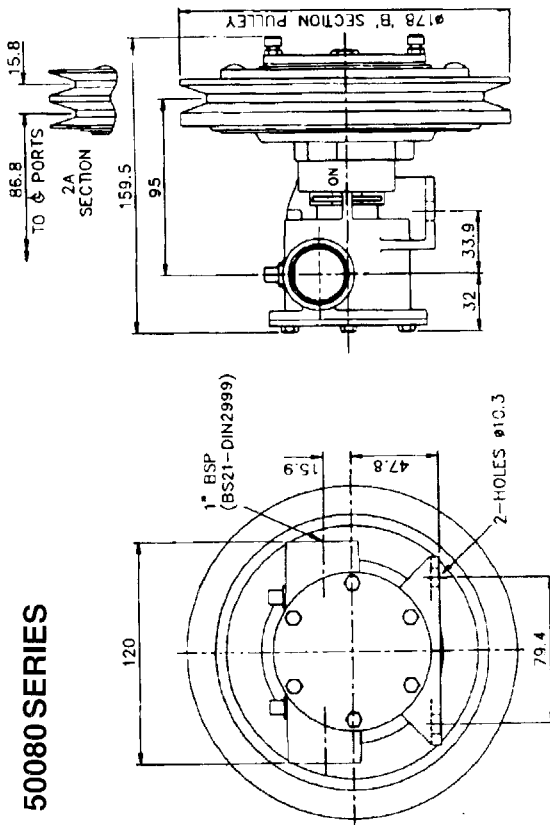

50270 SERIES

PORT TAPPING (TYP)
4-HOLES 3/8"-16 UNC 2B
EQUALLY SPACED ON
Ø90.47 ±0.2 PC.

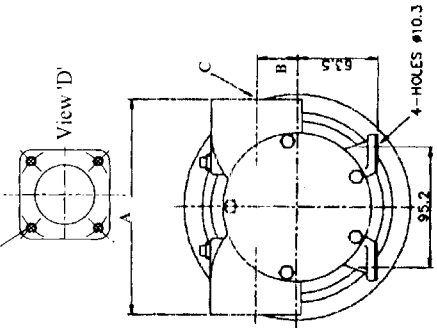

50220 SERIES (Flanged Ports)

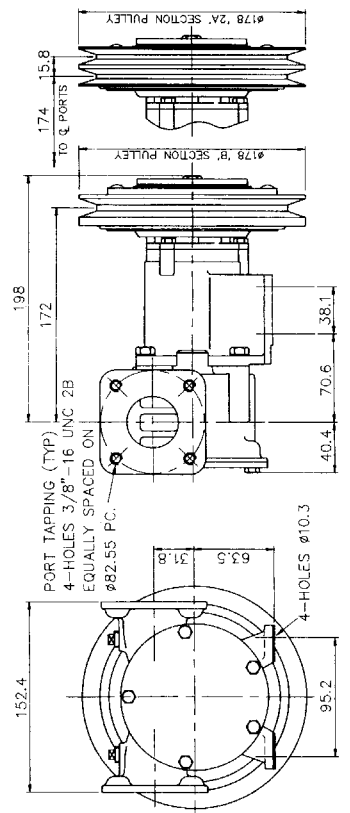

	A	B	C
50270 - 'O' Series	152.4	41.3	See View 'D'
50270 - '2' Series	170	32	2" BSP (BS21 - DIN2999)

PUMP MAY BE MOUNTED in any position. When installed vertically motor must be above the pump.

THE ROTATION OF THE PUMP SHAFT determines the location of the pump inlet/outlet ports: refer to installation drawing.

BEFORE INSTALLING rotate pump shaft and impeller in the direction of the required operation.

ALL PUMP PIPEWORK must be adequately supported to avoid stress on pump and pump components and consequential leakage.

BELT DRIVEN PUMPS excessive drive belt tension will cause rapid belt wear and may result in premature bearing failure. It should be possible to deflect a correctly tensioned belt between pulleys about 16mm per metre of span by applying finger pressure. Ideally, the contact area should be about 120° but not less than 90°.

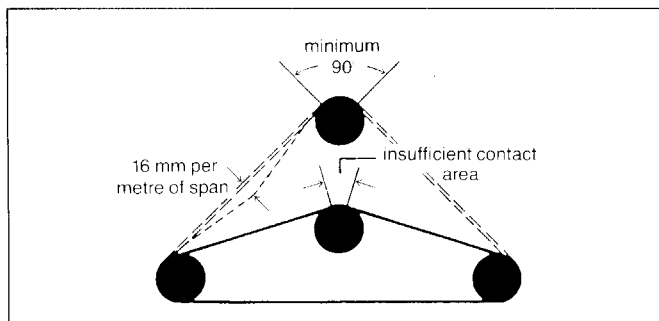

OPERATION

Pump should not be operated above its published performance without referring to distributor.

D.C. CLUTCHES

Inadequate supply voltage at DC terminals (not less than 20% below rated voltage at full load) due to partly discharged battery or voltage loss through long or small size electric wire may cause fuses to blow or pump starting problems. If fuse fails repeatedly, identify and solve the fault. (DO NOT under any circumstances fit a heavier fuse or bridge fuse terminals). Connect black wire or negative (-) battery terminal.

Red wire should run via a suitably rated switch and fuse to a positive (+) battery terminal. The pump should be installed where it will always remain dry. Ensure battery capacity is adequate for ALL electrical equipment (pumps, radio, TV, refrigerator, navigational instruments). Observe installation instructions of instruments likely to be affected by close proximity of a magnetic field such as navigational instruments.

WIRING DIAGRAM

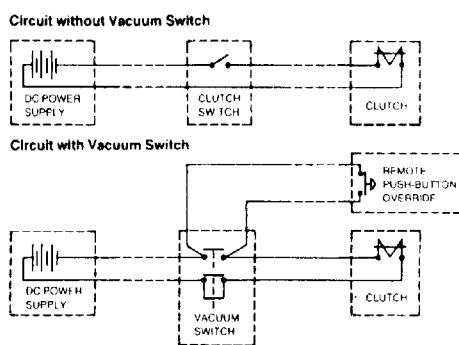

Electrical installation must take into account the minimum wire size recommended.

12v Clutches need 5 amp fuse with 1.5mm² wiring.
24v Clutches need 2.5 amp fuse with 1.0mm² wiring.

TEMPERATURE: Operating range

Neoprene Impellers	4-80°C
Oil Resistant Impellers	10-90°C

PUMPS: are dry self-priming i.e. do not require to be filled with liquid start up.

RUNNING DRY: Unit depends on liquid pumped for lubrication. A dry running period of up to 30 seconds is generally a safe length of time. If pump has not been primed after 30 seconds, stop and check for air leaks in pipework, and impeller, seal or gasket damage.

SAFETY ADVICE

Ensure that all moving parts are adequately guarded to prevent accidental contact. Leakage from mechanical seal or gland could cause hazard. If liquids being pumped are toxic or corrosive, use of a drip tray is recommended.

DO NOT USE for Petrol, Toluene, Benzene or light fraction petroleum products such as solvent, thinners or other liquids with flashpoint below 37°C.

FREEZING Temperatures - do not permit liquid to freeze in pump body. Drain pump by loosening end cover.

IT IS A REQUIREMENT OF COSHH(1988) REGULATIONS THAT THE MANUFACTURER'S INSTRUCTIONS IN THE HANDLING OF HAZARDOUS SUBSTANCES MUST BE OBSERVED AT ALL TIMES.

To conform with the Health and Safety and COSHH Regulations, ITT Jabsco will require that any pump or part of a pump that is returned to this company for repair or examination, or for any reason whatsoever, will be accompanied by a letter stating what the pump/part has been pumping.

If the liquid or product is hazardous or in any way dangerous, this must be stated and the chemical make-up of it must be stated in detail.

Unless this procedure is observed then the unit will not be accepted on our company premises. The only exception to this rule is if the pump returned is new and unused.