

### EXPLODED VIEW

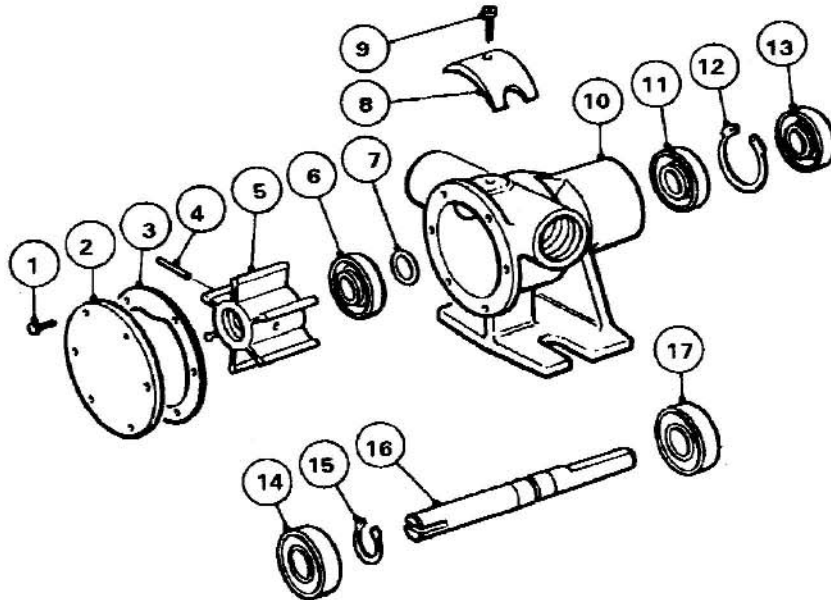

### PARTS LIST MODEL 52020-2001

Key	Description	Qty	Part No
1	Endcover Screw *	6	X3001-095F
2	Endcover	1	3992
3	Gasket *	1	2995-0030
4	Impeller Screw *	1	SP1010-06
5	Impeller *	1	653-0001B
6	Seal *	1	SP2701-1006
7	"O" Ring	1	X4020-210A
8	Cam	1	2907-0001
9	Cam Screw	1	SP1002-09
10	Body	1	52024-2000
11	Bearing Seal	1	SP2701-1006
12	Retaining Ring	1	SP1701-4438
13	Bearing Seal	1	SP2701-0501
14	Bearing	1	SP2601-0457
15	Retaining Ring	1	SP1701-4440
16	Shaft	1	52027-0000
17	Bearing	1	SP2601-0457

Service Kit No SK405-0101 Contains Parts marked\*

### INSTALLATION DRAWING

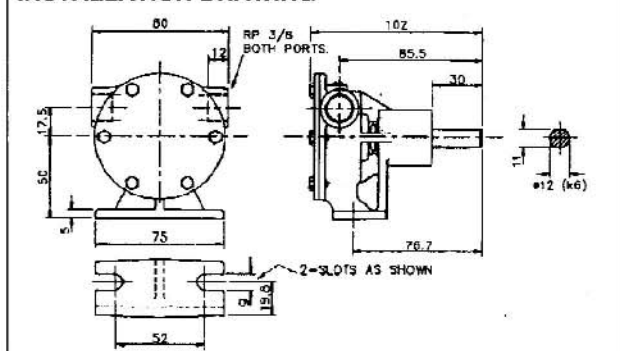

### SERVICE INSTRUCTIONS

**Dis-Assembly** Inspect all parts for wear or damage and replace if necessary

1. Remove endcover screws, endcover and gasket.
2. Remove impeller.
3. Remove wearplate.
4. Loosen cam screw and remove cam, (clean off old jointing compound).
5. Remove seal and 'O' ring with hooked wire.
6. Insert screwdriver between OD of outer bearing seal and pump bore and pry out seal.
7. Remove bearing to body retaining ring.
8. Press on impeller drive end of shaft to remove shaft and bearing assembly. Heating outside of body will ease dis-assembly.
9. Lever bearings apart and remove from shaft. Use extreme care not to mar body bore. Insert screwdriver between OD of inner bearing seal and pump body, and pry out the seal.

### Assembly

1. Lubricate inner bearing seal with grease and press into body bearing seal bore with lip facing away from bearing bore.
2. Push bearings onto shaft and up against retaining ring.
3. Position slinger in body drain area. Insert slotted end of shaft through bearing bore and guide slinger over shaft until bearings contact body.
4. Press on bearing outer race, install bearings into bore. Heating outside of body at bearing area will ease assembly.
5. Install bearing to body retaining ring in body groove.
6. Lubricate outer bearing seal with grease and press into bearing bore until it is flush with the body.
7. Install 'O' ring in groove in seal bore.
8. Lubricate OD and lip seal, then push into place using care not to damage or cut seal lip. (Lip faces impeller bore).
9. Install wearplate in body bore, aligning dimple in wearplate with slot in cam.
10. Coat cam screw threads, and top of cam with a non setting jointing compound. Install in body.
11. Thread impeller drive screw into impeller, and lightly grease impeller bore and start impeller into bore with a rotary motion until impeller drive screw engages with slot in shaft.