

Hy~Line LH3 Size Rotary Lobe Pumps - Data Sheet

Hy~Line LH3 size rotary lobe pumps are available in two models, LH32 and LH34 to complement the highly successful, Hy~Line pump series. They offer efficient, clean and safe movement of a wide variety of liquids for smaller processes, OEM equipment and pilot plant applications within the food, dairy, beverage, personal care, pharmaceutical, biotech and general industrial markets. See **Fig. 1** for Model overview

Size	LH32	LH34
Displacement - L/100 revs (Gall/100 revs)	3.5 (0.92)	7.0 (1.85)
Standard Port Size - mm (inch)	19 (¾")	25 (1")
Enlarged Port Size - mm (inch)	25 (1")	38 (1½")
Max. diff. Press. - bar (psi) High Pressure	15 (215)	8 (115)
Max. diff. Press. - bar (psi) High Efficiency	5 (71)	-
Maximum Speed - rpm	1500	1500
Maximum Flow - L/min (Gall/min)	52 (13)	105 (27)
All references to Gallons are US Gallons		

Fig. 1 - Hy~Line LH3 Size Models Overview

Materials

Product Contact Stainless Steel

Liquid contact metal parts are made from low-carbon stainless steel, US designation 316L (European designation 1.4404). This grade of material has less than 0.03% carbon. The primary benefits are much lower carbide concentration than normal 316 (1.4401) stainless steel where for example the ports are welded, combined with greatly reduced risk of carbon "pull-out" with demineralised water.

Bearing Housing

Like other Hy~Line pumps, the round smooth external contours offer free draining of wash down solutions, with minimal areas where dust or dirt can collect. LH3 size bearing housing are cast in LM31 grade aluminium alloy.

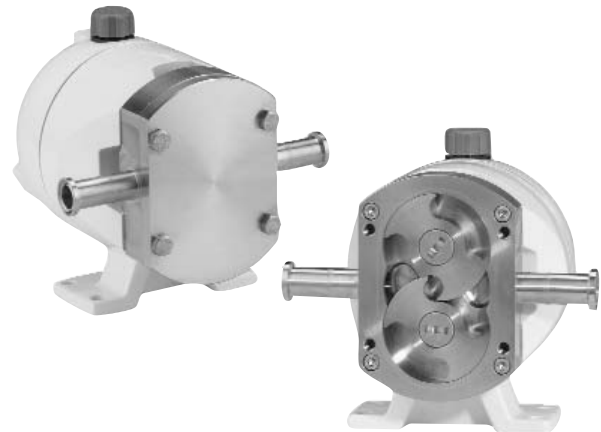

The electrostatically applied epoxy polyester powder coating gives a resilient smooth and chemically resistant surface.

Seals & Elastomers

The seal design is based around Jabsco market leading EHEDG conforming Ultra-Hygienic Ultima & 55 Series mechanical seals. Seal combination materials include Carbon, Stainless Steel and Silicon Carbide, all of which are to US FDA requirements, see **Fig. 2**. The seal location in the fluid flow path minimizes product retention risks, whilst making in-place cleaning more efficient. Located in the rear face of each rotor, L-cups are used with the rotary seal seats, while O rings (Nitrile and PTFE) and Quad rings (EPDM & Viton) are employed on the stationary seal seats, see **Fig. 3**.

Design

Jabsco have manufactured lobe pumps for more than 20 years. Including the World's smallest truly hygienic lobe pump. 55 Series was the first to meet EHEDG standards, it is now is used around the globe on thousands on leading edge, quality critical applications. The Hy~Line LH3 Size pumps utilize this valuable experience, as well as many of the features in a design that offers excellent performance and value. See **Fig. 4** for the main design features.

Fig. 2 - Mechanical Seal Face Materials

Rotary / Stationary	Single Seal	Single Flushed
Carbon / Stainless Steel	✓	✓
Carbon / Silicon Carbide	✓	✓
Silicon Carbide / Silicon Carbide	✓	✓

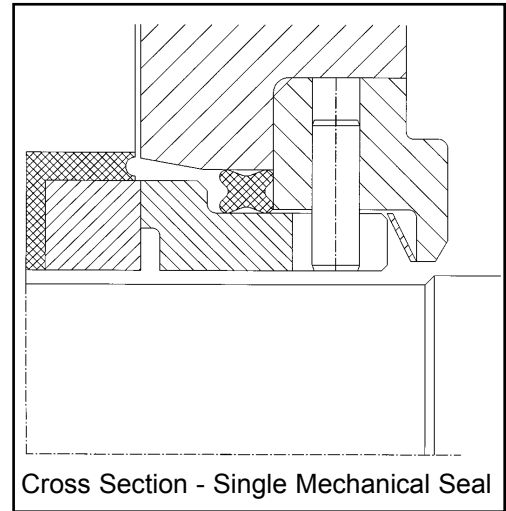

Fig. 3 - Product Contact Elastomers

Elastomer Material	Endcover	Seal Seat		Flush
		Rotary	Stationary	
Nitrile (FDA & 3A)	O ring	L-Cup	O ring	Lip Seal
EPDM (FDA)	O ring	L-Cup	Quad ring	–
Viton (FDA)	O ring	L-Cup	Quad ring	–
PTFE	O ring	L-Cup	O ring	–

Fig. 4 - Features and Benefits of Hy~Line LH3 Size Pumps

FEATURE	BENEFIT	Product Handling	Application Flexibility	Cleaning	Reliability	Maintenance	Critical Applications	Regulation Compliance
316L (1.4404) Stainless Steel	Product compatibility, Biopharm regulations			✓			✓	✓
FDA & 3A Conformity	Complies to industry regulations	✓					✓	✓
Heavy duty construction	Suitable for continuous use		✓		✓			
Pressures to 15 bar (LH32 code 9)	Reliability, Viscous products, Safety factor		✓		✓			
Flush end cover & rotor retainer	Reliable operation & effective CIP cleaning			✓	✓			
Scimitar rotors	Efficiency, Gentle handling & Easy timing	✓	✓			✓		
Welded ports	Effective cleaning			✓				
Front loading & balanced mechanical seals	Cleaning, product flow and access	✓		✓	✓	✓		
Single and Single flushed mechanical seals	Reliability on a wide range of applications	✓	✓		✓			
Choice of seal face materials & elastomers	Reliable & flexible to suit most products	✓	✓		✓		✓	
Product Temperatures to 140°C / 284°F	Steam SIP and high temperature duties	✓		✓	✓		✓	
Air gap between pump chamber & gearbox	Quick inspection, less contamination risk	✓		✓	✓			✓
Round Shape & Epoxy polyester coated	Easy cleaning of exterior			✓				
Taper roller bearings, with individual set-up	Strong, reliable, simple design				✓	✓		
One shim position (behind rotors)	Easy maintenance				✓	✓		
Fixed, cast in foot on bearing housing	Heavy duty				✓			
Simple shaft timing, 'two-flat' rotor drive.	Less mistakes, 'Easy maintenance				✓	✓		
Variable speed, bi-directional operation	Easy to install, flexible operation	✓	✓		✓			
OPTIONS								
'Self drain' pump chamber (needs vertical ports)	CIP fluid & product recovery, reliable SIP	✓	✓	✓			✓	✓
High efficiency rotors (LH32 code 8 only)	Less 'slip' on low viscosity products		✓					
Thermal endcover jackets	Handles temperature critical liquids	✓	✓					
Endcover relief valve	Protects pump from over pressure		✓		✓			
Alternative gear cover for side mounting	Flexibility of installation		✓					

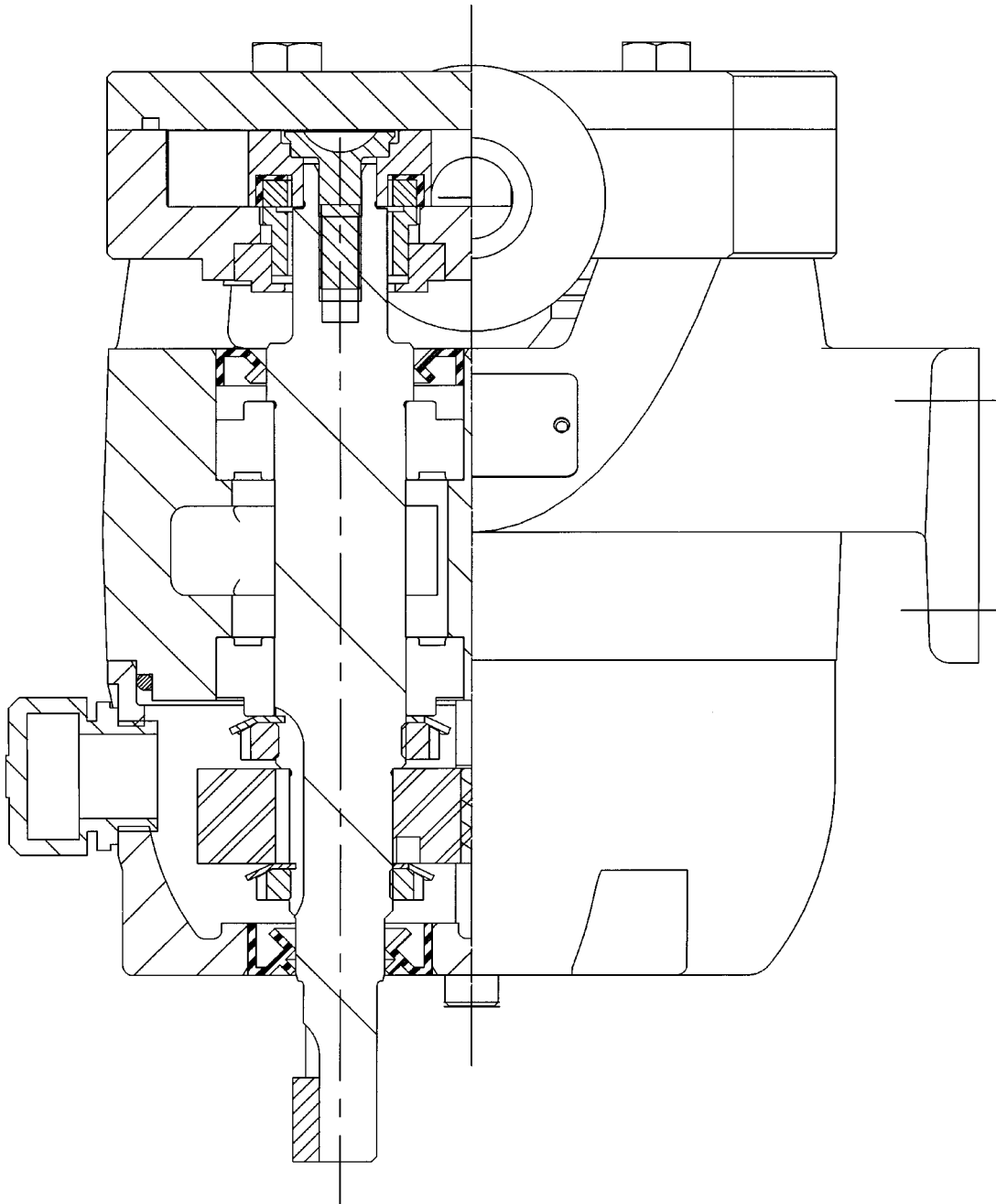
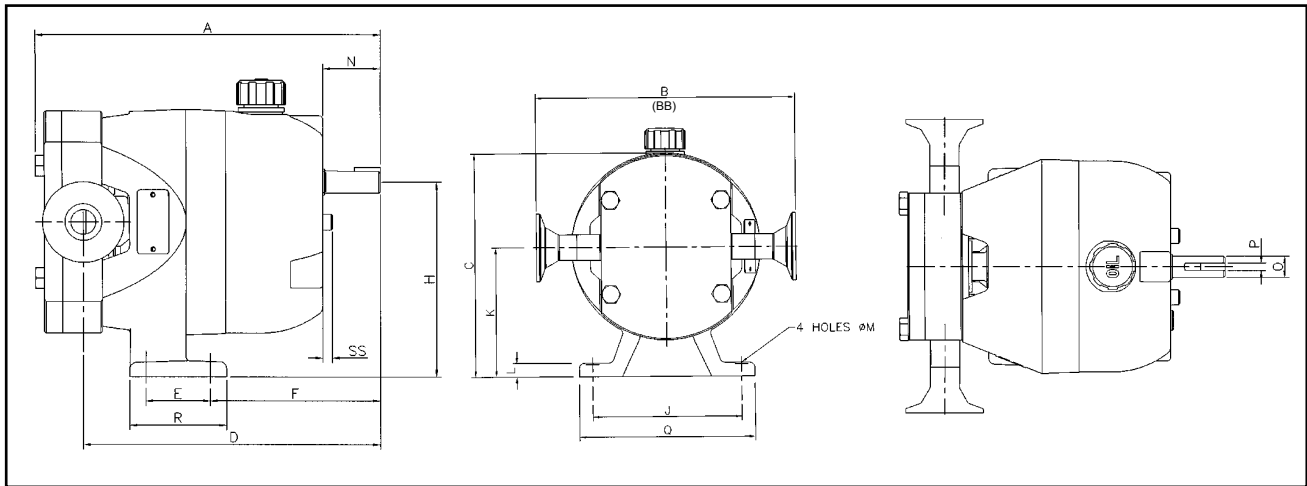

Fig. 5 - Cross Section of LH32 Pump

Fig. 6 - Dimensions



PUMP	A		B*		BB**		C		D		E		F		G		H		J		
	mm	inch	mm	inch	mm	inch	mm	inch	mm	inch	mm	inch	mm	inch	mm	inch	mm	inch	mm	inch	
32	213	8.4	192	7.6	192	7.6	166	6.5	184	7.2	40	1.6	105	4.1	N/A	121	4.8	110	4.3		
34	229	9.0	192	7.6	192	7.6	166	6.5	188	7.4	40	1.6	105	4.1	N/A	121	4.8	110	4.3		
PUMP	K		L		M		N		O		P		Q		R		SS		Weight		
	mm	inch	mm	inch	mm	inch	mm	inch	mm	inch	mm	inch	mm	inch	mm	inch	mm	inch	kg	lbs	
32	96	3.8	10	0.4	10	0.4	36	1.4	14	0.6	5	0.2	130	5.1	60	2.4	6	0.2	8	17.6	
34	96	3.8	10	0.4	10	0.4	36	1.4	14	0.6	5	0.2	130	5.1	60	2.4	6	0.2	10	22.0	

EXCEPTIONS					
B* LH340 Standard Sizes	B		BB** LH34L Enlarged Ports	BB	
	mm	inch		mm	inch
All connections (except those below)	192	7.6	All connections (except those below)	192	7.6
1"/25mm Tri-clamp (code 1)	175	6.9	1.5" BSPT (code 2)	202	8.0
25mm DIN11851 (code 6)	201	7.9			

Fig. 7 - Availability of Connection Types

n/a: Not available		Port Type	Tri-Clamp	BSPT	IDF/ISS	RJT	3A ACME	DIN 11851	SMS	NPT
Pump Prefix	Port Size	Port Code	1	2	3	4	5	6	7	9
LH320	19 (¾")	Standard	✓	✓	✓	n/a	n/a	✓	n/a	✓
LH32L	25 (1")	Enlarged	✓	✓	✓	✓	✓	✓	✓	✓
LH340	25 (1")	Standard	*✓	✓	✓	✓	✓	*✓	✓	✓
LH34L	38 (1½")	Enlarged	✓	**✓	✓	✓	✓	✓	✓	✓

Jabsco



ITT Industries

USA

Jabsco
20 Icon
Foothill Ranch
CA 92610

Tel : +1 949 859 4945
Fax : +1 949 859 1153

UK

Jabsco
Bingley Road
Hoddesdon
Hertfordshire, EN11 0BU

Tel : +44 (0) 1992 450 145
Fax : +44 (0) 1992 467 132

GERMANY

Jabsco GmbH
Oststraße 28
22844 Norderstedt

Tel : +49 (0) 40 53 53 73 0
Fax : +49 (0) 40 53 53 73 11