

Wastewater

10S-CIA Series



Features

- Handles Liquids and solid waste materials up to 2" diameter
- Cast iron pump housing with protective epoxy coating for corrosion resistance
- Oil-filled motor housing for lifetime lubrication and rapid heat dissipation
- Stainless steel screws, bolts, handle and switch guard
- Mechanical seals (stainless steel spring, nitrile parts, carbon and ceramic faces)
- Thermal overload protection
- Integral snap-action float switch — Automatic operation has 11" to 14" "On" level range and 5" to 8" "Off" level range
- Piggyback mechanical float switch — Automatic operation has 15" to 17" "On" level range and 8" to 10" "Off" level range
- PSC type motor with upper and lower ball bearings on 10S-CIA-SFS
- Split-phase type motor on 10S-CIA-RFS



Dimensional Outline

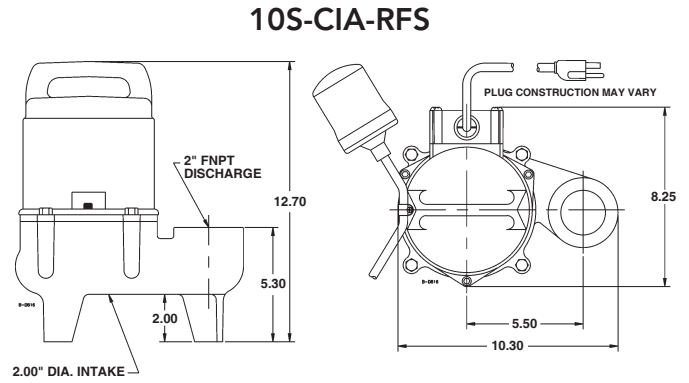
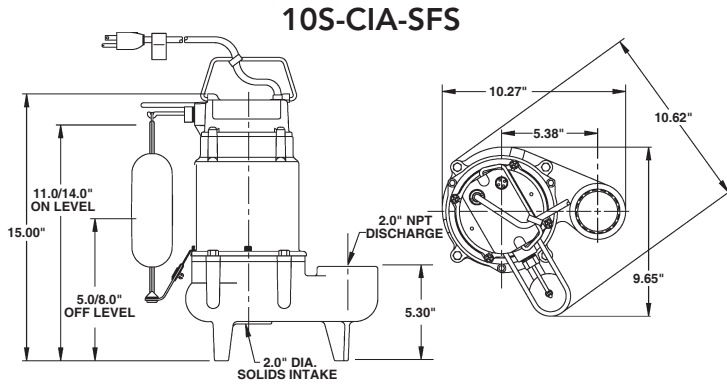

* Note: Mechanical Float Switch to be installed by customer. Installation at 3.5" tether length float switch will activate pump at 15"-17" on level and 8"-10" off level.

Specifications

Model No.	Item No.	Listings	HP	Volts/Hz	Solids Size (Dia. in.)	Running Amps/Watts	Performance (GPM@Head)			Shut Off		Pwr. Cord (ft.)	Weight (lbs.)	Dimensions (H x L x W)
							5'	10'	15'	Feet	PSI			
10S-CIA-SFS	511550	UL/CSA	1/2	115	2	9.2/1086	110	85	45	20	8.7	10	46	15 x 10.3 x 9.65
10S-CIA-SFS	511555	UL/CSA	1/2	115	2	9.2/1086	110	85	45	20	8.7	25	46	15 x 10.3 x 9.65
10S-CIA-SFS	511565	UL/CSA	1/2	230	2	4.6/1086	110	85	45	20	8.7	25	47	15 x 10.3 x 9.65
10S-CIA-RFS	511500	UL/CSA	1/2	115	2	12/1000	110	85	45	20	8.7	15	45	12.7 x 10.3 x 8.25

Construction

Motor Housing	Epoxy Coated Cast Iron
Impeller Material	Glass Filled Nylon
Impeller Type	Vortex
Volute	Epoxy Coated Cast Iron
Power Cord	16 - 3 SJTW
Mechanical Shaft Seal	Nitrile parts with carbon and ceramic faces
Fasteners	Stainless steel
Shaft	Steel
Bearings	Upper & lower ball bearings

Performance Data

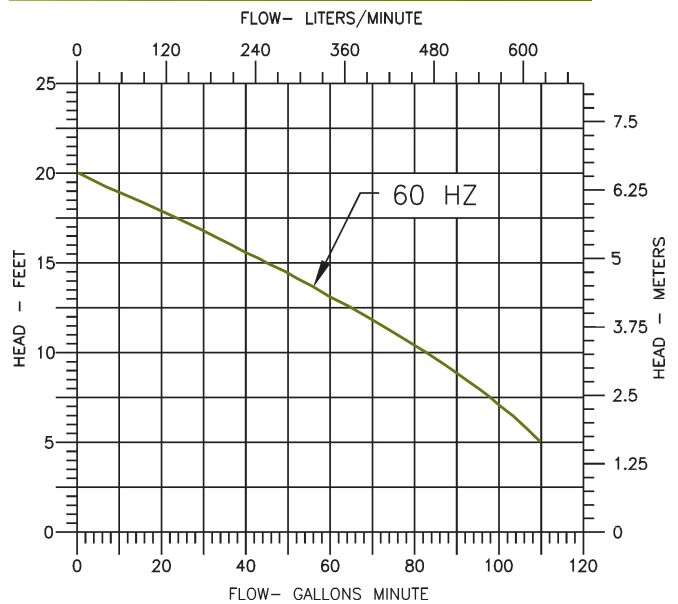

P.O. Box 12010
Oklahoma City, OK 73157-2010
Phone: 1.800.701.7894
Fax: 1.800.678.7867
www.LittleGiantPump.com



INTRODUCTION

This instruction sheet provides you with the information required to safely own and operate your product. Retain these instructions for future reference.

The product you have purchased is of the highest quality workmanship and material, and has been engineered to give you long and reliable service. This product has been carefully tested, inspected, and packaged to ensure safe delivery and operation. Please examine your item(s) carefully to ensure that no damage occurred during shipment. If damage has occurred, please contact the place of purchase. They will assist you in replacement or repair, if required.

READ THESE INSTRUCTIONS CAREFULLY BEFORE ATTEMPTING TO INSTALL, OPERATE, OR SERVICE YOUR PRODUCT. KNOW THE PRODUCT'S APPLICATION, LIMITATIONS, AND POTENTIAL HAZARDS. PROTECT YOURSELF AND OTHERS BY OBSERVING ALL SAFETY INFORMATION. FAILURE TO COMPLY WITH THESE INSTRUCTIONS COULD RESULT IN PERSONAL INJURY AND/OR PROPERTY DAMAGE!

DESCRIPTION

The pump you have purchased is a submersible effluent pump for use in basins or lift stations and suitable for pumping sewage, effluent, wastewater and other non-explosive, non-corrosive liquids. The 10S Series sewage ejector pumps have a 2" spherical solids handling capability. The 10E Series sewage effluent pumps have a 3/4" spherical solids handling capability.

SAFETY GUIDELINES



Do not use to pump flammable or explosive fluids such as gasoline, fuel oil, kerosene, etc. Do not use in explosive atmospheres. Use the pump only with liquids compatible with pump component materials.

Do not handle pump with wet hands or when standing on a wet or damp surface, or in water.

Do not use power cord for lifting the pump.

This pump is supplied with a grounding conductor and/or grounding-type attachment plug. To reduce the risk of electric shock, be certain that it is connected to a properly grounded grounding-type receptacle.

The National Electric Code requires a ground fault circuit interrupter (GFCI) be installed in the branch circuit supplying fountain equipment, pools, etc.

In any installation where property damage and/or personal injury might result from an inoperative or leaking pump due to power outages, discharge line blockage, or any other reason, a backup system(s) and/or alarm should be used.

Support pump and piping when assembling and when installed, failure to do so may cause piping to break, pump to fail, motor bearing failures, etc.

This pump's motor housing is filled with a dielectric oil for motor heat transfer and lifetime lubrication of the bearings. This oil is non-toxic to aquatic life; however, suffocation can occur if oil is left on the water surface. If oil escapes the motor housing, it can be

removed from the surface quickly by placing newspapers on the water surface to soak up the oil.

The pump motor is equipped with an automatic resetting thermal protector and may restart unexpectedly. Protector tripping is an indication of motor overloading as a result of excessively high or low voltage, inadequate wiring, incorrect motor connections or a defective motor or pump.

ELECTRICAL CONNECTIONS



1. Check the pump label for proper voltage required. Do not connect to voltage other than that shown.
2. If pump is supplied with a 3-prong electrical plug, the third prong is to ground the pump to prevent possible electrical shock hazard. **DO NOT REMOVE** the third prong from the plug. A separate branch circuit is recommended. Do not use an extension cord. Do not cut plug from the cord. If the plug is cut or the cord is shortened, then this action will void the warranty.
3. If the cord is equipped with stripped lead wires, such as on 230V models, be sure that the lead wires are connected to a power source correctly. The green/yellow wire is the ground, the other two are live.
4. Check local electrical and building codes before installation. The installation must be in accordance with their regulations as well as the most recent National Electrical Code (NEC).
5. To conform to the National Electrical Code all pumps must be wired with 14 AWG or larger wire. For runs to 250', 14 AWG wire is sufficient. For longer runs, consult a qualified electrician or the factory.

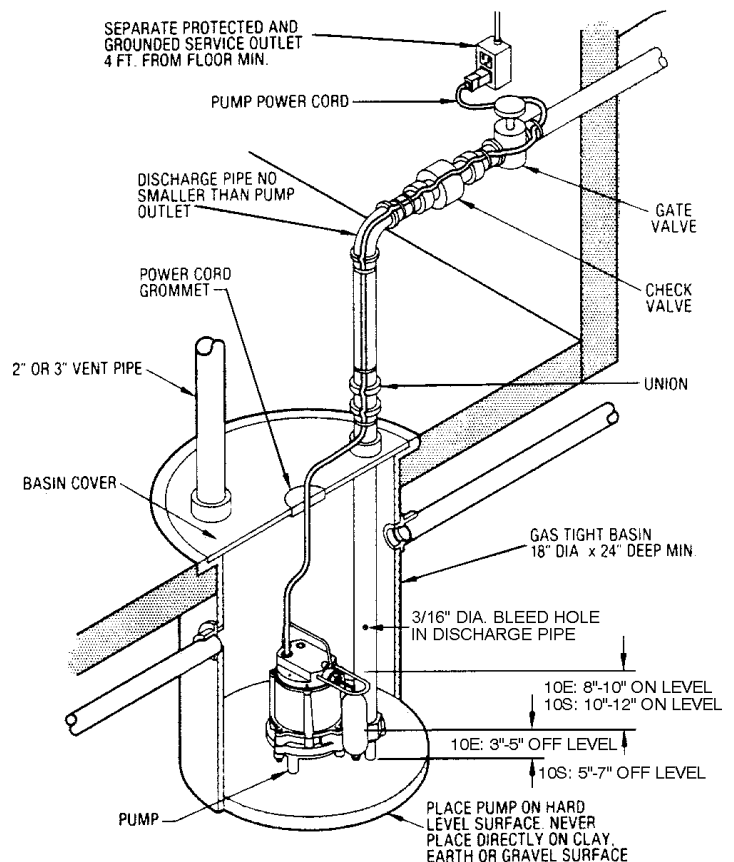

Figure 1

6. Connect or wire the pump to its own circuit with no other outlets or equipment in the circuit line. Fuses and circuit breaker should be of ample capacity in the electrical circuit.
7. Do not modify the power cord except to shorten it to fit into a control panel. Any splice between the pump and the control panel must be made within a junction box and mounted outside of the basin, and comply with the National Electrical Code.

INSTALLATION AND OPERATION



1. Install the pump in a suitable, gas-tight basin that is at least 18" in diameter and 24" deep, and vented in accordance with local plumbing codes.
2. Place the pump on a hard, level surface. Never place the pump directly on clay, earth, or gravel surfaces.
3. Use a check valve in the discharge line to prevent backflow of liquid into the basin. **NOTE:** The 10E series uses a 1-1/2" female NPT discharge; the 10S series uses 2" female NPT discharge. The check valve should be a free-flow valve that will easily pass solids. Drill a 3/16" hole in the discharge pipe approximately 1"-2" above the pump discharge connection and below check valve to prevent air locking the pump.
CAUTION: For best performance of check valves when handling solids, install the valve horizontally or at an angle of no more than 45°. Do not install the check valve vertically, as solids may settle in valve and prevent opening on start-up.
4. Do not restrict the intake side of the pump. This can damage the seal and can starve the pump. To reduce flow, place a valve on the discharge side of the pump or, if flexible vinyl tubing is used, a clamp on the tubing.
5. Do not let the pump operate dry. It is cooled by pumping fluid. You may damage the seal and the motor may fail if the pump is allowed to operate dry.
6. If the pump will be idle for an extended period, follow the cleaning instructions in the MAINTENANCE section. Do not let the pump freeze in the wintertime. This can cause cracking or distortion that will damage or destroy the pump.

TESTING



NOTE: These pumps are equipped with a float-operated mechanical switch.

1. When the pump is installed in a basin with a sealed cover, switch operation cannot be observed. The basin cover usually will have a spare hole that is plugged with a rubber plug. Remove this plug to observe switch operation.
2. Plug the power cord into a grounded receptacle with voltage consistent with pump voltage as indicated on pump nameplate.
3. Run water into the basin until the pump starts.
4. Be sure gate valve in discharge line is open.
5. Allow the pump to operate through several on-off cycles.
6. If pump does not operate properly, consult the TROUBLESHOOTING table. If the problem still cannot be located, consult your pump dealer or take the pump to a Little Giant authorized service center.

MAINTENANCE



WARNING: DISCONNECT THE PUMP FROM THE POWER SOURCE BEFORE ATTEMPTING TO SERVICE OR REMOVE ANY COMPONENT!

CAUTION: DO NOT remove impeller. This requires special tools and is to be done only by an authorized service center. Do not remove motor housing cover. Warranty is void if motor housing cover, impeller, or seals have been removed. Any repair on motor must be done by an authorized Little Giant service center.

CAUTION; DO NOT remove the three socket head cap screws (1). The motor section on your pump is permanently lubricated with dielectric oil and sealed at the factory. Removal of these screws by anyone other than an authorized Little Giant service center will break the seal and void the warranty.

Periodic cleaning of the pump will prolong its life and efficiency. Refer to Figure 2 and the following steps to clean your pump:

1. Disconnect the pump from its power source.
2. 10E series: Remove the five screws (24) that hold the screen base (22) and base plate (23) to the volute/plate.
10S series: Remove the four hex bolts (19) that hold volute (21) to the plate (23). Remove the volute.
3. Clean the impeller. Do not use strong solvents.
4. Be sure impeller turns freely after cleaning.
5. Inspect the power cord to ensure that it is in good condition and has no nicks or cuts.

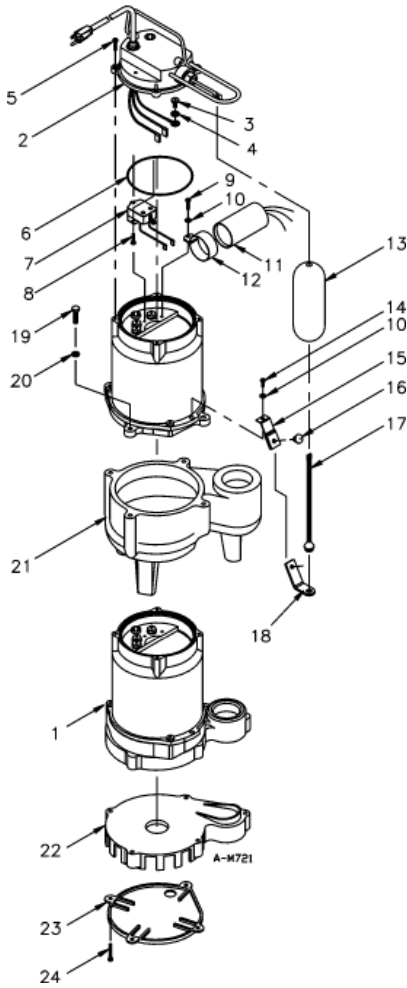

Figure 2

REPLACEMENT PARTS			MODEL/CATALOG NO.				
ITEM NO.	PART NO.	DESCRIPTION	10E-CIA-SFS 511350	10E-CIA-SFS 511355	10S-CIA-SFS 511550	10S-CIA-SFS 511555	10S-CIA-SFS 511565
2	110352	Cover assembly, 10ft, (115v)	1	--	1	--	--
2	110353	Cover assembly, 25ft, (115v)	--	1	--	1	--
2	110354	Cover assembly, 25ft, (230v)	--	--	--	--	1
5	909022	Screw/washer, 10-24 x 5/8	4	4	4	4	4
6	928002	Seal ring, nitrile	1	1	1	1	1
7	950250	Switch	1	1	1	1	1
8	902431	Screw, 8-18 x 1/2	2	2	2	2	2
11	950507	Capacitor assembly, 10-SFS	1	1	1	1	1
12	110101	Bracket, capacitor	1	1	1	1	1
13	106362	Float	1	1	1	1	1
14	902516	Screw, tapping, 10-24 x 1/2	1	1	1	1	1
15	110100	Retainer, float rod strap	1	1	1	1	1
16	929451	Push-in fastener	1	1	1	1	1
17	106381	Rod, float	1	1	1	1	1
18	106367	Strap, float	1	1	1	1	1
20	921103	Washer, lock	--	--	4	4	4
21	111415	Volute	--	--	1	1	1
22	109420	Base, screen	1	1	--	--	--
23	109153	Plate, base	1	1	--	--	--
24	909024	Screw/washer	5	5	--	--	--

TROUBLESHOOTING

PROBLEM	PROBABLE CAUSES	CORRECTIVE ACTIONS
Pump does not turn on.	Pump not plugged in.	Plug in pump.
	Circuit breaker shutoff or fuse removed.	Turn on circuit breaker or replace fuse.
	Accumulation of trash on float.	Clean float.
	Float obstruction.	Check float path and provide clearance.
	Defective switch.	Have pump serviced by authorized service center
	Defective motor.	Have pump serviced by authorized service center.
Pump will not shut off.	Float or float rod obstruction.	Check float and float rod path and provide clearance.
	Pump is air locked.	Shut power off for approximately 1 minute, then restart. Repeat several times to clear air from pump.
	Liquid inflow matches pump capacity.	Larger pump required.
	Defective switch.	Disconnect switch, check with ohmmeter. Open-infinite resistance closed zero.
Pump runs but does not discharge liquid.	Check valve installed backwards.	Check flow indicating arrow on check valve body to ensure it is installed properly.
	Check valve stuck or plugged.	Remove check valve and inspect for proper operation.
	Lift too high for pump.	Check rating table.
	Inlet to impeller plugged.	Pull pump and clean.
	Pump is air locked.	(See corrective action above.)
Pump does not deliver rated capacity.	Lift too high for pump.	Check rated pump performance.
	Low voltage, speed too slow.	Check for proper supply voltage to make certain it corresponds to nameplate voltage.
	Impeller or discharge pipe is clogged.	Pull pump and clean. Check pipe for scale or corrosion.
	Impeller wear due to abrasives.	Replace worn impeller.
Pump cycles continually.	No check valve in long discharge pipe allowing liquid to drain back into basin.	Install a check valve in discharge line.
	Check valve leaking.	Inspect check valve for correct operation.
	Basin too small for inflow.	Install larger basin.

LIMITED WARRANTY

Little Giant #6E, #8E, #9#, #10E, #14EH, and #16EH Series Submersible Effluent Pumps are recommended for use in sumps, basins or lift stations and suitable for pumping basement drainage water, effluent, wastewater and other non-explosive, non-corrosive, non-abrasive liquids not above 140°F with up to 3/4" spherical solids (1/2" on 6E models) handling ability. (Not to be used for sewage water except to pump septic tank effluent.)

Little Giant #9S, #10S, #14S and #16S series Submersible Sewage Ejector Pumps are recommended for use in sumps, basins or lift stations and suitable for pumping sewage, effluent, wastewater and other non-explosive, non-corrosive, non-abrasive liquids not above 140°F with up to 2" spherical solids handling ability. Each of the above noted Little Giant products is guaranteed to be in perfect condition when it leaves our factory. During the time periods and subject to the conditions hereinafter set forth, Little Giant Pump Company, subsidiary of Franklin Electric Company, Inc., will repair or replace to the original user or consumer any portion of your new Little Giant product which proves defective due to materials or workmanship of Little Giant. Contact your nearest Authorized Little Giant dealer for warranty service. At all times Little Giant shall have and possess the sole right and option to determine whether to repair or replace defective equipment, parts, or components, damage due to lightning or conditions beyond the control of Little Giant is NOT covered by this warranty.

WARRANTY PERIOD

PUMPS: 24 months from date of purchase or 30 months from date of manufacture, whichever occurs first.

LABOR, ETC. COSTS: Little Giant shall in no event be responsible or liable for the cost of field labor or other charges incurred by any customer in removing and/or affixing any Little Giant product, part or component thereof.

This warranty will not apply:

1. to defects or malfunctions resulting from failure to properly install, operate, or maintain the unit in accordance with printed instructions provided
2. to failures resulting from abuse, accident or negligence
3. to normal maintenance services and the parts used in connection with such service
4. to units which are not installed in accordance with applicable local codes, ordinances and good trade practices
5. unit is used for purposes other than for what it was designed and manufactured
6. if pump exposed to but not limited to the following: sand, gravel, cement, grease, plaster, mud, tar, hydrocarbons, or hydrocarbon derivatives (oil, gasoline, solvents, etc.) or other abrasive or corrosive substances.
7. if pump has been used for continuous pumping of suitable liquids above 140°F
8. if power cord has been cut or spliced
9. if pump has been dismantled by customer. (Dealer only can dismantle pump for field service.)

RETURN OR REPLACED COMPONENTS: Any item to be replaced under the Warranty must be returned to Little Giant at Oklahoma City, Oklahoma, or such other place as Little Giant may designate, freight prepaid.

PRODUCT IMPROVEMENTS: Little Giant reserves the right to change or improve its products or any portions thereof without being obligated to provide such a change or improvement for units sold and/or shipped to such change or improvement.

DISCLAIMER: Any oral statements about the product made by the seller, the manufacturer, the representatives or any other parties, do not constitute warranties, shall not be relied upon by the user, and are not part of the contract for sale. Seller's and manufacturer's only obligation, and buyer's only remedy, shall be the replacement and/or repair by the manufacturer of the product as described above. Neither seller nor the manufacturer shall be liable for any injury, loss or damage, direct, incidental or consequential (including, but not limited to, incidental or consequential damages for lost profits, lost sales, injury to person or property, or any other incidental or consequential loss), arising out of the use or the inability to use the product, and the user agrees that no other remedy shall be available to it. Before using, the user shall determine the suitability of the product for his intended use, and user assumes all risk and liability whatsoever in connection therewith. The warranty and remedy described in this limited warranty is an EXCLUSIVE warranty and remedy and is IN LIEU OF any other warranty or remedy, expressed or implied, which other warranties and remedies are hereby expressly EXCLUDED, including, but not limited to any implied warranty of MERCHANTABILITY OR FITNESS FOR A PARTICULAR PURPOSE. Some States do not allow the exclusion or limitation of incidental or consequential damages, so the above limitation or exclusion may not apply to you. This warranty gives you specific legal rights, and you may also have other rights which vary from state to state.

In the absence of other suitable proof of the purchase date, the effective date of this warranty will be based upon the date of manufacture plus two years. Direct all notices, etc. to: Service Department, Little Giant Pump Company, 3810 N. Tulsa, Oklahoma City, OK 73112.

DETERMINATION OF UNIT DATE OF MANUFACTURE: (9-87) month and year stamped on pump and/or serial number on pump nameplate coded to indicate year of manufacture.

For parts or repair, please contact1-888-572-9933
For technical assistance, please contact1-888-956-0000

Pour des parties ou la réparation,
entrez s'il vous plaît en contact1-888-572-9933
Pour l'aide technique, entrez s'il vous plaît en contact1-888-956-0000

Para partes o la reparación,
por favor póngase en contacto1-888-572-9933
Para la ayuda técnica, por favor póngase en contacto1-888-956-0000

www.LittleGiantPump.com
CustomerService-WTS@fele.com