

OWNERS MANUAL

READ INSTRUCTIONS CAREFULLY BEFORE ATTEMPTING TO INSTALL, OPERATE OR SERVICE THE LITTLE GIANT PUMP. PROTECT YOURSELF AND OTHERS BY OBSERVING ALL SAFETY INFORMATION AND ADDITIONAL INSTRUCTIONS INCLUDED WITH THIS EQUIPMENT. FAILURE TO COMPLY WITH INSTRUCTIONS COULD RESULT IN PERSONAL INJURY AND/OR PROPERTY DAMAGE! RETAIN INSTRUCTIONS FOR FUTURE REFERENCE.

- ASSEMBLY
- INSTRUCTIONS
- OPERATIONS
- REPAIR
- SAFETY



World's Largest Manufacturer of Centrifugal Pumps

PUMP SPECIFICATIONS

VOLTS	AMPS	WATTS	HP	GALLONS PER HOUR						
				1 FT.	3 FT.	5 FT.	10 FT.	15 FT.	20 FT.	26 FT.
115	5	380	1/6	1200	1170	1100	1000	840	520	0

CAPACITY SIZING INFORMATION

The 1200 GPH performance was obtained through a 1 inch I.D. tube, with friction losses neglected. Using a 5/8" garden hose 60 foot long reduces this performance to approximately 300 gallons per hour due to friction losses in the garden hose. If your area frequently has heavy rainfalls, (1-2 inches per hour), it may be necessary to use 1 inch tubing. This should be available in most pool supply stores. The number of gallons of water that your pool will collect in a rainfall of one inch per hour can be computed as follows:

Cover overall length (FT) x cover overall Width (FT) x .6234=Gallons Per Hour
(Note: This is cover dimension, and not pool dimension.)

Example: A pool cover which is 16' by 32' would collect:
16 x 32 .6234=319 Gallons in 1 hour, in 1 inch per hour rain.

A pool cover which is 20' by 40' would collect:
20 x 40 x .6234=499 Gallons in 1 hour, in 1 inch per hour rain

INSTALLATION

Little Giant pumps are carefully packaged, inspected and tested to insure safe operation. When you receive your pump, examine it carefully to be certain that there are no broken or damaged parts, which may have occurred in shipment. If damage has occurred, (See Replacement Parts Section), make notation and notify the firm from which you purchased the unit. They will assist you in replacement or repair.

1. Be certain electrical outlet to be used meets the requirements of the National Electrical code, as well as local electrical codes, including grounding, and GFCI protection. Also verify that outlet is properly sized and located for this pump. Your installation may require a certified electrician, or plumber. See Electrical Connections Section.
2. If necessary, check your local plumbing codes to verify that final installation will be in compliance with their requirements.
3. On APCP models, secure the two power cords together using the four cable ties (Item 21), provided. Spiral these around the two cords at intervals of approximately five feet. Connect a garden hose to the hose adaptor, or use a 1 inch nipple and flexible PVC tubing secured to the pump discharge. Note: If flexible 1 inch PVC tubing is used, the free end must be secured so that it cannot blow back onto the pool cover in high wind.
4. Remove pump screen (Item 22) and base plate (Item 8) from the carton. The screen and the base plate are shipped unassembled. Prior to operating the pump, the screen and the base plate must be installed as shown in the replacement parts diagram. Attach the screen and the base plate using the 1/4-20 nylon screws (Item 9) and torque screws 8-10 in-lbs. NOTE: If the plate is not installed, pump may tip, which can result in switch malfunction and possible damage to the pump if switch causes pump to run without water being present. See SAFETY INSTRUCTIONS section. The plate is an integral part of the safety design of the pump, and failure to attach properly voids this important safety feature.
5. Gently lower pump with stabilizing plate onto the pool cover by holding onto the garden hose. Be certain that you do not pull power cord plug onto pool cover. It is recommended that two people position the pump. One person should hold onto electrical cord plugs while second person positions pump at desired location on pool cover. The pump is equipped with an 18 AWG power supply cord that is 25 feet long, and has a 3-prong grounding type plug. Once in position, and proper electrical connections have been made, the pump is ready for testing. See ELECTRICAL.

NOTE: Become familiar with the Safety Instructions. During the rainy season, you should check daily to see that your pump is functioning properly. Also, if you experience high winds, or excessive movement of the pool cover, be certain that the power supply cord has not been pulled onto the cover, and that the pump is still upright, with the discharge hose properly positioned. If you plan to be away from your pool for extended periods of time, it is recommended that a friend or neighbor periodically check your pool cover pump, and verify that everything is still functioning properly. Be sure to review the SAFETY INSTRUCTIONS and ELECTRICAL SHOCK HAZARDS with them!

OPERATION

AUTOMATIC OPERATION (APCP Models Only): The water level switch, rated 10 Amps, is activated by pressure against a diaphragm. This is caused by water rising around the switch housing with the pump resting upright on the stabilizing plate. This switch relies upon air to flow through a "breather tube" (See Figure 1). The switch should cause pump plugged into piggy back plug, (See Figure 1), to come on when the water level is approximately 2-3 inches deep. Pump should remain running until the water level is approximately .50-1.50 inches deep. Note: Temperatures near freezing may cause the "ON" level to go as high as 4 inches, and the "OFF" to be as high as 2 inches.

MANUAL OPERATION or OTHER USES: Pump can be operated manually by plugging its power cord directly into outlet. See SAFETY INSTRUCTIONS, paragraph #3. If pump is used for something other than pool cover water removal, the stabilizing plate can be removed by removing the four screws which attach it to the pump base. Remove the screen and then replace the screws to secure the screen to the pump base. Make sure you keep stabilizing plate. This is an important item which helps prevent pump from tipping and causing malfunctions to switch, and must be in place when pump is used on pool cover. See SAFETY INSTRUCTIONS and ELECTRICAL SHOCK HAZARD before converting pump for other applications.



NOTICE
▲ DANGER

THIS PUMP IS INTENDED TO REMOVE WATER FROM YOUR POOL COVER TO HELP PREVENT DAMAGE, BUT IS NOT INTENDED TO BE A LIFE-SAVING DEVICE TO PREVENT DROWNING IN COVER WATER. ACCUMULATED WATER DOES PRESENT A POTENTIAL DROWNING HAZARD AND POOL OWNER MUST TAKE ACTIONS TO PREVENT THIS SHOULD THE PUMP FAIL TO OPERATE.

SAFETY INSTRUCTIONS

Read these instruction carefully. Failure to follow could cause serious bodily injury and/or property damage. Your pump is an electrical product and caution should be used when handling the pool cover pump or its electrical cord. Small children or pets may require restraining devices to prevent them from entering wet areas surrounding the pump or its power supply connections.



WARNING ELECTRICAL SHOCK HAZARD

1. This product is provided with a three prong grounding plug, to reduce the risk of electrical shock. When pump is in operation, make sure it is properly connected to grounded outlet. For additional safety, a GFCI device is recommended either at the outlet supplying power to the pump or at Circuit Breaker Panel Box. An in line GFCI is included on GFCI Models.
2. Never pump chemicals or corrosive liquids with this pump. This could damage the integrity of the enclosure and cause an electrical short.
3. Do not run this pump dry. If switch does fail or pump is used manually, always be certain that water is available. Running this pump without water may damage the integrity of the enclosure and cause electrical short.
4. If service is required, proceed carefully. The pump and surrounding areas may be covered with water. Never plug or unplug the device while standing in wet or damp surfaces. If necessary, remove power at the Breaker Panel or have a certified electrician remove power before attempting to service. Serious or fatal shocks could result if proper procedures are not followed.
 - A. Disconnect the power at the main electrical service box, by switching the appropriate circuit breaker or removing fuse. In applications where screw type fuses are used, remove only with one hand while other hand or torso are free from contact with anything. Do not stand in water and do not touch any other conductive surface.
 - B. Remove pump cord plug only after the power to the supply outlet has been removed. See Service Instructions before proceeding.
5. Remove pump when freezing conditions will cause water to freeze. Freezing water may result in rupture to pump and/or switch enclosure and could result in possible electrical short.



WARNING FIRE HAZARD

6. Never pump gasoline or other low flash point fluids with this pump. Explosion or fire could result.

ELECTRICAL

1. Your pump is supplied with a 3-prong electrical plug. The diaphragm switch on APCP models is supplied with a 3-prong piggyback plug/receptacle on the cord. The third prong is to ground the pump to prevent possible electrical shock hazard. Do not remove the third prong from the plugs. For automatic operation, plug pump plug into piggyback receptacle, then plug piggyback plug into properly grounded outlet. For manual operation, plug pump directly into properly grounded outlet. These connections are illustrated in Fig. 1.
2. A separate branch electrical circuit is recommended. The electrical power required is 5 amps at 115 VAC.
3. Be sure that electrical connection cannot be reached by rising water. Under no circumstances should the connection be located where it may become flooded or submerged by water.
4. Switch cord contains a small white breather tube which extends out of switch plug (see Fig. 1). Be sure switch cord is not pinched and non-restrictive air flow can occur in breather tube. Do not allow water to enter into breather tube. Non-restricted air flow is required for proper switch operation.

- On GFCI models, test GFCI device per the instructions on the back of the device. Test the pump after all electrical connections have been made. Run water into area where pump is to be placed. Do not attempt to run the pump without water; this could cause damage to the pump. Fill the area to a normal "On" level and allow the pump to remove water to a normal "Off" level.

⚠ WARNING

Always disconnect the electrical power before touching the pump, discharge or electrical plug when water is present in the area. Failure to do so can result in serious bodily injury and/or property damage. Always connect pump to grounded receptacle. See Safety Instructions.

SERVICE INSTRUCTIONS

⚠ WARNING ELECTRICAL SHOCK HAZARD

- CAUTION:** Before servicing the pump, disconnect the pump from electrical service, unplug cord, remove fuse or turn off disconnect box.
- The motor housing of the pump is completely sealed and requires no service. Disassembly of the motor housing or alteration of the power cord voids all warranty.
- The motor is a continuous duty type sealed in oil with an automatic thermal overload protector device.

- The pump can run against a restricted discharge such as a fountain without damage to the pump.
- Keep pump clean and in a well maintained condition at all times. Pump should be thoroughly cleaned for summer storage. If the pump becomes clogged, remove the four screws which secure the plate to the pump and clean out the debris.
- If necessary remove the six (6) screws holding the volute base to the motor housing and clean the volute. These screws are located under the plastic stabilizer plate on the base of the pump. (See item 7 on the replacement parts page). If the impeller is removed make sure that a spacing of .050" with shaft pushed toward housing is maintained when reassembling. (See Fig. 2).
- When reassembling be certain seal surfaces are clean and install the seal ring between the volute base and the motor housing. Note that the stabilizer plate is a safety feature for pool cover applications to prevent pump from falling over and causing switch malfunctions. Make certain that the plate is in good condition and is properly secured to the pump base. Tighten plate mounting screws to 8 in. - lb. torque.
- This pump does not require lubrication inside the motor enclosure. The motor housing is filled at the factory with a dielectric oil for motor heat transfer and lifetime lubrication of the bearings. Use of any other oil could cause damage and will void the warranty. If oil escapes from the enclosure, disconnect power to the pump and remove pump from application.

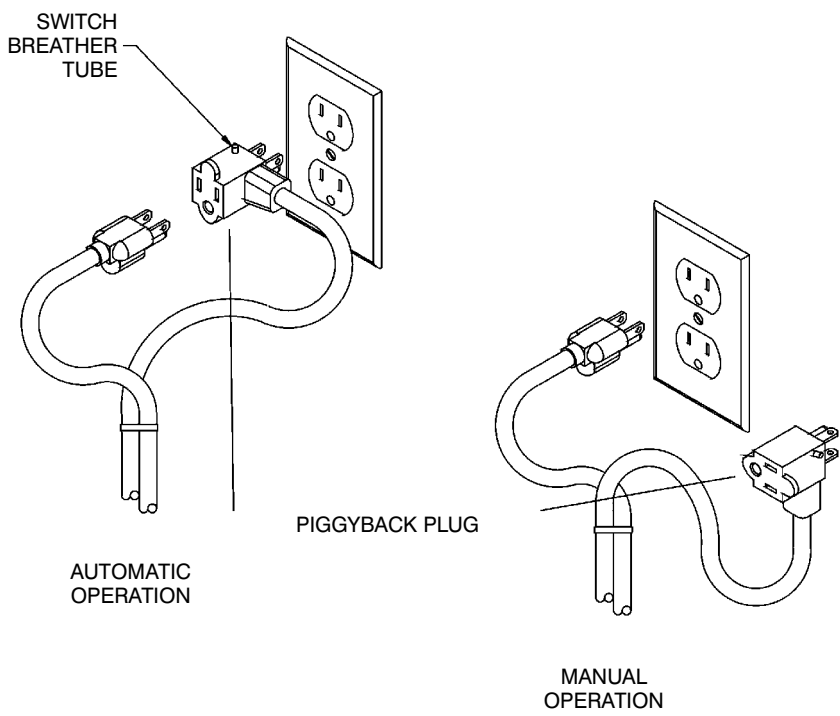

FIG 1

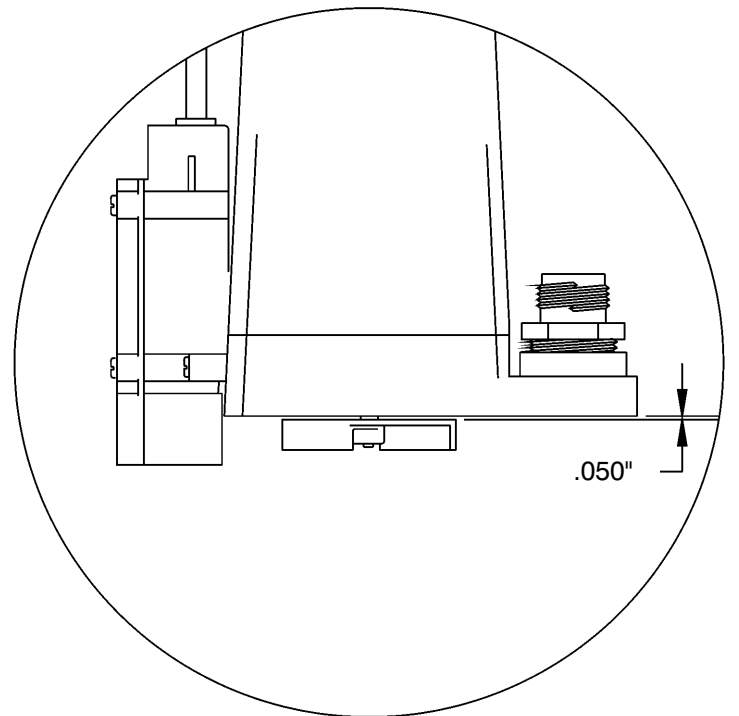
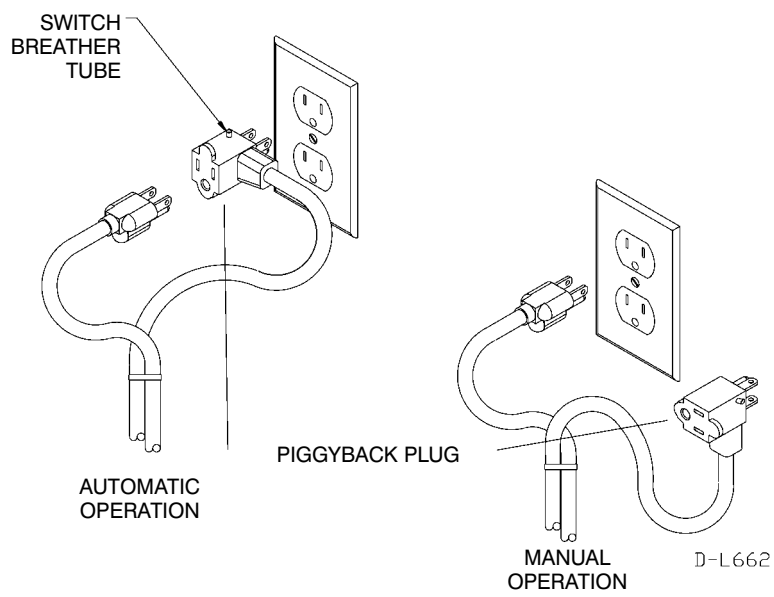

FIG 2

TROUBLESHOOTING INFORMATION

PROBLEM	PROBABLE CAUSES	CORRECTIVE ACTION
Pump will not shut off.	Plugged vent tube in power cord.	Clear vent tube of any obstruction.
	Sediment lodged between retainer ring and rubber diaphragm causing contacts to remain closed.	Clean area around rubber diaphragm.
	Pump plugged directly into outlet.	See Figure 1
	Defective switch.	Operate pump manually (see Figure 1). Replace switch if necessary. Disconnect switch, check w/ohmmeter. Open-infinite resistance, closed-zero. With no water present switch should be open. Replace switch.
	Weak rubber diaphragm.	Replace diaphragm.
	Pump is air locked.	Shut power off for approximately 1 minute, then restart. Repeat several times to clear air from pump. If system includes a check valve, a 3/16" hole should be drilled in discharge pipe approximately 2" above discharge connections.
Pump runs, but does not discharge liquid.	Liquid inflow matches or exceeds pump capacity.	Larger pump required or multiple pumps. See capacity sizing information.
	Frozen water in discharge hose.	Thaw hose or replace hose.
	Check valve installed backwards. Note: Check valve is accessory item.	Check flow indicating arrow on check valve body to insure it is installed properly.
	Check valve stuck or plugged.	Remove check valve and inspect for proper operation.
	Lift too high for pump.	Check rating table.
	Inlet to impeller plugged.	Pull pump and clean.
Pump does not deliver rated capacity	Pump is air locked.	(See corrective action above).
	Frozen water in discharge hose.	Thaw hose or change out.
	Lift too high for pump.	Check rated pump performance.
Pump cycles continually.	Low voltage, speed too low.	Check for proper supply voltage to make certain it corresponds to nameplate voltage.
	Impeller or discharge pipe is clogged.	Pull pump and clean. Check pipe for scale or corrosion.
	Impeller wear due to abrasives.	Replace worn impeller.
Pump will not operate.	No check valve in long discharge pipe allowing liquid to drain back onto cover.	Install a check valve in discharge line.
	Check valve leaking.	Inspect check valve for correct operation.
	Blown fuse.	Replace fuse.
	Switch failed.	Disconnect switch plug and plug pump only into electrical socket. If pump operates then replace switch. If pump does not operate, have pump serviced.
	Volute clogged.	Clean screen and basket.
	Breather tube clogged.	Clear vent tube of any obstruction.
	Diaphragm passage clogged.	Clear passage of any obstruction.
	Motor failure.	Have pump serviced.
Thermal protector activated.	Allow pump to cool.	
GFCI device activated.	Inspect all electrical connections and reset GFCI.	



PIGGYBACK PLUG INSTALLATION
FIG 1

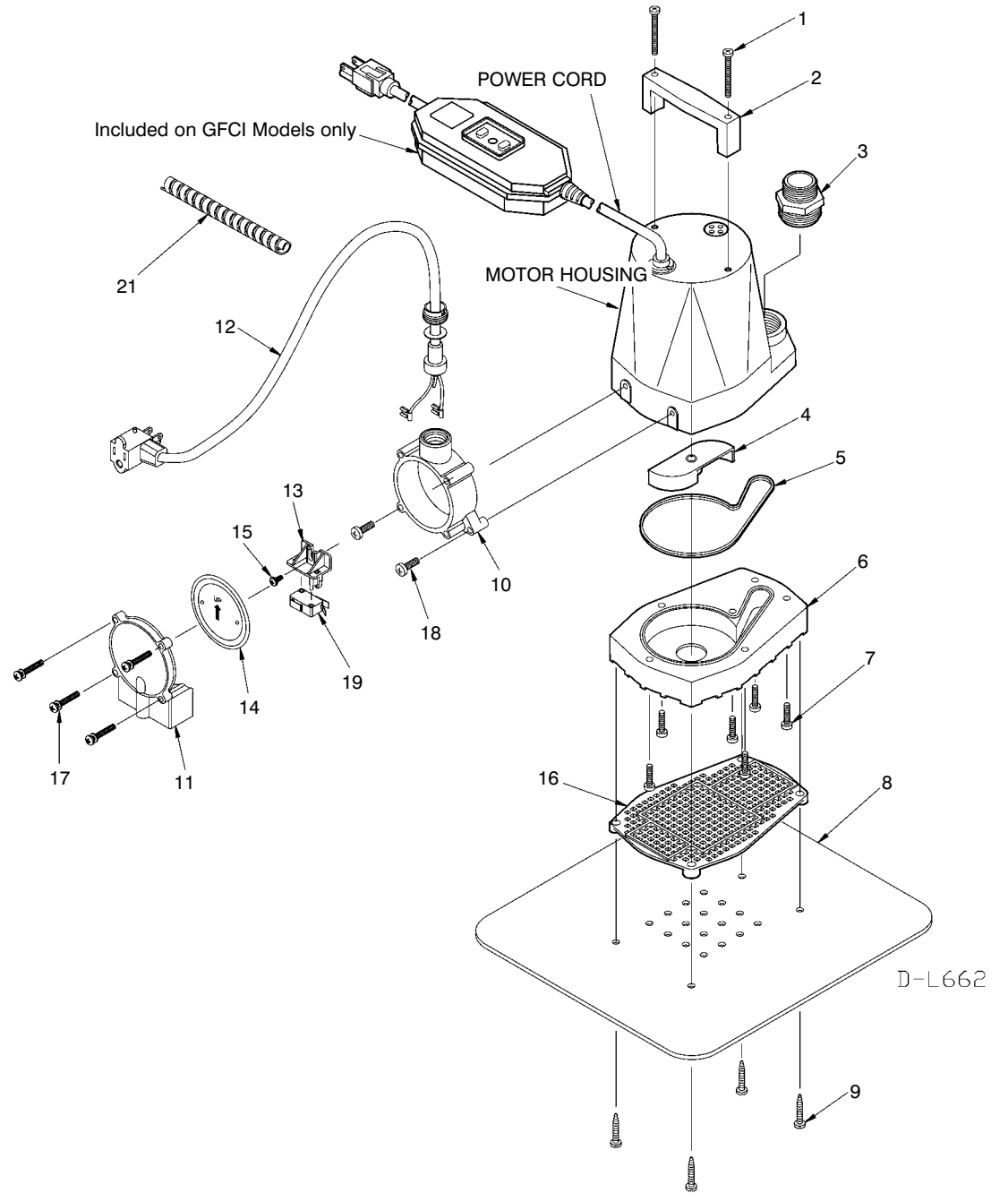

REPLACEMENT PARTS LIST

ITEM	P/N	DESCRIPTION	5-APCP 505600	5-APCP-GFCI 505611
1	902441	SCREW, #8-18 X 1 5/8" (2)	2	2
2	105377	HANDLE	1	1
3	941044	ADAPTOR	1	1
4	105310	IMPELLER	1	1
5	928024	SEAL RING	1	1
6	105908	VOLUTE BASE	1	1
7	902434	SCREW, #8-18 X 3/4"	6	6
8	105600	STABILIZER PLATE	1	1
9	909036	SCREW, 1/4-20 X 3/4"	4	4
10	105902	SWITCH HOUSING	1	1
11	105903	SWITCH HOUSING COVER	1	1
12	951056	WIRING HARNESS, 25 FT.	1	1
13	108202	BRACKET	1	1
14	108125	DIAPHRAGM ASSEMBLY	1	1
15	902404	SCREW, #8-18 X 3/8"	1	1
16	105909	SCREEN	1	1
17	902512	SCREW, #10-10 X 3/4"	4	4
18	902513	SCREW, #10-16 X 1-1/8"	2	2
19	950324	SWITCH	1	1
20	950902	TY-RAP (NOT SHOWN)	1	1
21	950985	CABLE TIE (HELI-TUBE)	5	5

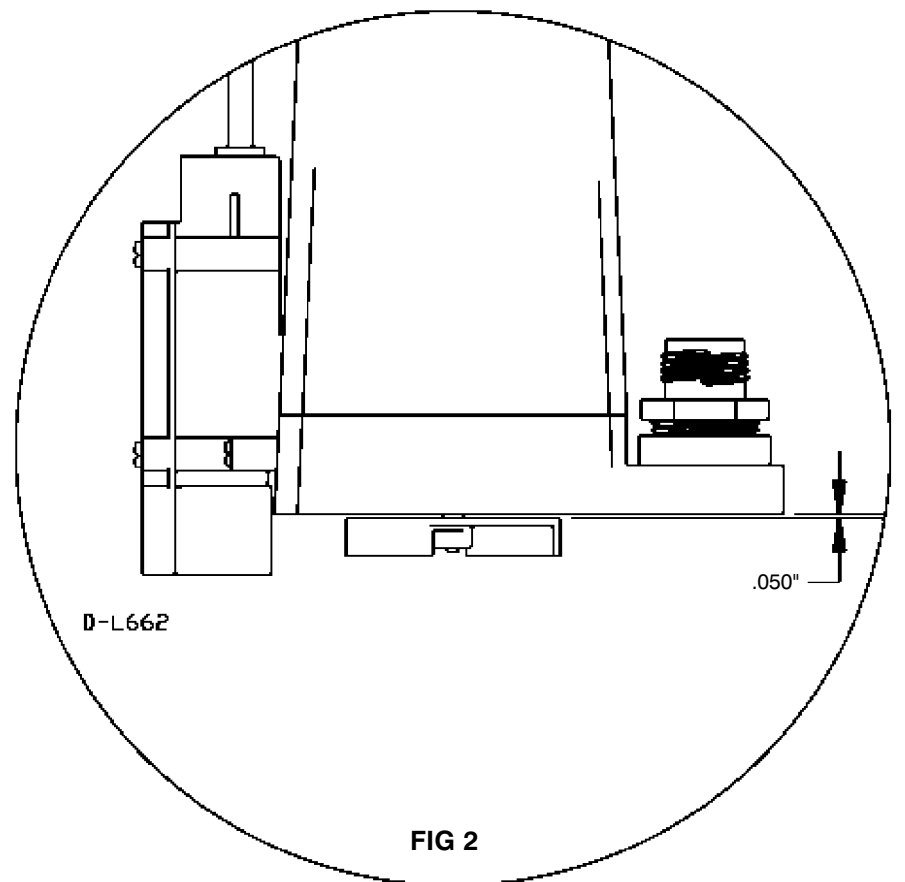

FIG 2

Complete Switch Assembly is Catalog #599019.

Note: Pump enclosure is die-cast aluminum and is coated with epoxy paint. Motor shaft is 440 stainless steel and shaft seal is Fluro-elastomer. The electrical cords are PVC.

LITTLE GIANT WARRANTY STATEMENT

Your Little Giant product is guaranteed to be in perfect condition when it leaves our Factory. It is warranted against defective materials and workmanship for a period of 12 months (90 day warranty on Models: 1-AA-OM, GKPK-SC, PP-1, PPS-1, PP-12, PPS-12 , PP-230 and Cooler King) from date of purchase by the user. No warranty on brush wear in Model 35-OM and impeller or cam in Models PP-1, PP-12, and PP-230. Any product that should fail for either of the above two reasons and is still within the warranty period will be repaired or replaced if returned prepaid to our Factory. All defective products returned under warranty will be fully inspected to determine "CAUSE OF FAILURE" before any warranty is approved. Little Giant will honor the warranty within the warranty time period specified on satisfactory written proof of purchase.

DISCLAIMER: Any oral statements about the product made by the seller, the manufacturer, the representatives or any other parties, do not constitute warranties, shall not be relied upon by the user, and are not part of the contract for sale. Seller's and manufacturer's only obligation, and buyer's only remedy, shall be the replacement and/or repair by the manufacturer of the product as described above. Neither seller nor the manufacturer shall be liable for any injury, loss or damage, direct, incidental or consequential (including, but not limited to, incidental or consequential damages for lost profits, lost sales, injury to person or property, or any other incidental or consequential loss), arising out of the use or the inability to use the product, and the user agrees that no other remedy shall be available to it. Before using, the user shall determine the suitability of the product for his intended use, and user assumes all risk of liability whatsoever in connection therewith. **The warranty and remedy described in this limited warranty is an EXCLUSIVE warranty and remedy and is IN LIEU OF any other warranty or remedy, expressed or implied, which other warranties and remedies are hereby expressly EXCLUDED, including but not limited to any implied warranty of MERCHANTABILITY OR FITNESS FOR A PARTICULAR PURPOSE.** Some states do not allow the exclusive or limitation of incidental or consequential damages, so the above limitation or exclusion may not apply to you. This warranty gives you specific legal rights, and you may also have other rights which vary from state to state.

Warranty will be VOID if any of the following conditions are found:

1. Sealed motor housing opened.
2. Product connected to voltage other than indicated on name plate.
3. Cord cut off to a length less than three feet.
4. Pump allowed to operate dry (fluid supply cut off).
5. Pump used to circulate anything other than fresh water, light oils, or other mild liquids at approximately room temperature.
6. Product abuse by customer.

The National Electric Code requires a Ground Fault Circuit Interrupter (GFCI) be installed in the branch circuit supplying fountain equipment rated above 15 volts. Little Giant Pump Company offers a variety of GFCI's and recommends each pump be used with a GFCI.

KEEP THIS FOLDER

File this for safekeeping. It may be valuable to you for service under the terms of the warranty.

Date of purchase _____

Name of Dealer _____

Serial # _____



Little Giant Pump Company
3810 N. Tulsa Street
Oklahoma City, OK 73112

©Copyright 2002 Little Giant Pump Co.
Form 994169 — 09/2002
Little Giant Print Services