

# Little GIANT®

## 9S SERIES



### Features

- Handles liquids and solid waste materials up to 2" diameter
- Cast iron pump housing and cover with protective epoxy coating for corrosion resistance
- Oil-filled motor housing for lifetime lubrication and rapid heat dissipation
- Stainless steel fasteners
- Mechanical seals (stainless steel spring, nitrile parts, carbon and ceramic faces)
- Thermal overload protection
- Manual and Automatic models available
- Automatic operation has 9" to 14" "On" level and 2" to 6" "Off" level range with piggyback mechanical float switch
- All 115 volt models are UL/CSA listed

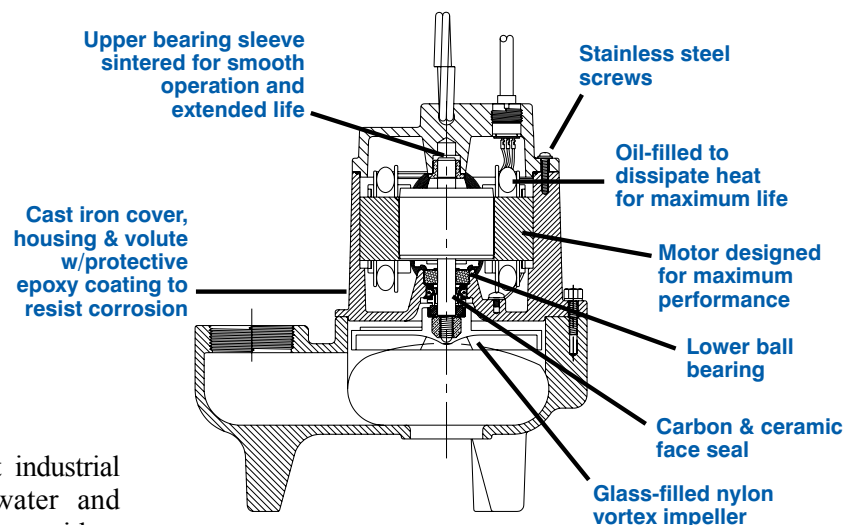

For residential, medium commercial and light industrial applications, the Model 9S Series Wastewater and Sewage Ejector pumps feature a 2" discharge, with a maximum lift of 18'. Cast iron housing, cover and volute have a protective epoxy coating.

# 9S SERIES

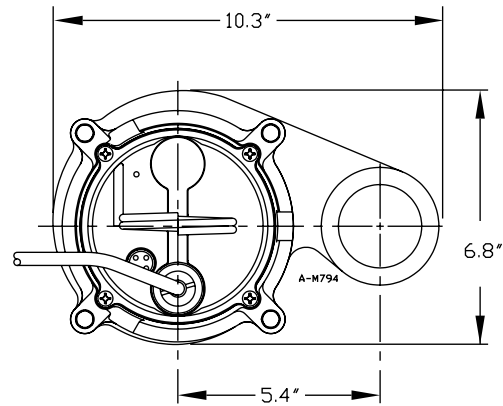
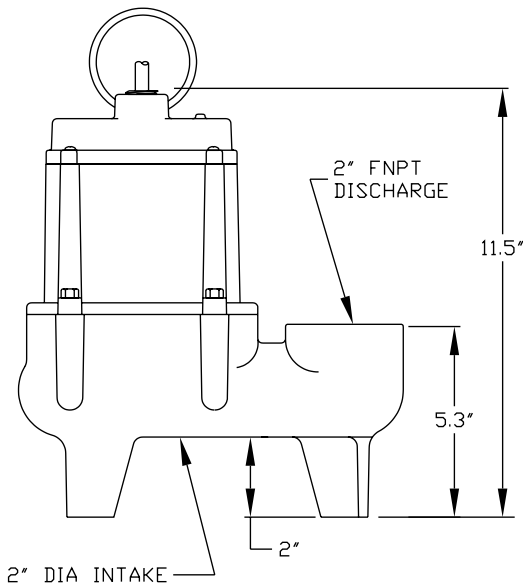

## Specifications

Model No.	Item No.	Listing	HP	Volts	Solids Size (dia. in.)	Running Amps/Watts	Performance (GPM@Head)				Shutoff		Cord Length (ft.)	Weight (lbs.)	Dimensions H x L x W (in.)
							5'	10'	15'	20'	Ft.	P.S.I.			
9S-CIM	509400	UL/CSA	4/10	115	2"	13/1020	80	50	16	—	18	7.8	15	36	11.6 x 10.3 x 6.8
9S-CIA-RFS	509500	UL/CSA	4/10	115	2"	13/1020	80	50	16	—	18	7.8	15	36	11.6 x 10.3 x 6.8
9S-CIM	509450	—	4/10	230	2"	6.5/1020	80	50	16	—	18	7.8	15†	36	11.6 x 10.3 x 6.8
9S-CIA-RFS	509520	UL/CSA	4/10	115	2"	13/1020	80	50	16	—	18	7.8	20	37	11.6 x 10.3 x 6.8
9S-CIA-RFS*	509510	UL/CSA	4/10	115	2"	13/1020	80	50	16	—	18	7.8	15	37	11.6 x 10.3 x 6.8
9S-CIM*	14940723	UL/CSA	4/10	115	2"	13/1020	80	50	16	—	18	7.8	15	37	11.6 x 10.3 x 6.8
9S-CIM*	14940724	—	4/10	230	2"	6.5/1020	80	50	16	—	18	7.8	15†	37	11.6 x 10.3 x 6.8

\*3" discharge RFS - Piggyback Mechanical Float Switch

†tw/out plug

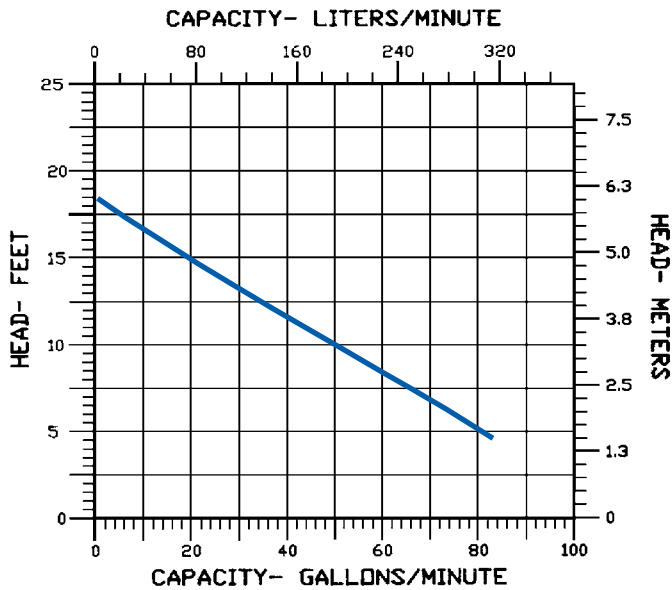

## Construction

Cover	Epoxy-coated cast iron
Motor Housing	Epoxy-coated cast iron
Impeller Material	Nylon
Impeller Type	Vortex
Volute	Epoxy-coated cast iron
Power Cord	SJTW
Mechanical Shaft Seal	Nitrile with carbon and ceramic faces
Fasteners	Stainless steel
Shaft	Steel
Bearings	Upper sintered sleeve and lower ball bearing

## 9S-CIM 9S-CIA-RFS Submersible Sewage Ejector Pump

are capable of operating with the motor housing partially exposed for extended periods of time, providing sufficient motor cooling and bearing lubrication, however, for the best cooling and longest motor life, the liquid level being pumped should normally be above the top of the cast iron motor housing.

### SAFETY GUIDELINES



**WARNING: RISK OF ELECTRIC SHOCK.** This pump is supplied with a grounding conductor and/or grounding-type attachment plug. To reduce the risk of electric shock, be certain that it is connected to a properly grounded grounding-type receptacle.

Your 115V sewage ejector pump is equipped with a 3-prong electrical plug. The third prong is to ground the pump to prevent possible electrical shock hazard. Do not remove the third prong from the plug. A separate branch circuit is recommended. Do not use an extension cord.

When a pump is in a basin, etc., do not touch motor, pipes or water until unit is unplugged or shut off. If your installation has water or moisture present, do not touch wet area until all power has been turned off. If shut-off box is not accessible, call the electric company to shut off service to the house, or call your local fire department for instructions. Failure to follow this warning can result in fatal electrical shock.

The flexible PVC jacketed cord assembly mounted to the pump must not be modified in any way, with the exception of shortening the cord to fit into a control panel. Any splice between the pump and the control panel must be made within a junction box and mounted outside of the basin, and comply with the National Electrical Code. Do not use the power cord for lifting the pump.

The pump motor is equipped with an automatic resetting thermal protector and may restart unexpectedly. Protector tripping is an indication of motor overloading as a result of operating the pump at low heads (low discharge restriction), excessively high or low voltage, inadequate wiring, incorrect motor connections, or a defective motor or pump.

1. Read all instructions and safety guidelines thoroughly. Failure to follow the guidelines and the instructions could result in serious bodily injury and/or property damage.
2. DO NOT USE TO PUMP FLAMMABLE OR EXPLOSIVE FLUIDS SUCH AS GASOLINE, FUEL OIL, KEROSENE, ETC. DO NOT USE IN EXPLOSIVE ATMOSPHERES OR HAZARDOUS LOCATIONS AS CLASSIFIED BY NEC, ANSI/NFPA70. FAILURE TO FOLLOW THIS WARNING CAN RESULT IN PERSONAL INJURY AND/OR PROPERTY DAMAGE.
3. During normal operation the pump is immersed in water. Also, during rain storms, water may be present in the surrounding area of the pump. Caution must be used to prevent bodily injury when working near the pump:
  - a. The plug must be removed from the receptacle prior to touching, servicing or repairing the pump.
  - b. To minimize possible fatal electrical shock hazard, extreme care should be used when changing fuses. Do not stand in water while changing fuses or insert your finger into the fuse socket.
4. Do not run the pump in a dry basin. If the pump is run in a dry basin, the surface temperature of the pump will rise to a high level. This high level could cause skin burns if the pump is touched and will cause serious damage to your pump.
5. Do not oil the motor. The pump housing is sealed. A high grade dielectric oil devoid of water has been put into the motor housing at the factory. Use of other oil could cause serious electric shock and/or permanent damage to the pump.
6. This pump's motor housing is filled with a dielectric lubricant at the factory for optimum motor heat transfer and lifetime lubrication of the bearings. Use of any other lubricant could cause damage and void the warranty. This lubricant is non-toxic; however, if it escapes the motor housing, it should be removed from the surface quickly by placing newspapers or other absorbent material on the water surface to soak it up, so aquatic life is undisturbed.
7. In any installation where property damage and/or personal injury might result from an inoperative or leaking pump due to power outages, discharge line blockage, or any other reason, a backup system(s) and/or alarm should be used.

## INTRODUCTION

This instruction sheet provides you with the information required to safely own and operate your product. Retain these instructions for future reference.

The product you have purchased is of the highest quality workmanship and material, and has been engineered to give you long and reliable service. This product has been carefully tested, inspected, and packaged to ensure safe delivery and operation. Please examine your item(s) carefully to ensure that no damage occurred during shipment. If damage has occurred, please contact the place of purchase. They will assist you in replacement or repair, if required.

**READ THESE INSTRUCTIONS CAREFULLY BEFORE ATTEMPTING TO INSTALL, OPERATE, OR SERVICE YOUR PRODUCT. KNOW THE PRODUCT'S APPLICATION, LIMITATIONS, AND POTENTIAL HAZARDS. PROTECT YOURSELF AND OTHERS BY OBSERVING ALL SAFETY INFORMATION. FAILURE TO COMPLY WITH THESE INSTRUCTIONS COULD RESULT IN PERSONAL INJURY AND/OR PROPERTY DAMAGE!**

## DESCRIPTION

Little Giant Submersible Sewage Ejector Pumps are recommended for use in basins or lift stations and suitable for pumping sewage, effluent, wastewater and other non-explosive, non-corrosive liquids with up to 2" spherical solids.

Automatic operation can be achieved with the use of the RFS Remote Float Switch. Other accessories such as basins, check valves and covers are also available.

## SPECIFICATIONS

- Discharge:** 2" or 3" NPT vertical
- Intake:** 2" diameter opening
- Housing:** Cast iron
- Volute:** Cast iron
- Impeller:** Vortex design with pressure relief vanes
- Motor:** Single-phase induction 1750 RPM with automatic reset thermal overload protection
- Hardware:** 300 series stainless steel
- Thrust Bearing:** Ball
- Radial Bearing:** Sleeve – permanent lubrication
- Shaft Seal:** Mechanical, spring loaded, stationary carbon with rotating ceramic seat
- Power Cord:** 16 AWG 3-conductor copper stranded
- Cooling:** The motor housing contains a cooling oil to provide cooling for the motor and to lubricate bearings and seals. These pumps

Figure 1

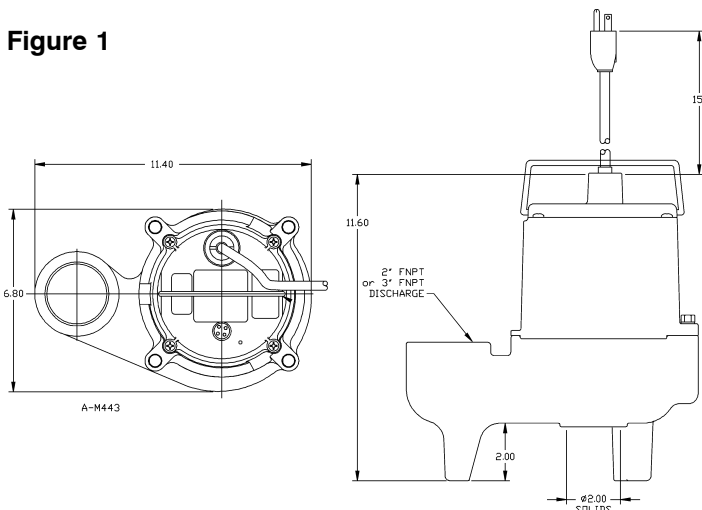

## INSTALLATION

Pump must be installed in a suitable gas-tight basin which is at least 18" in diameter and 24" deep, and vented in accordance with local plumbing codes.

Pump features a 2" or 3" female NPT discharge.

Pump can be installed with ABS, PVC, polyethylene or galvanized steel pipe.

MODEL NO.	LISTING	VOLTS	HP	AMPS/ WATTS	GPM @ HEAD			SHUT OFF (ft.)	P.S.I.	PWR CRD (ft.)	WT. (lbs.)
					5'	10'	15'				
9S-CIM	UL	115	4/10	13.0/1015	80	50	16	18.0	7.8	15	33
9S-CIM	—	230	4/10	6.5/1120	80	50	16	18.0	7.8	15	33
9S-CIA-RFS	UL	115	4/10	13.0/1015	80	50	16	18.0	7.8	15	34

Proper adapters are required to connect plastic pipe to pump.

Pump must be placed on a hard level surface. Never place pump directly on clay, earth or gravel surfaces.

A check valve must be used in the discharge line to prevent back flow of liquid into the basin. The check valve should be a free flow valve that will easily pass solids.

**CAUTION:** For best performance of check valves, when handling solids install in a horizontal position or at no more than at a 45° angle. Do not install check valve in a vertical position as solids may settle in valve and prevent opening on start-up. When a check valve is used drill a 3/16" hole in the discharge pipe approximately 1" to 2" above the pump discharge connection and below check valve to prevent air locking of the pump.

### WIRING

Check local electrical and building codes before installation. The installation must be in accordance with their regulations as well as the most recent National Electrical Code (NEC).

To conform to the National Electrical Code, all pumps must be wired with 14 AWG or larger wire. For runs to 250', 14 AWG wire is sufficient. For longer runs consult a qualified electrician or the factory.

Pump should be connected or wired to its own circuit with no other outlets or equipment in the circuit line. Fuses and circuit breaker should be of ample capacity in the electrical circuit. See Table 2.

### REMOTE FLOAT SWITCH LEVEL CONTROL

The RFS series pumps are equipped with a remote float switch level control. This level control is sealed in a polypropylene float cylinder. For automatic operation, the pump must be plugged or wired into a remote float switch. Pump will run continuously if plugged directly into an electrical outlet.

When the level rises in the basin, the cylinder floats up with the level. When the cylinder position is at an angle of about 45°, the switch activates and starts the pump motor.

As the level draws down, the cylinder floats down and when it is again at an angle of about 45°, the switch deactivates, and the pump motor stops.

**NOTE:** BE CERTAIN PUMP IS SECURE IN BASIN AND CYLINDER FLOATS UNOBSTRUCTED WITHOUT TOUCHING THE BASIN WALLS OR PLUMBING.

### REMOTE FLOAT SWITCH INSTALLATION

1. The float switch consists of three parts: 1) switch, 2) cord clamp, and 3) clamp screw. **NOTE:** If screw is lost, use a #10-16 x 1/2" long tapping screw.
2. Attach cord clamp to pump cover as shown in the switch instruction manual packaged with the switch. The clamp and pump handle must be positioned as shown to allow free operation of float. Be sure to locate pump and switch power cords away from switch float.

Table 1

H.P.	VOLTAGE	FUSE OR CIRCUIT BREAKER AMPS
4/10	115	20
4/10	230	15

Figure 2

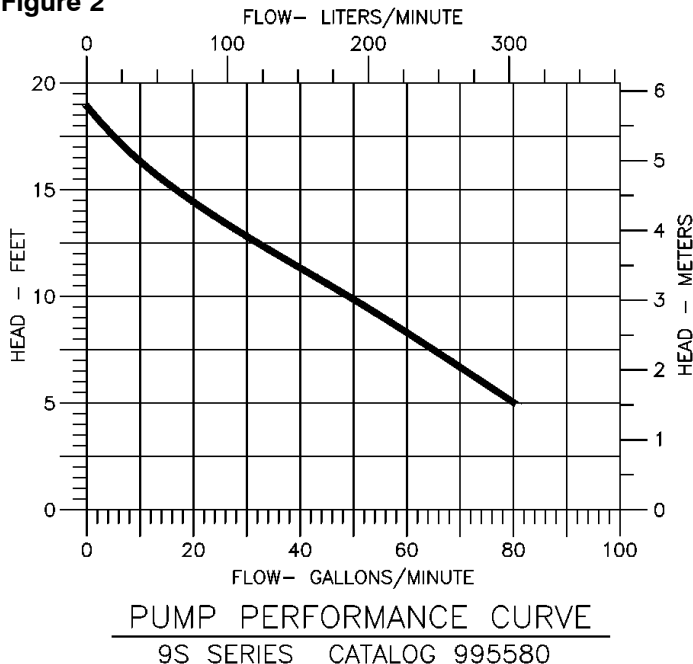

3. A 3.5" tether length is recommended. When a tether length of 3.5" is used, a minimum basin diameter of 18" is recommended. The tether length is measured as shown in Figure 3.

4. After desired tether length is established, hand-tighten clamp screw.
5. **TESTING:** Without water in basin plug pump power cord into switch in-line-plug. Plug switch into outlet. Lift float and watch for pump to operate. Do not run pump for more than 5 seconds.

### TESTING PUMP OPERATION

#### RFS SERIES SEWAGE EJECTOR PUMPS

1. These pumps are equipped with a remote float switch.
2. These pumps are installed in a basin with a sealed cover, so switch operation cannot be observed. The sump cover usually will have a spare hole that is plugged with a rubber plug. This plug can be removed and switch operation can be observed.
3. Plug power cord and remote float switch power cord into a grounded receptacle with voltage consistent with pump voltage as indicated on pump nameplate.
4. Run water into basin until pump starts.
5. Be sure gate valve in discharge line is open.
6. Allow pump to operate through several on-off cycles.

#### MANUAL SEWAGE EJECTOR PUMPS

The pump cord for these pumps can be plugged directly into a properly grounded receptacle with voltage consistent with pump nameplate for continuous pump operation.

**CAUTION:** This type of operation should be used only for emergency use or when a large volume of water is to be pumped. Pump must not be allowed to run dry. If pump is run dry, it may damage pump and void the warranty.

### MAINTENANCE AND SERVICE

If pump does not operate properly, consult the Troubleshooting Chart. If trouble cannot be located with these steps shown, consult your pump dealer or take pump to a Little Giant authorized service center.

**CAUTION:** When working on pump or switch, always unplug pump power cord in addition to removing fuse or shutting off circuit breaker before working on pump.

### CLEANING IMPELLER AND VOLUTE

1. Remove screws that hold volute to motor housing.
2. Remove volute and clean impeller and volute passage. Do not use strong solvents on impeller.
3. Be sure impeller turns freely after cleaning.
4. **WARNING:** DO NOT REMOVE IMPELLER. REMOVAL OF IMPELLER REQUIRES SPECIAL TOOLS AND IS TO BE DONE ONLY BY AN AUTHORIZED SERVICE CENTER.

DO NOT REMOVE MOTOR HOUSING COVER. WARRANTY IS VOID IF MOTOR HOUSING COVER, IMPELLER OR SEALS HAVE BEEN REMOVED. ANY REPAIR ON MOTOR MUST BE DONE BY AN AUTHORIZED LITTLE GIANT SERVICE CENTER.

Figure 3

### 9S AUTOMATIC TYPICAL INSTALLATION

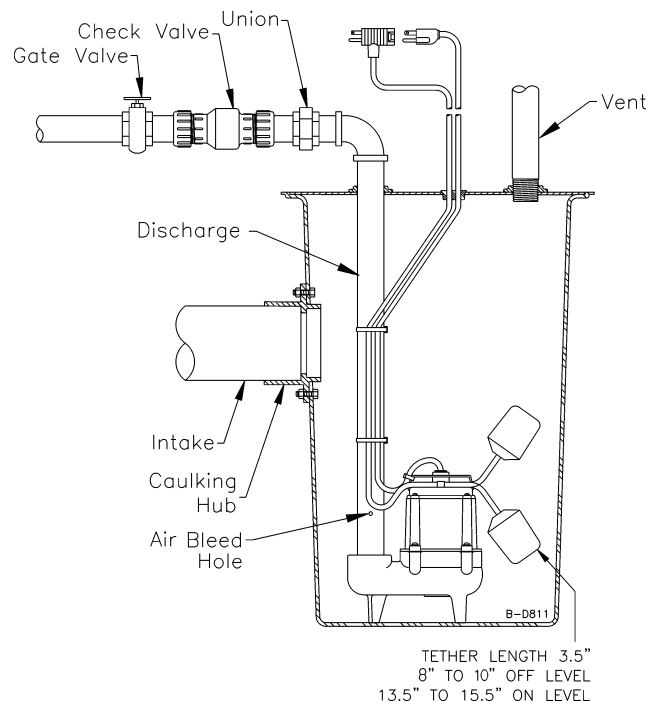

**Figure 4**

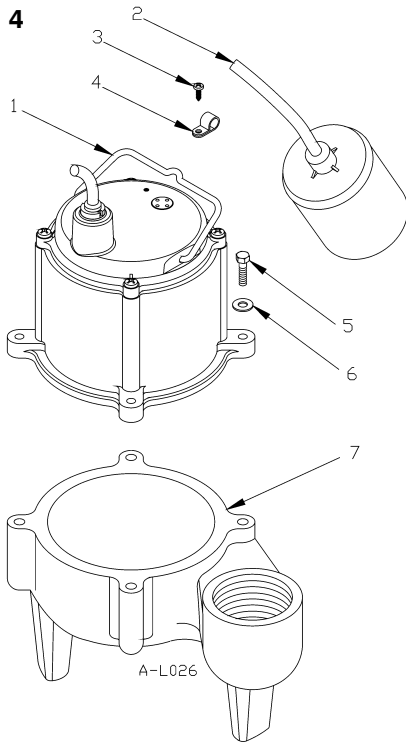

ITEM NO.	PART NO.	PARTS DESCRIPTION	9S-CIM 509400	9S-CIA-RFS 509450	9S-CIA-RFS 509500	9S-CIM 509520	9S-CIM, 3" DISCH. 14940723	9S-CIM, 3" DISCH. 14940724
1	108101	Handle, Pump	1	1	1	1	1	1
2	950315	Remote Float Switch	--	--	1	--	--	--
2	950307	Remote Float Switch	--	--	--	1	--	--
3	902516	Screw, Tapping #10-24 x 1/2"	--	--	1	1	--	--
4	927027	Clamp, Cord	--	--	1	1	--	--
5	915907	Bolt, Hex Head	4	4	4	4	4	4
6	921103	Washer, Lock	4	4	4	4	4	4
7	111415	Volute, 2" Discharge	1	1	1	1	--	--
7	111540	Volute, 3" Discharge	--	--	--	--	1	1
8	950905	Ty-Rap (not shown)	--	--	1	1	1	1

### TROUBLESHOOTING INFORMATION

PROBLEM	PROBABLE CAUSES	CORRECTIVE ACTIONS
Pump does not turn on. <b>NOTE:</b> Before troubleshooting automatic control, check to see that pump operates on manual control. To do this, unplug from in-line float switch plug. Plug pump power cord into wall outlet. If pump works, proceed to check switch, if not, fault is in pump or power supply.	Pump not plugged in.	Plug in pump.
	Circuit breaker shutoff or fuse removed.	Turn on circuit breaker or replace fuse.
	Accumulation of trash on mercury float switch.	Clean float.
	Remote float switch obstruction.	Check float path and provide clearance.
	Defective switch.	Disconnect switch, check with ohmmeter. Open-infinite resistance, closed-zero.
	Defective motor.	Have pump serviced.
Pump will not shut off.	Remote float switch obstruction.	Check float path and provide clearance.
	Pump is air locked.	Shut power off for approximately 1 minute, then restart. Repeat several times to clear air from pump. If system includes a check valve, a 3/16" hole should be drilled in discharge pipe approximately 2" above discharge connections.
	Liquid inflow matches pump capacity.	Larger pump required.
	Defective switch.	Disconnect switch, check w/ohmmeter, Open-infinite resistance, closed-zero.
	Loose connection in level control wiring.	Check control wiring.
Pump runs but does not discharge liquid.	Check valve installed backwards.	Check flow indicating arrow on check with ohmmeter. Open-infinite resistance, closed-zero.
	Check valve stuck or plugged.	Remove check valve and inspect for proper operation.
	Lift too high for pump.	Check rating table.
	Inlet to impeller plugged.	Pull pump and clean.
	Pump is air locked.	(See corrective action above.)
Pump does not deliver rated capacity.	Lift too high for pump.	Check rated pump performance.
	Low voltage, speed too slow.	Check for proper supply voltage to make certain it corresponds to nameplate voltage.
	Impeller or discharge pipe is clogged.	Pull pump and clean. Check pipe for scale or corrosion.
	Impeller wear due to abrasives.	Replace worn impeller.
Pump cycles continually.	No check valve in long discharge pipe allowing liquid to drain back into basin.	Install a check valve in discharge line.
	Check valve leaking.	Inspect check valve for correct operation.
	Basin too small for inflow.	Install larger basin.

**LIMITED WARRANTY  
SUMP, EFFLUENT & RESIDENTIAL SEWAGE**

Little Giant #8E, #9E, #10E, #14EH and #16EH Series Submersible Effluent Pumps are recommended for use in sumps, basins or lift stations and suitable for pumping basement drainage water, effluent, wastewater and other non-explosive, non-corrosive, non-abrasive liquids not above 140°F with up to 3/4" spherical solids handling ability. (NOT TO BE USED FOR SEWAGE WATER EXCEPT TO PUMP SEPTIC TANK EFFLUENT.)

Little Giant #9S, #10S, #14S, and #16S Series Submersible Sewage Ejector Pumps are recommended for use in sumps, basins or lift stations and suitable for pumping sewage, effluent, wastewater, and other non-explosive, non-corrosive, non-abrasive liquids not above 140°F with up to 2" spherical solids handling ability.

Each of the above noted Little Giant products is guaranteed to be in perfect condition when it leaves our factory. During the time periods and subject to the conditions hereinafter set forth, LITTLE GIANT PUMP COMPANY, subsidiary of Franklin Electric Company, Inc., will repair or replace to the original user or consumer any portion of your new LITTLE GIANT product which proves defective due to materials or workmanship of LITTLE GIANT. Contact your nearest authorized Little Giant service station for warranty service. At all times LITTLE GIANT shall have and possess the sole right and option to determine whether to repair or replace defective equipment, parts, or components. Damage due to lightning or conditions beyond the control of LITTLE GIANT is NOT COVERED BY THIS WARRANTY.

**WARRANTY PERIOD**

**PUMPS:** 24 months from date of purchase or 30 months from date of manufacture, whichever occurs first.

**LABOR, ETC. COSTS:** LITTLE GIANT shall IN NO EVENT be responsible or liable for the cost of field labor or other charges incurred by any customer in removing and/or affixing any LITTLE GIANT product, part or component thereof.

**THIS WARRANTY WILL NOT APPLY:**

1. to defects or malfunctions resulting from failure to properly install, operate, or maintain the unit in accordance with printed instructions provided
2. to failures resulting from abuse, accident or negligence
3. to normal maintenance services and the parts used in connection with such service
4. to units which are not installed in accordance with applicable local codes, ordinances and good trade practices
5. unit is used for purposes other than for what it was designed and manufactured
6. if pump exposed to but not limited to the following: sand, gravel, cement,

grease, plaster, mud, tar, hydrocarbons, or hydrocarbon derivatives (oil, gasoline, solvents, etc.) or other abrasive or corrosive substances

7. if pump has been used for continuous pumping of suitable liquids above 140°F
8. if cord cut off to a length less than three feet
9. if pump has been dismantled by customer. (Dealer only can dismantle pump for field service.)

**RETURNED OR REPLACED COMPONENTS:** Any item to be replaced under the Warranty must be returned to LITTLE GIANT at Oklahoma City, OK or such other place as LITTLE GIANT may designate, freight prepaid.

**PRODUCT IMPROVEMENTS:** Little Giant reserves the right to change or improve its products or any portions thereof without being obligated to provide such a change or improvement for units sold and/or shipped to such change or improvement.

**DISCLAIMER:** Any oral statements about the product made by the seller, the manufacturer, the representatives or any other parties, do not constitute warranties, shall not be relied upon by the user, and are not part of the contract for sale. Seller's and manufacturer's only obligation, and buyer's only remedy, shall be the replacement and/or repair by the manufacturer of the product as described above. Neither seller nor the manufacturer shall be liable for any injury, loss or damage, direct, incidental or consequential (including, but not limited to, incidental or consequential damages for lost profits, lost sales, injury to person or property, or any other incidental or consequential loss), arising out of the use or the inability to use the product, and the user agrees that no other remedy shall be available to it. Before using, the user shall determine the suitability of the product for his intended use, and user assumes all risk of liability whatsoever in connection therewith. The warranty and remedy described in this limited warranty is an EXCLUSIVE warranty and remedy and is IN LIEU OF any other warranty or remedy, expressed or implied, which other warranties and remedies are hereby expressly EXCLUDED, including but not limited to any implied warranty of MERCHANTABILITY OR FITNESS FOR A PARTICULAR PURPOSE. Some states do not allow the exclusive or limitation of incidental or consequential damages, so the above limitation or exclusion may not apply to you. This warranty gives you specific legal rights, and you may also have other rights which vary from state to state.

In the absence of other suitable proof of the purchase date, the effective date of this warranty will be based upon the date of manufacture plus two years. Direct all notices, etc., to: Service Department, LITTLE GIANT PUMP COMPANY, 3810 N. Tulsa, Oklahoma City, OK 73112.

**DETERMINATION OF UNIT DATE OF MANUFACTURE:** (9-87) month and year stamped on pump and/or serial number on pump nameplate coded to indicate year of manufacture.

For parts or repair, please contact .....1-888-572-9933  
For technical assistance, please contact .....1-888-956-0000

[www.LittleGiantPump.com](http://www.LittleGiantPump.com)  
[CustomerService-WTS@fele.com](mailto:CustomerService-WTS@fele.com)