

# Primetime Pump

The Primetime Pump is a high performance self-priming 316 stainless steel centrifugal pump. The pump is ideal for marine, industrial, agricultural or commercial applications where suction lift is required.

Primetime features all 316 stainless steel components for superior corrosion resistance when pumping sea water or chemical compounds. A carbon/ceramic/Viton mechanical shaft seal is standard. Ports are 3/4" NPT with a 1/8" NPT fill port. The Primetime model is capable of 12 foot suction lift (3450 rpm). Marine ignition protected motors (ISO 8846).

## SPECIFICATIONS:

- Flow ..... Up to 21 GPM
- Head Feet ..... Up to 23'
- Housing ..... 316 Stainless Steel (Investment Cast)
- Cover ..... 316 Stainless Steel
- Impeller ..... 316 Stainless Steel Semi-Open
- Wearplate ..... 316 Stainless Steel
- Mechanical Seal ..... Carbon / Ceramic / Viton Bellows
- O-ring/Flapper ..... Viton
- Weight ..... 16 lbs



**Motor Options (All ISO 8846)**

- 115 VAC 60hz
- 230 VAC 50/60 hz
- Close Coupled 12 VDC
- Close Coupled 24 VDC

**Port Sizes**

- 3/4" X 3/4" NPT
- 1/8 NPT Fill Plug

**Mechanical Seal**

- Carbon/Ceramic/Viton

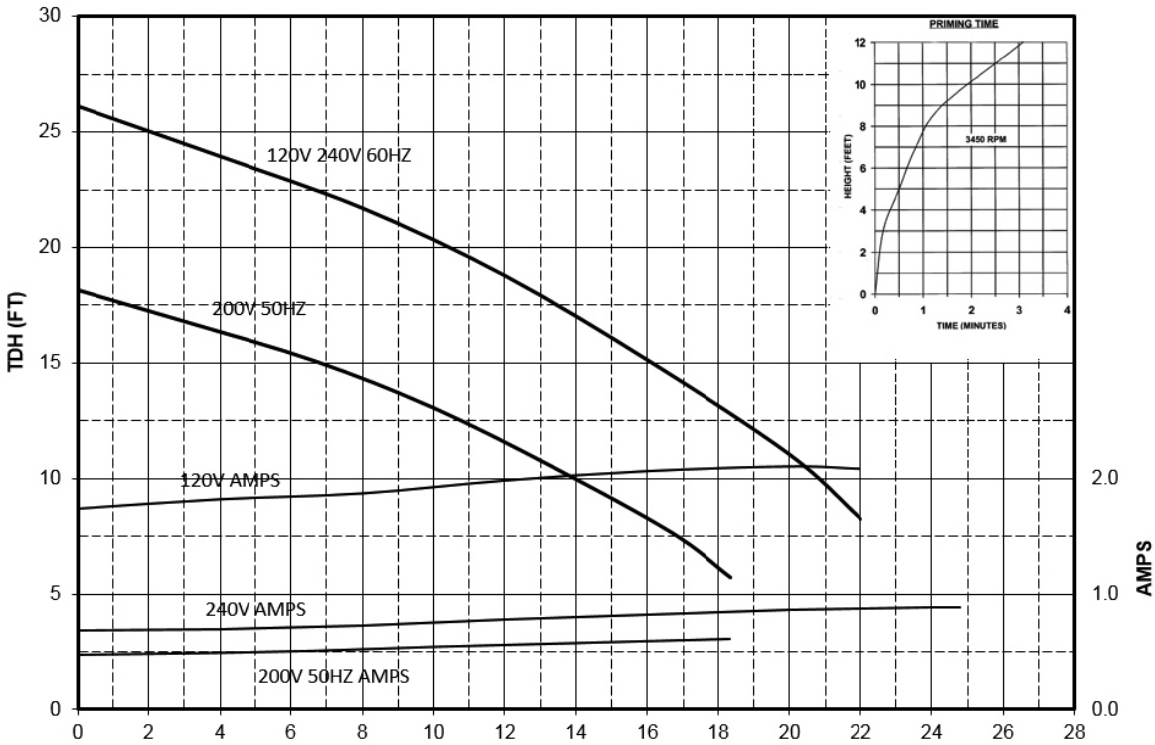

MODEL: PRIMETIME  
PORTS: 3/4" X 3/4" NPT  
MOTOR: AC & DC

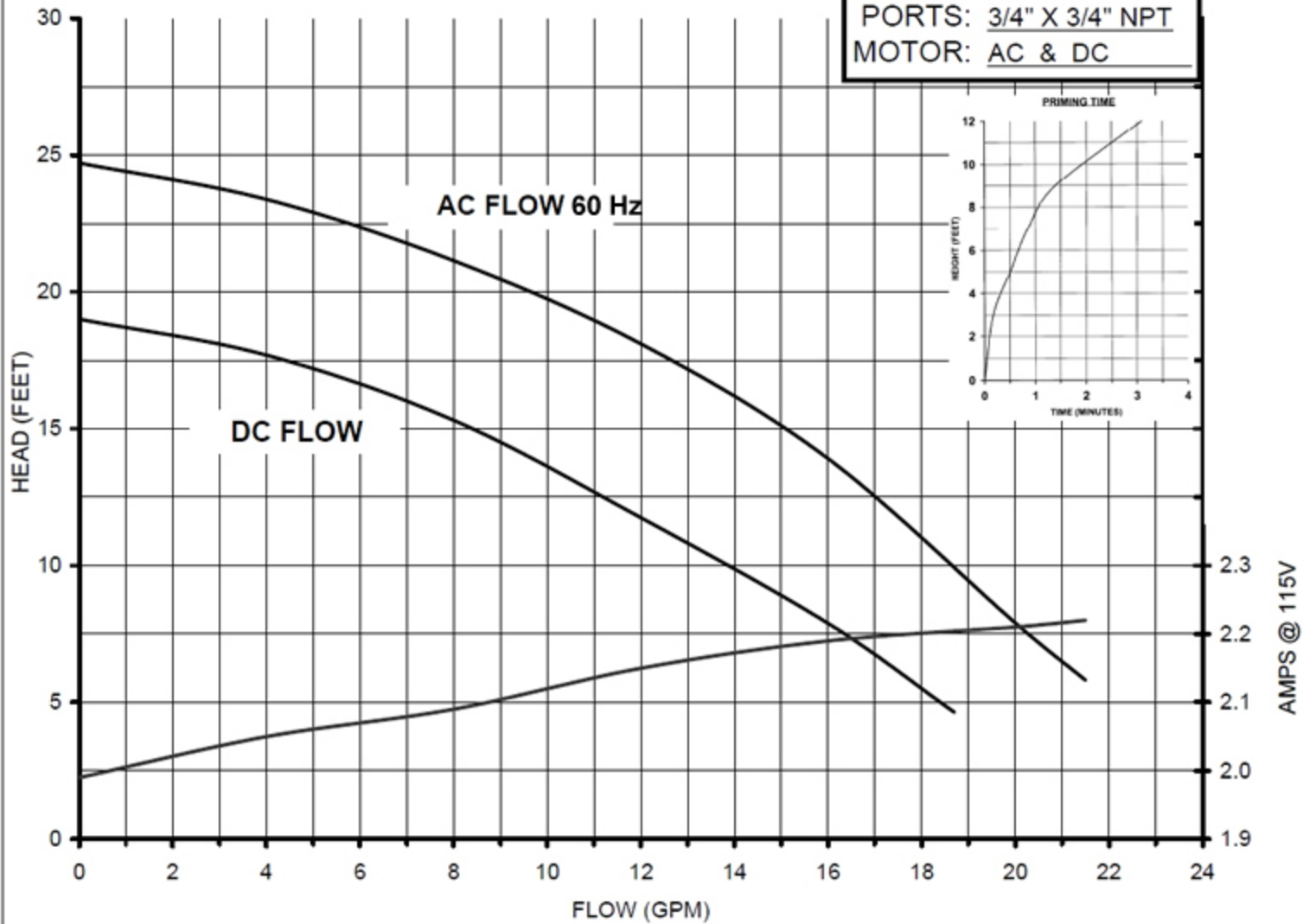

# Primetime Pump

12 and 24 VDC Dimensions

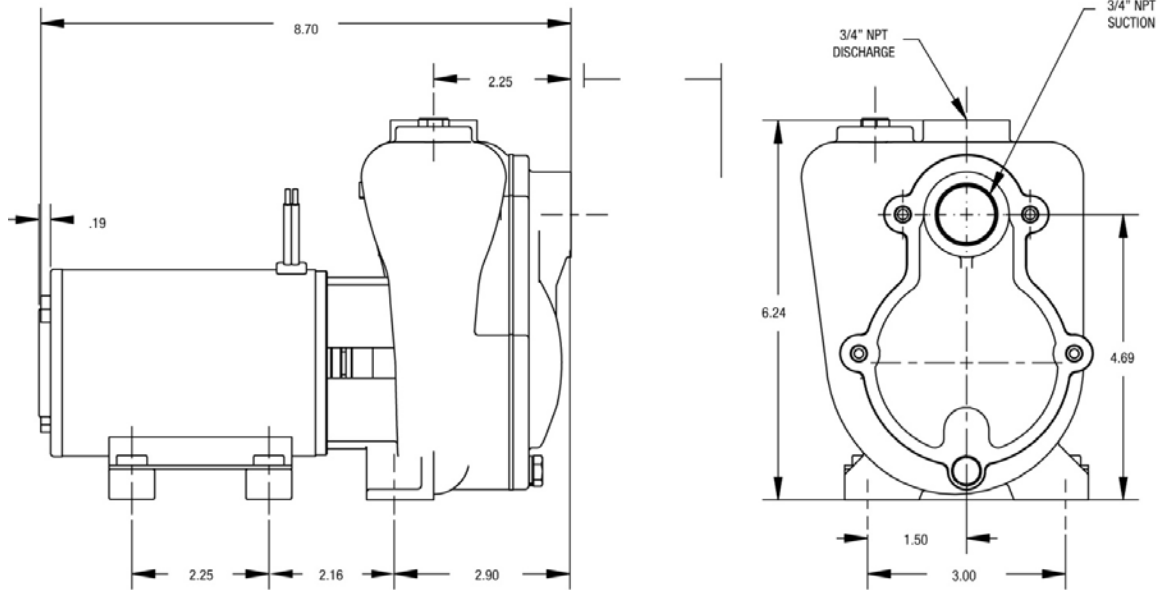

115/230 VAC Dimensions

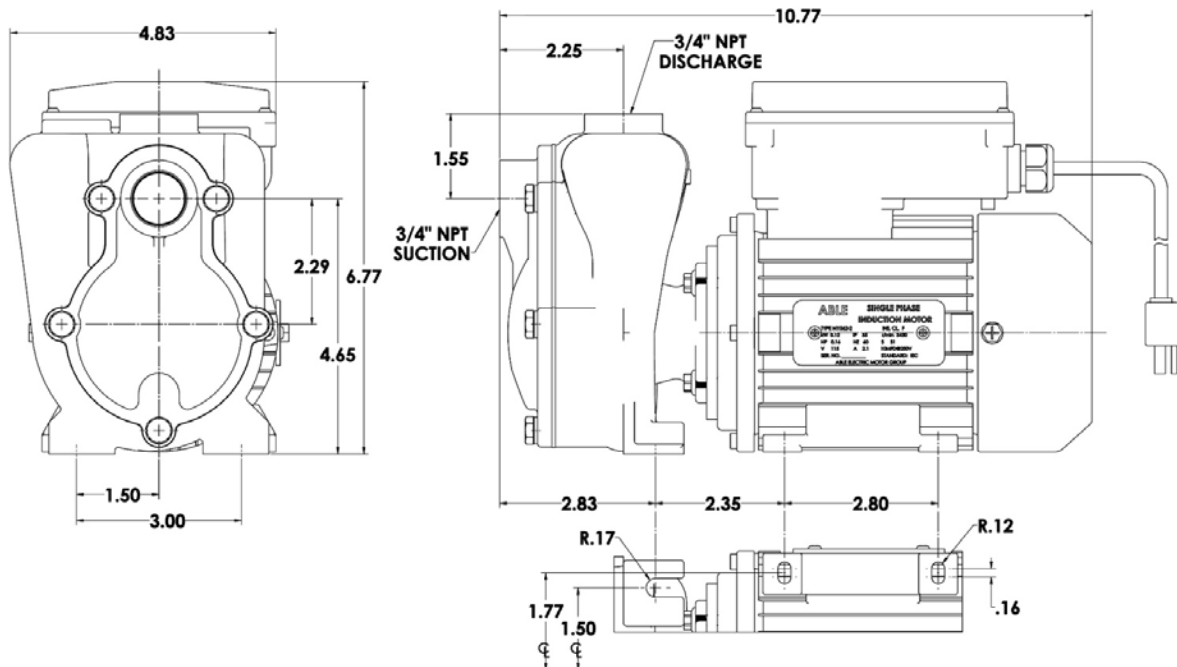

# Primetime Pump

## PRIMETIME STAINLESS STEEL CENTRIFUGAL PUMP INSTALLATION, OPERATION, AND REPAIR MANUAL

The PRIMETIME is a high performance self-priming stainless steel centrifugal pump. The pump is ideal for marine, industrial, agricultural or commercial applications where suction lift is required. The model features all 316 stainless steel components for superior corrosion resistance when pumping sea water or chemical compounds. A carbon/ceramic/viton mechanical seal is standard. Ports are 3/4" with 1/8" NPT fill port. The PRIMETIME model is capable of 12 foot section lift (3450 rpm). Weight 16 lbs



### **GENERAL SAFETY INFORMATION:**

**THE FOLLOWING WARNINGS ARE USED TO NOTIFY AND ADVISE THE USER OF THIS PRODUCT OF PROCEDURES THAT MAY BE DANGEROUS TO THE USER OR RESULT IN DAMAGE TO THE PRODUCT.**

**THIS BULLETIN MUST BE READ COMPLETELY BEFORE INSTALLING, OPERATING, OR SERVICING THE PUMP.**

- **DO NOT** perform service or maintenance when the pumping system is pressurized. Injury or death may occur.
- **DO NOT** operate the pump in a manner that it was not intended to be used.
- **DO NOT** mount the pump such that high piping loads exist on the pump flanges, or in a rigid piping system that does not allow the pipe to expand and cause the pump to be strained.
- **DO NOT** use bronze or brass fittings.
- **DO NOT** continue to operate the pumping system when a known leak exists.
- **DO NOT** continue to operate the pump when unusual noise or vibration occurs.
- **DO NOT** operate beyond the pressure or temperature limits stated in the product literature.
- **DO NOT** allow severe temperature changes to occur in a short time period within the pumping system.

---

### **INSTALLATION:**

For optimum performance, place the pump as close to the liquid as possible to minimize suction lift. For best results, the pump should be installed no more than 10 feet above the liquid supply. The motor is splash resistant, not submersible, and should be located in a dry environment.

## PIPING / MOUNTING:

The pump inlet and outlet has 3/4" pipe connections. Use pipe sealant on the threads and other connections. The base does not require direct mounting if one of the pipe flanges is rigid mounted. Do not rigid mount both the flanges and the base to avoid mounting tolerances that may distort the motor base. Install the pump with the shaft in a horizontal direction. Never install the pump vertical with the motor below the pump.

## ELECTRICAL:

The motor must be protected from over current by using a fuse or circuit breaker (see chart below for correct protection). The proper minimum wire size is stated for each voltage application. Make sure that the pump has the proper voltage rating to match the installation power. Do not use or install if the voltage on the label is different than the installation. All wire connections must be secure and sealed to protect against arcing. Pump must be grounded and bonded. Follow all local installation codes.

MOTOR VOLTAGE ON NAME PLATE	FUSE/CB AMPS	WIRE SIZE AWG
115 VAC	2.0	18
230 VAC	1.1	18
12 VDC	15.0	14
24 VDC	10.0	16

NOTE: Dual volt motors on older versions shipped set to low (115V) voltage. To change, open conduit cover and set to high (230V) voltage then cut plug off of cord.

## OPERATION:

The PRIMETIME is a self-priming centrifugal pump and only requires priming prior to its initial startup. This is accomplished by removing the priming plug and filling the chamber with liquid. The pump will retain sufficient liquid for self-priming thereafter. Check chamber for liquid if the pump has not been used for a period of time.

## REPAIR AND MAINTENANCE:

DC motor brush life expectancy is 6,000 hours total brush life. The motor is not rebuildable after the brushes have worn to the limits.

The pump has a carbon/ceramic seal that may last several thousand hours based upon the application. If the motor is replaced, the mechanical shaft seal should also be replaced. A seal that leaks will show leakage through the slot between the pump housing and the motor. Extreme leakage may damage the motor bearings and contaminate the inside of the motor.

ITEM NO.	PART NUMBER	DESCRIPTION	MATERIAL	QTY.
1	39294	HOUSING	316 STAINLESS STEEL	1
2	21255	PIPE PLUG 1/8" NPT	316 STAINLESS STEEL	1
3	39827	HEX HEAD CAP SCREW M5 X 0.8	304 STAINLESS STEEL	4
4		ELECTRIC MOTOR	ALUMINUM SHELL	1
5	35039	CAPSCREW 1/4-20X5/8	316 STAINLESS STEEL	5
6	33564	LOCKWASHER 1/2"	304 STAINLESS STEEL	5
7	35024	COVER	316 STAINLESS STEEL	1
8	35025	GASKET	VITON	1
9	35027	SNAP RING	316 STAINLESS STEEL	1
10	35026	WEAR PLATE	316 STAINLESS STEEL	1
11	28766	ACORN NUT	316 STAINLESS STEEL	1
12	34033	IMPELLER	316 STAINLESS STEEL	1
13	36863	SEAL ASSEMBLY	VITON/SC	1
14	35947	V RING	VITON	1

## DISASSEMBLY:

1. Remove five cover screws and remove the cover and gasket.
2. Remove snap ring and wear plate.
3. Secure the impeller and remove the impeller lock nut. Pull the impeller straight out of the motor shaft.
4. Remove the seal-rotating portion by pulling the seal off by hand.
5. Remove the two capscrews that hold the pump housing onto the motor. Remove the pump housing and push the seal seat out using a screwdriver.

## INSPECT PUMP PARTS:

Check the seal for dry run wear or damage. Always replace the mechanical seal if worn. Check the motor shaft for wear at the secondary sealing surface from the mechanical seal. If worn, replace the motor. Check the motor bearings by rotating the motor by hand. If the shaft rotation is not smooth or has radial/axial endplay, replace the motor. Check the impeller running surface between the impeller and cover. If the surfaces are worn or irregular, replace each item. Clean the parts that are to be reused using a solvent or mild cleaner. Remove abrasive material.

## RE-ASSEMBLY:

1. Press the new seal seat into the pump housing. A light lubricant may be used to aid the assembly. Install the pump housing onto the motor and fasten the screws through the motor.
2. Install the rotating portion of the mechanical seal by sliding the seal over the motor shaft. Do not use any lubricant.
3. Place the impeller onto the shaft over the "D" drive against the shoulder and tighten the impeller lock nut until the impeller is securely shouldered on the motor shaft. Thread locking grade Loctite should be used to secure the nut.
4. Replace wear plate and snap ring. Check the pump for internal interference by rotating the impeller. The pump should rotate freely with only seal friction.
5. Install the gasket and cover onto housing and fasten with capscrews and lockwashers.

