

Replacement Motor Cartridge Installation

To Remove:

Block off thru-hull before removing motor cartridge to avoid water from entering the bilge. Squeeze tabs and rotate the motor clockwise until it stops. Lift motor cartridge out.

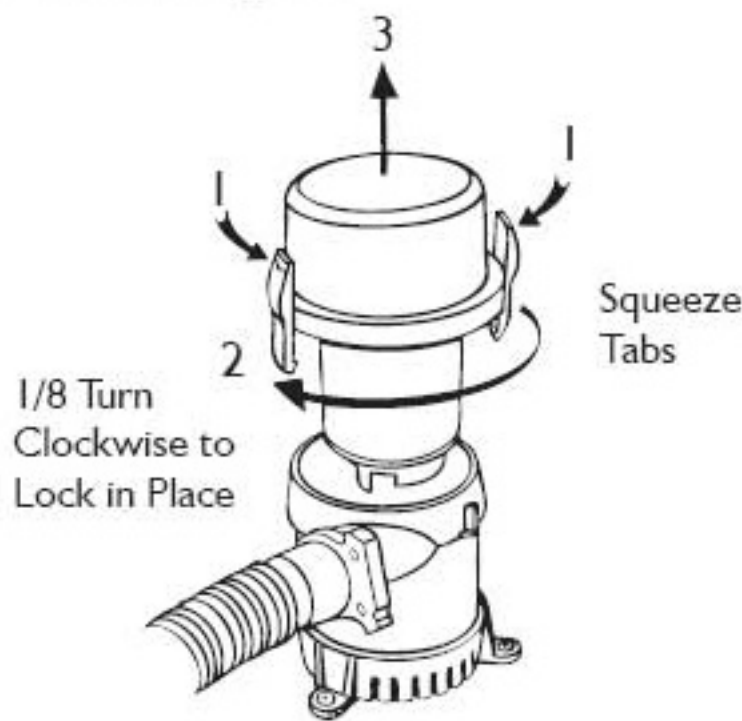

To Install:

Insert new motor cartridge making sure both tabs latch in place and then turn counter clockwise until it locks.

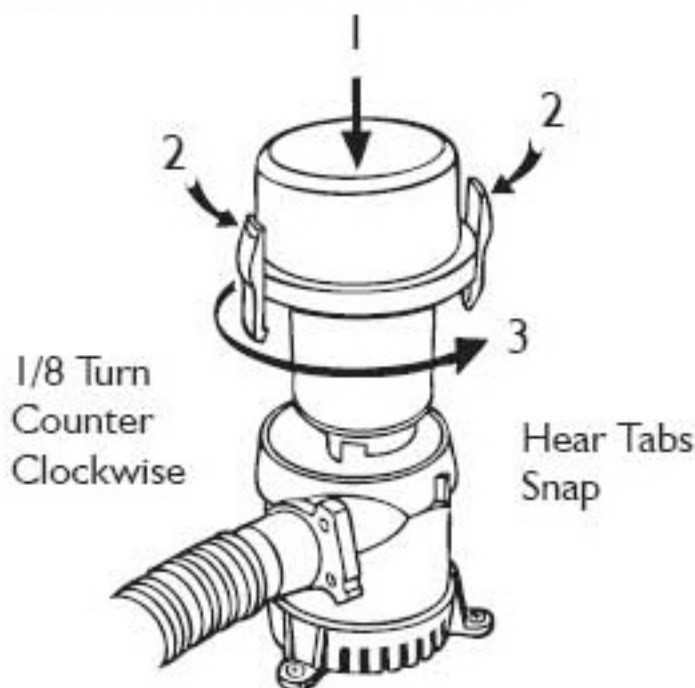

Electrical

Rule #49 On-Off Panel Switch

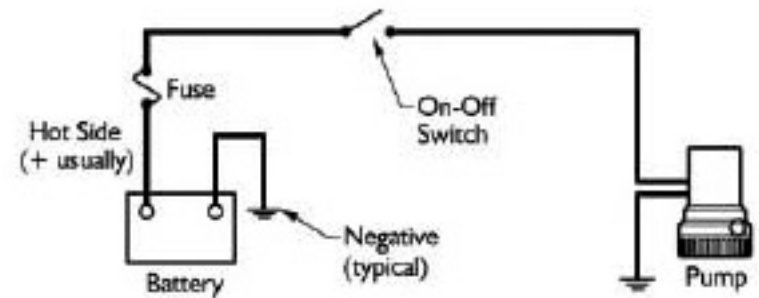

- 1.) Disconnect power source from the old pump, either at the battery or the fuse panel.
- 2.) Cut the old wires connecting the pump to the positive and negative source.
- 3.) Using the proper wire connectors, marine grade sealant, and heat shrink tubing, connect the new brown wire from the pump to the existing brown wire connected to the positive source.
- 4.) Using the proper wire connectors, marine grade sealant, and heat shrink tubing, connect the new black wire from the pump to the existing black wire connected to the negative source.

Specifications

MODEL	Output Open Flow (GPH) (LPH)	Output 3.35' (GPH) (LPH)	Output 6.7' (GPH) (LPH)	Fuse Size
25DR 12 VOLTS	500 (1890)	360 (1363)	260 (984)	2.5A
20RR 12 VOLTS	700 (2650)	540 (2044)	370 (1401)	5A
27DR 12 VOLTS	1100 (4160)	860 (3255)	600 (2271)	6

NOTE: Output is based on 10 hour break-in period and at 13.6 v (12v models) or 27.2 v (24 v models).