

SERVICE PART NO.	COMPONENT PART NO'S	NO. REQ'D
11458	11454	1
BODY	413	2
10914	10913	1
COVER	6333-G	1
10927	10523	1
SEAL & SEAT	10926	1
MAJOR REPAIR KIT # 12300 ©		
MINOR REPAIR KIT # 10656 ©		

- 11454 1 REQ'D
- 4257 1 REQ'D
- 4259 1 REQ'D
- 11456 1 REQ'D
- 11515 1 REQ'D
- MODIFIED
- Nº 9 WOODRUFF KEY

- 10609 2 REQ'D
- 413 2 REQ'D
- 10926 1 REQ'D
- 18743 1 REQ'D Ⓞ
- 4258 3 REQ'D ⓑ
- 9959 2 REQ'D
- 6333-G 1 REQ'D

THIS DIA. MUST BE CONCENTRIC WITH .6245/.6250 DIA. WITHIN .002 FIR

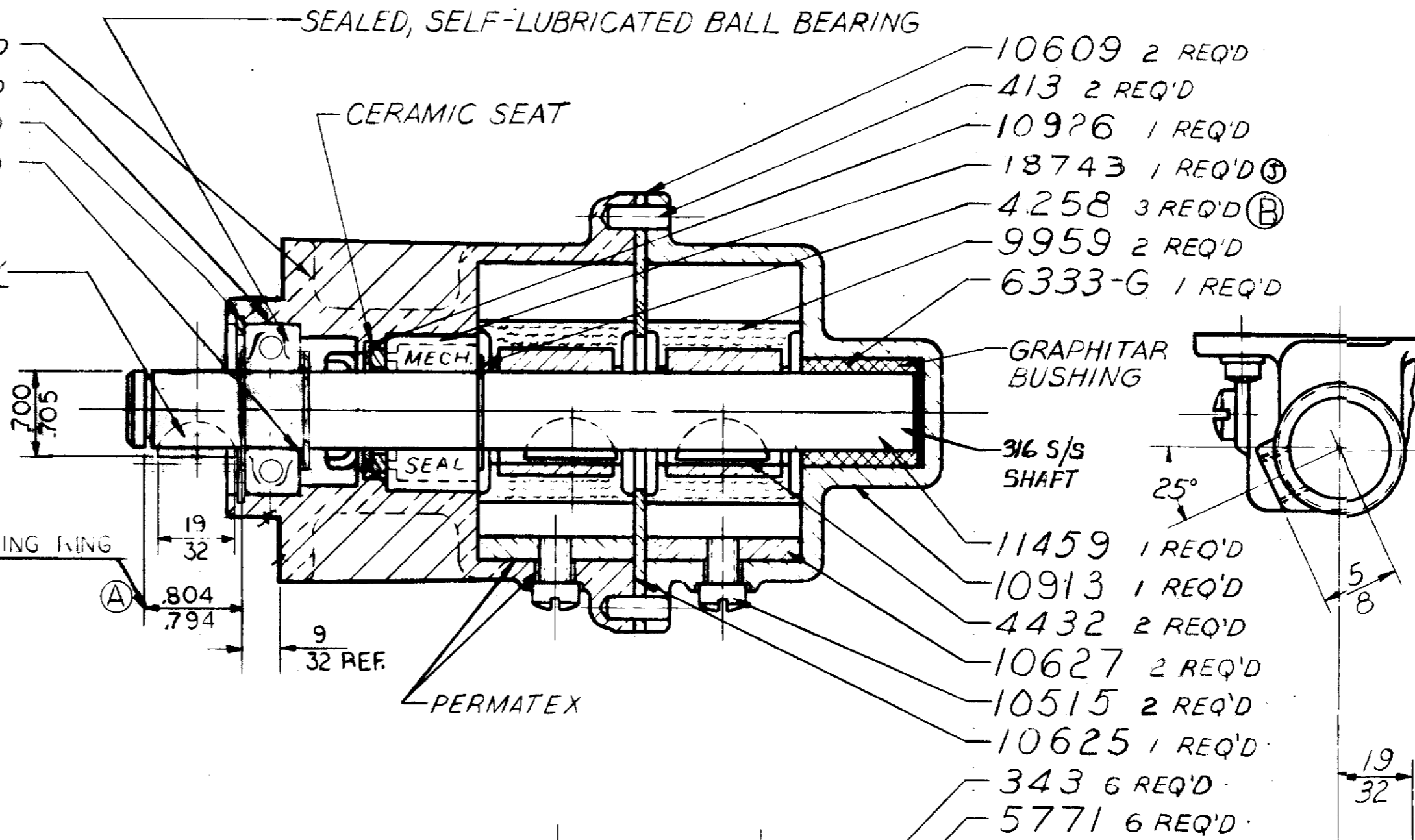
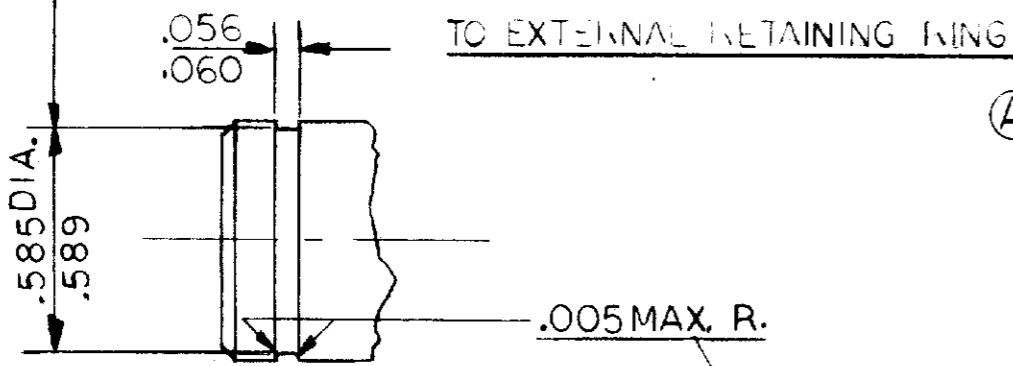

STAMP PUMP ASSEMBLY NO. D-60 AND DATE CODE ON TAG, ATTACH WITH SCREW

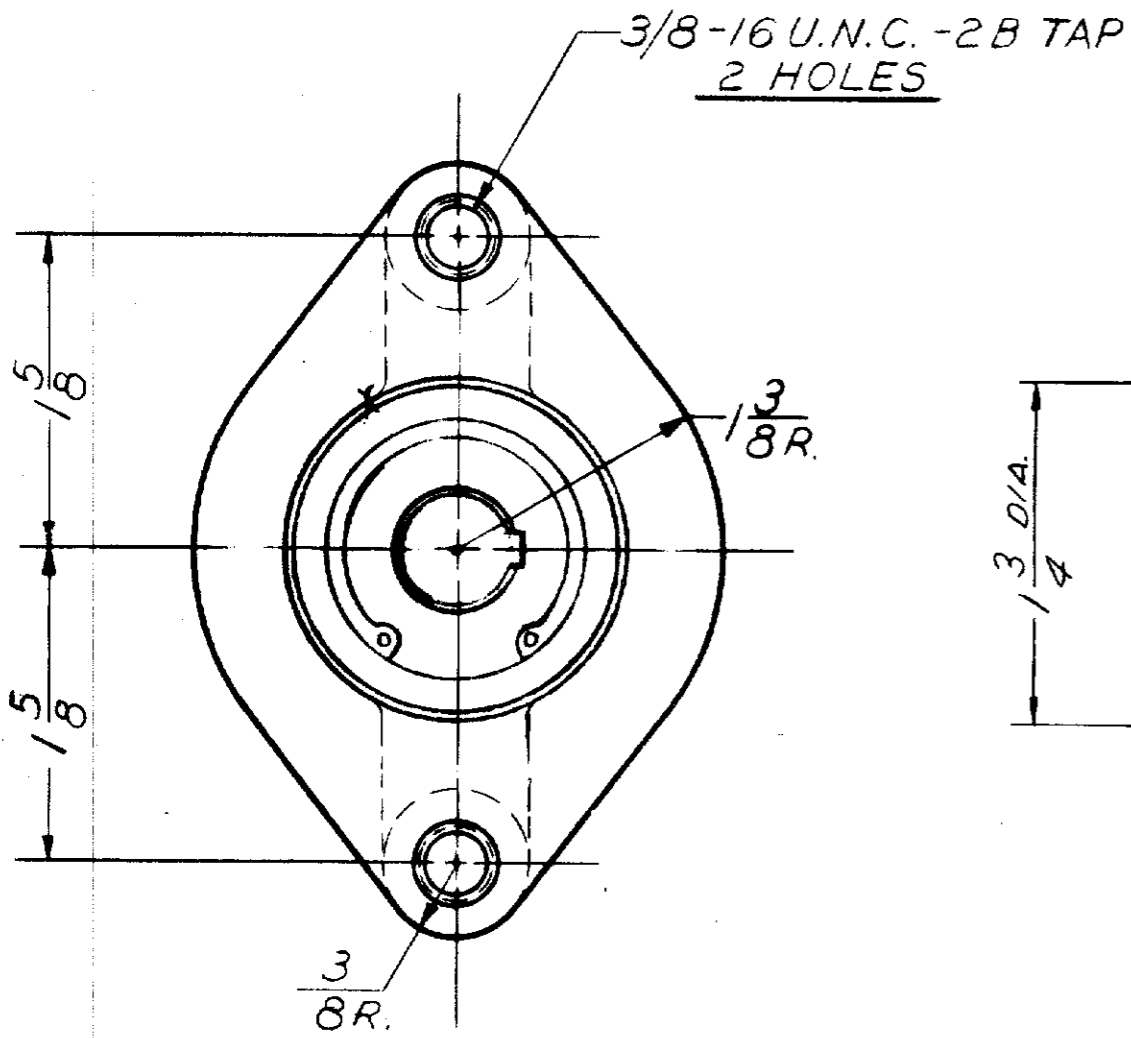

CAPACITY  
20.0 G.P.M. @ 3600 R.P.M., EACH PORT

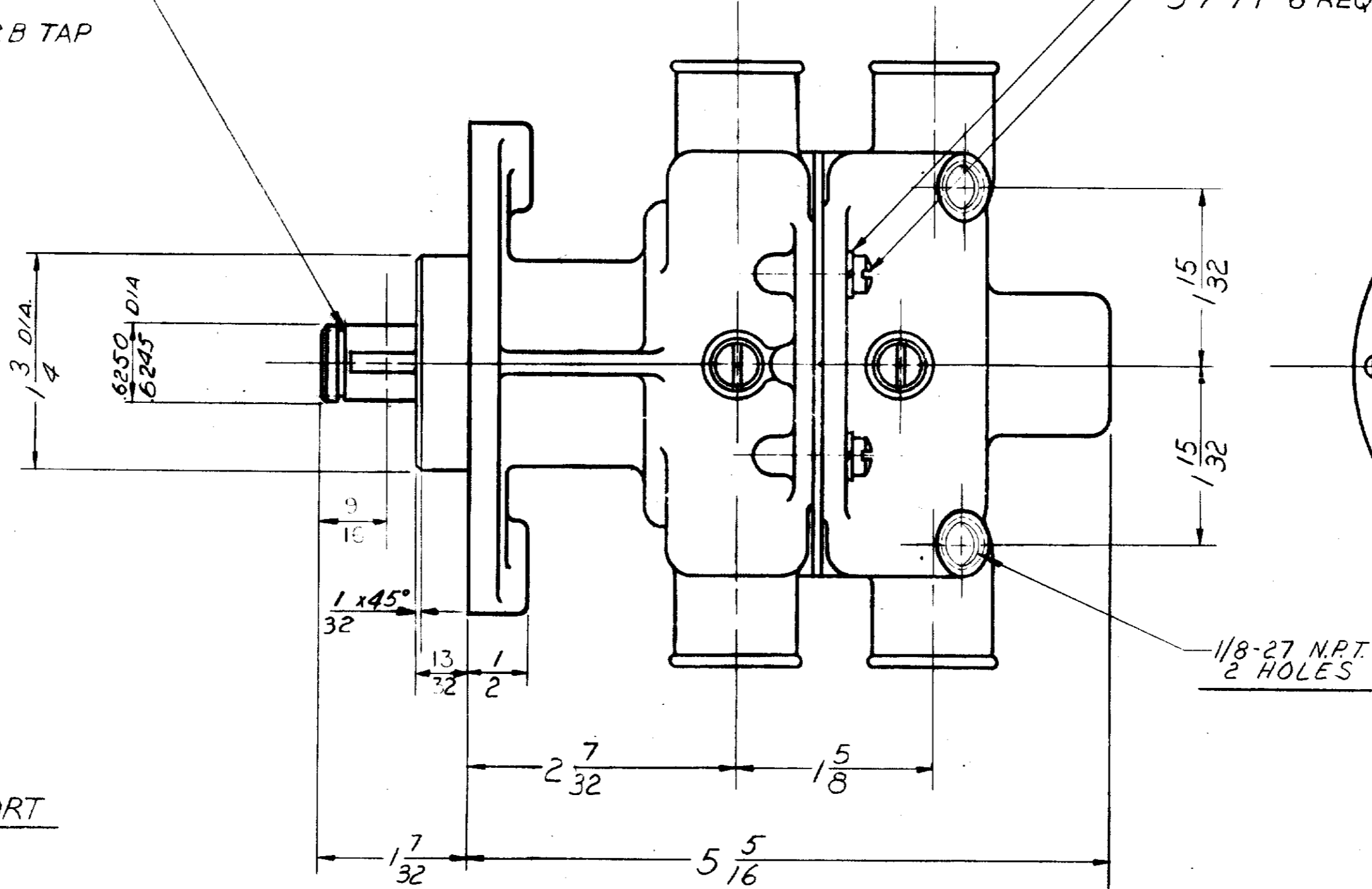

CURVE NO. 72010 & 72011

CHRYSLER CORP.  
MARINE DIV.  
Nº 2847630

- Ⓞ FOR SERVICE:
- PACKAGE THIS PUMP ASSEMBLY IN A
- # Y BOX 1 REQ'D
- # 2 JIFFY BAG 1 REQ'D
- # 12209 LABEL 1 REQ'D
- ⓑ # 13472 SURVICE BULLETIN 1 REQ'D

FLOW CURVE REF. G-30

J SEAL WAS 10523 KB 8-16-89

NO.	DESCRIPTION	DATE
I	ADDED TAG NO. 13285	
H	NO. 13472 SURVICE BULLETIN ADDED	RI 2-1-82
G	PACKAGING NOTE ADDED	RM 7-31-78
F	10656 KIT REVISED	RM 10-20-74
E	12300 KIT ADDED	RM 10-20-74
D	NOTES ADDED	RM 7/24/73
C	MAJOR SERVICE KIT ADDED	RM 4-24-72
B	WAS 2 REQ'D	T.J. 10-27-69
A	WAS 7/8 TO INNER RACE*	P.J. 5-16-69

DO NOT SCALE DRAWING  
PLUS OR MINUS .005 ALLOWED ON FRACTIONAL DIMENSIONS. ALL HOLES AND SHARP CORNERS TO BE BURRED .005 TO .010. CORNERS AND FILLETS TO BE 1/8". UNLESS OTHERWISE SPECIFIED.

**SHERWOOD**  
A DIVISION OF HYPRO CORPORATION  
8831 E. JEFFERSON AVE. • DETROIT, MICHIGAN 48207

**IMPELLER PUMP ASSY** SEE DETAILS

SCALE FULL

DRAWN B.P. DATE 6-18-68

CHECKED A.V.B. DATE 6-28-68

APPROVED REF. # R-10925-6

BARE NO. D-60

PROJECT NO. C-70