

ITEM NO.	PART NUMBER	DESCRIPTION	QTY.
1	12441	SHAFT, RUBBER IMP.	1
2	12442	COUPLING - DRIVE SHAFT	1
3	12211	BALL BEARING	2
4	12210	BODY - BRASS	1
5	10514C	LIP SEAL	1
6	04432	WOODRUFF KEY	1
7	10072	CAM	1
8	09959	RUBBER IMPELLER	1
9	19995	SCREW 1/4-20 ROUND HD	1
10	19996	CAM WASHER	1
11	11360	GASKET - FIBER	1
12	12220	COVER - BRASS	1
13	12710	LOCKWASHER	4
14	19297	1/4-20 X 1/2 HHCS	4
15	18388	PLUG - PLASTIC	2

NOTES:

1. APPLY AGS SIL-GLYDE TO SEAL LIP PRIOR TO SHAFT INSTALLATION, ITEM 5.
2. APPLY BEAD OF PERMATEX AROUND THREADED HOLE IN CAM PRIOR TO ASSEMBLY, ITEM 7.
3. USE COOLANT OR SILICONE TO AID IN INSTALLATION OF RUBBER IMPELLER, ITEM 8.
4. TEST PUMP WITH VALVE OPEN FOR ONE MINUTE THEN PRESSURIZE PUMP TO 20 - 30 PSI, TO CHECK LIP SEAL FOR LEAKS.
5. STAMP "F85" & "DATE CODE" ON COVER, BEFORE COVER IS ASSEMBLED ON PUMP, ITEM 12

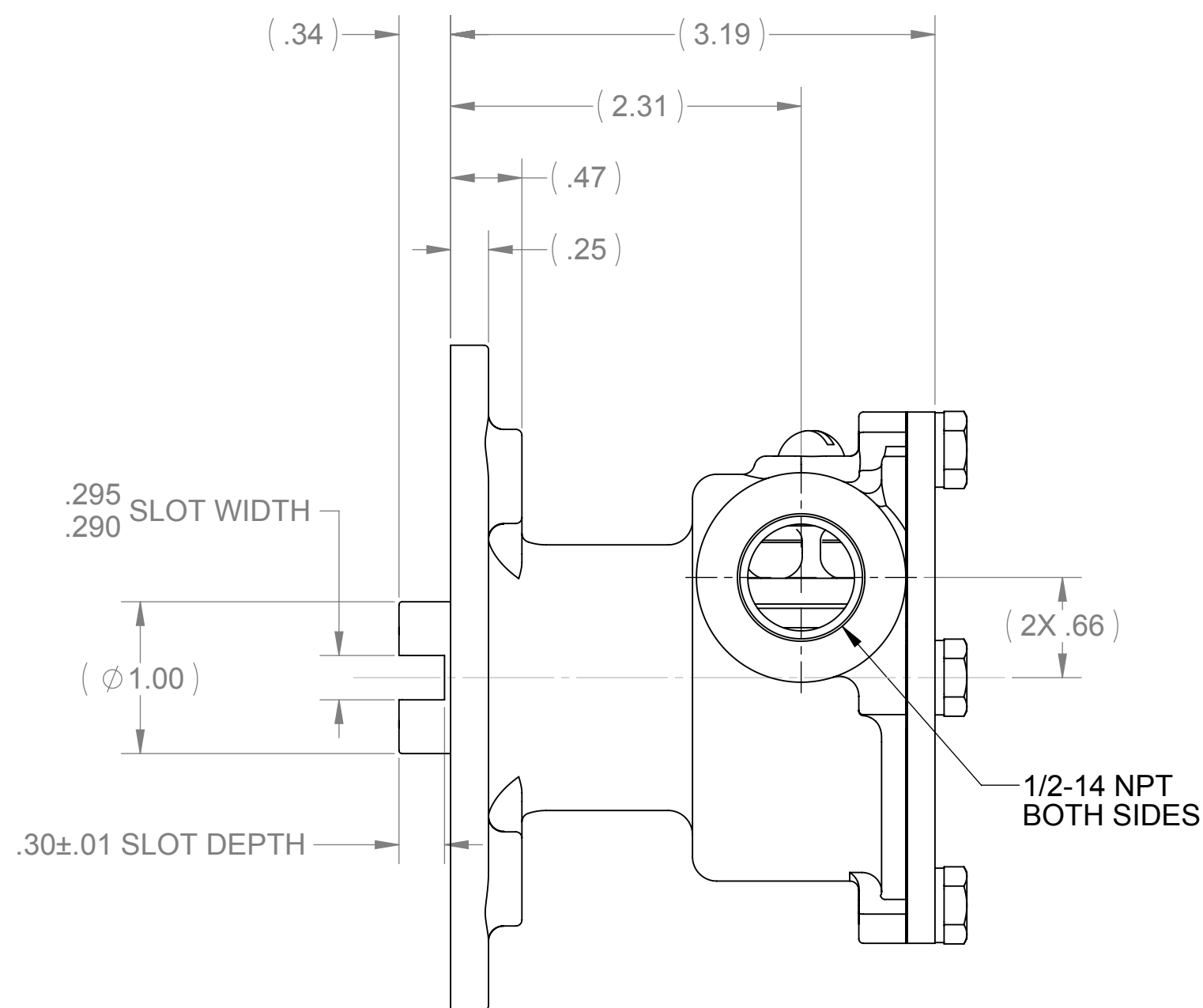
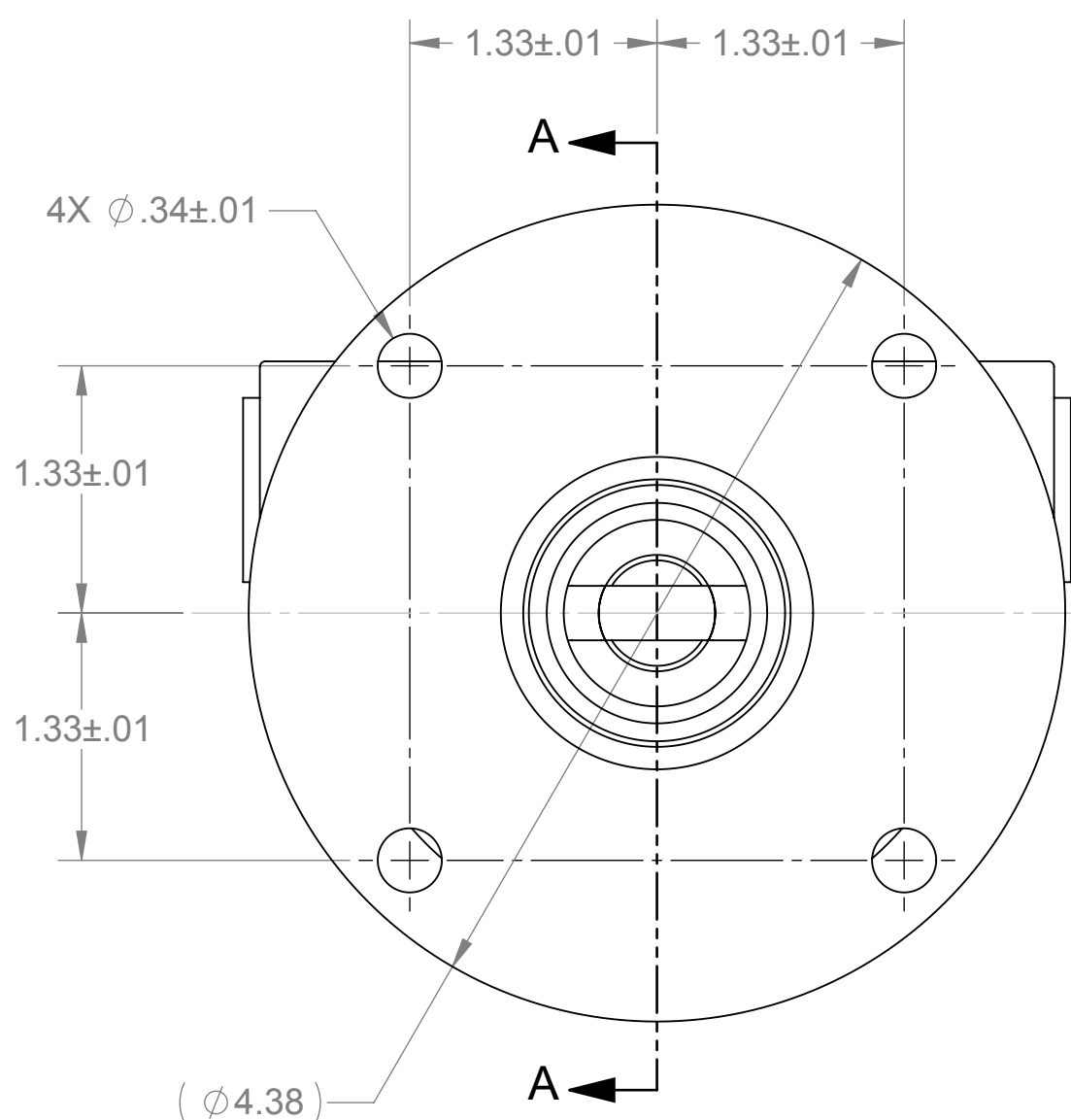
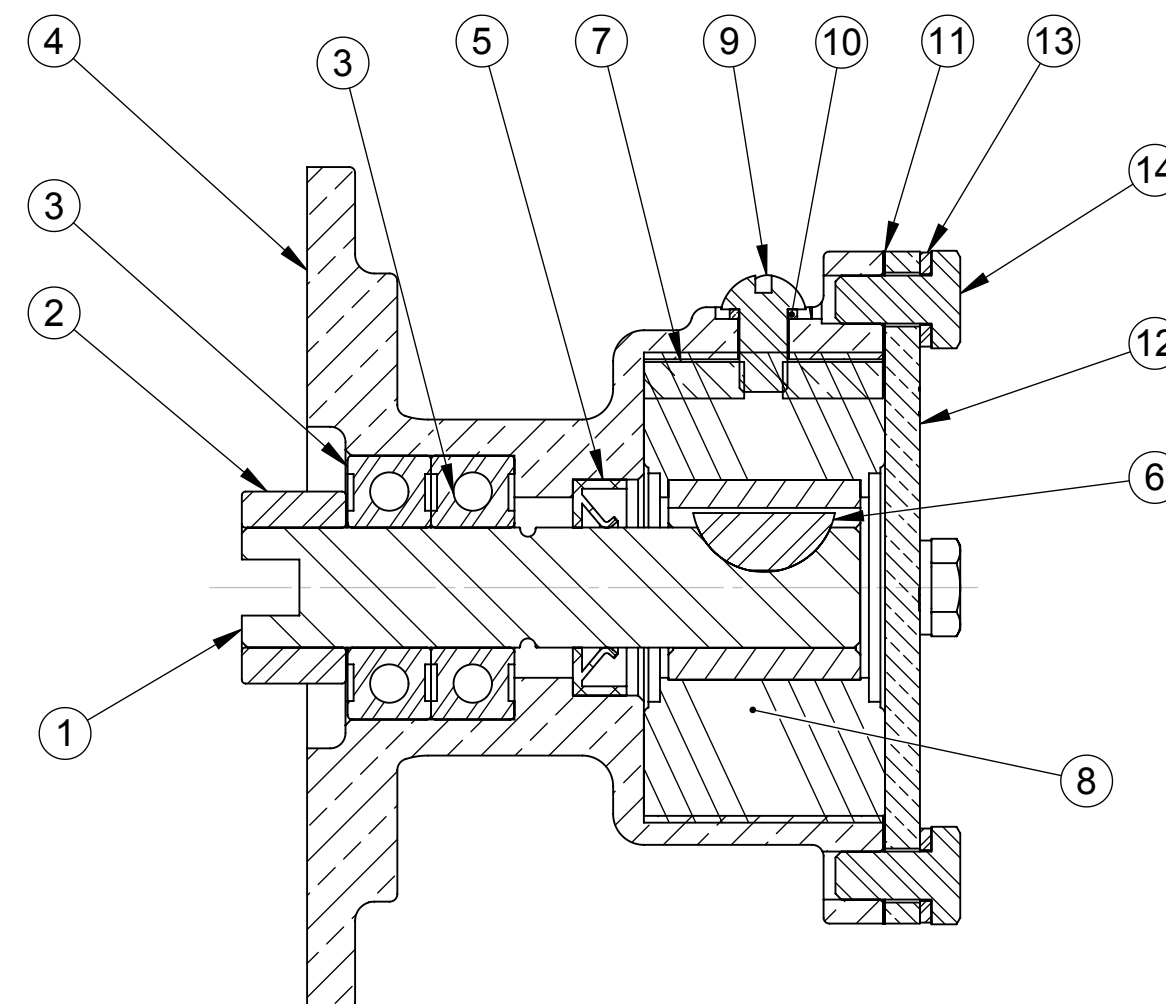

SECTION A-A

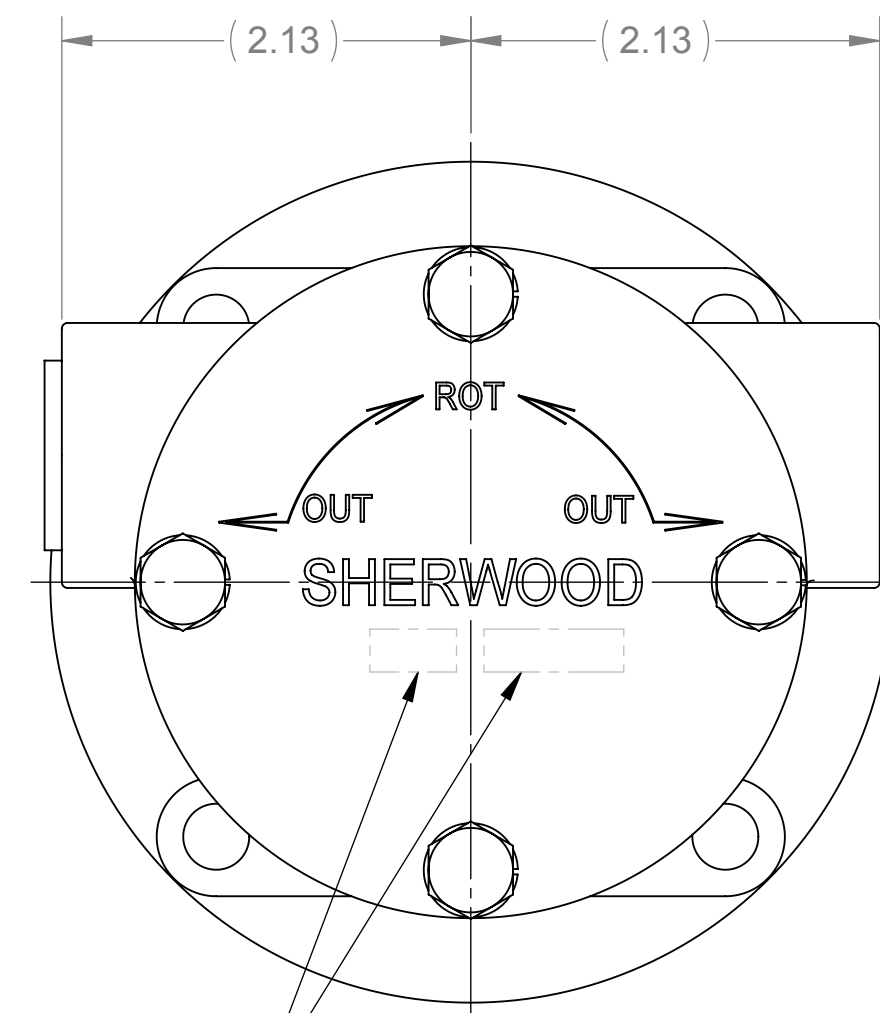

STAMP "F85" & "DATE CODE"
SEE NOTE 5

<p>SHERWOOD A Div. of Hypro Corporation A PENTAIR COMPANY 375 Fifth Avenue NW, New Brighton, MN 55112, (651) 766-6300</p>		REPLACES PART NO.	REV.
		DWG BY: TJ	DATE: 10/28/1971
DRAWING BASED ON ASME Y14.5M-1994		DO NOT SCALE PRINT	SIZE C
THIRD ANGLE PROJECTION	SCALE 1:1	SHEET NUMBER 1 OF 1	APPROVED BY: RBM DATE: 11/3/1971
PART DESCRIPTION			THIS DRAWING IS THE PROPERTY OF HYPRO, AND WITHOUT WRITTEN AUTHORIZATION, MUST NOT BE COPIED OR COMMUNICATED
RUBBER IMPELLER PUMP ASSY			PART NUMBER F85 REV. T

T	6675	UPDATED NOTES, REDRAWN	PEB	2/12/2008
REV.	ECN	REVISION DESCRIPTION	CHKD	DATE