

PARTS LIST

ITEM	PART NO.	DESCRIPTION	REQ'D
1	19570	SHAFT	1
2	15055	PULLEY ASSEMBLY	1
3	4258	RET. RING EXT.	3
4	4259	RET. RING INT.	2
5	13285	TAG	1
6	12314	MECH SEAL	1
7	12256	SEAL SEAT	1
8	12211	BALL BEARING	2
9	12710	1/4 LIGHT LCK. WASHER	3
10	12857	CAPSCREW 1/4-20x7/8	3
11	12856	END PLATE	1
12	10515	SCREW 1/4-20x3/8	1
13	18314	CAM (230)	1
14	15000	IMPELLER	1
15	17684	HOUSING	1
16	4432	Nº 9 WOODRUFF KEY	1
17	4264	THRUST WASHER	1
18	12231	O RING	1
19	12855	GASKET	1
20	5133	SPACER BRG	1
21	12227	BODY	1
22	17659	CARTON	1
23	12209	LABEL	1
24	17653	JIFFY BAG Nº 5	1
25			1
26			1

G151

SERVICE KIT		
KIT	PART Nº	ITEM Nº'S
SEAL AND SEAT	12859	6 (I) & 7 (I)
MAJOR REPAIR KIT #		
MINOR REPAIR KIT # 15979		

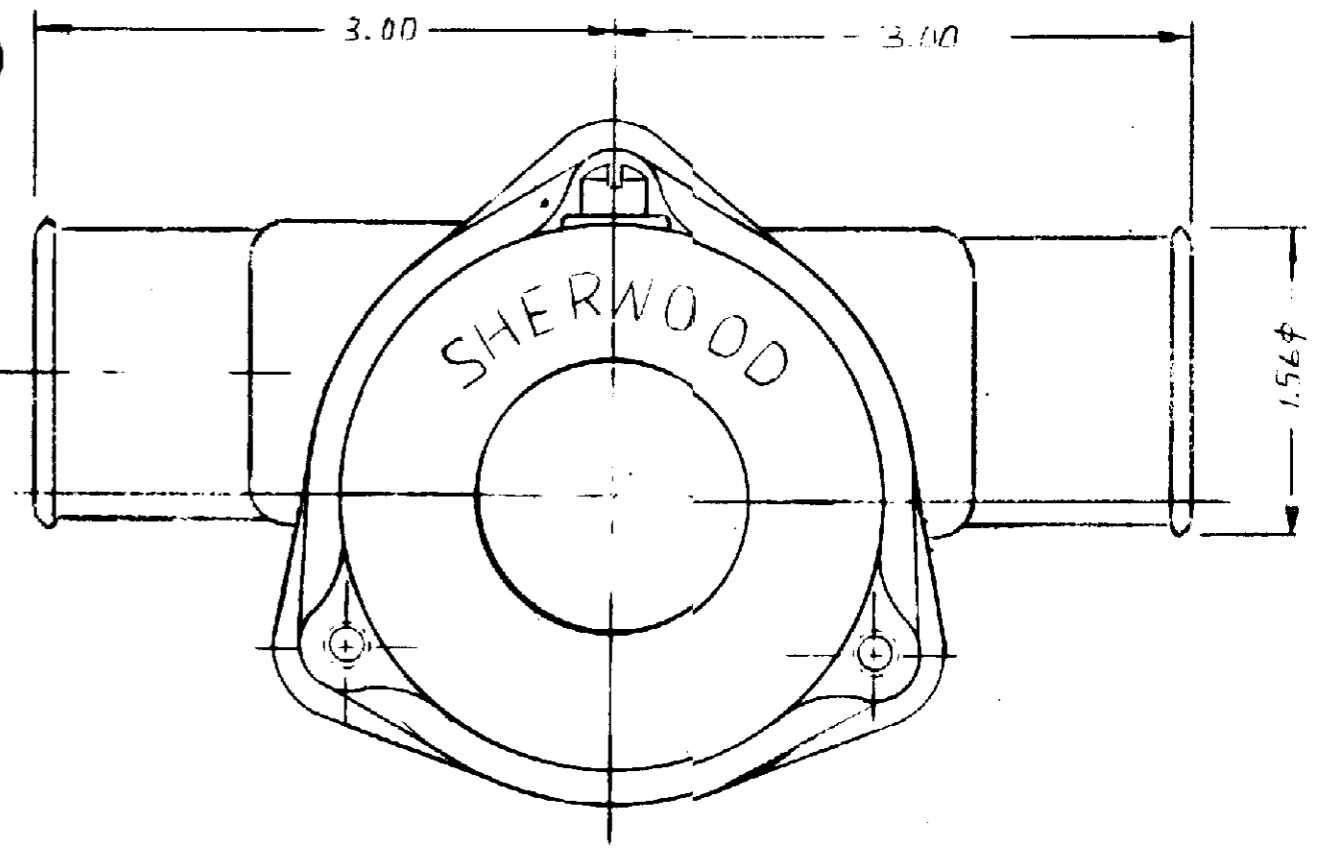
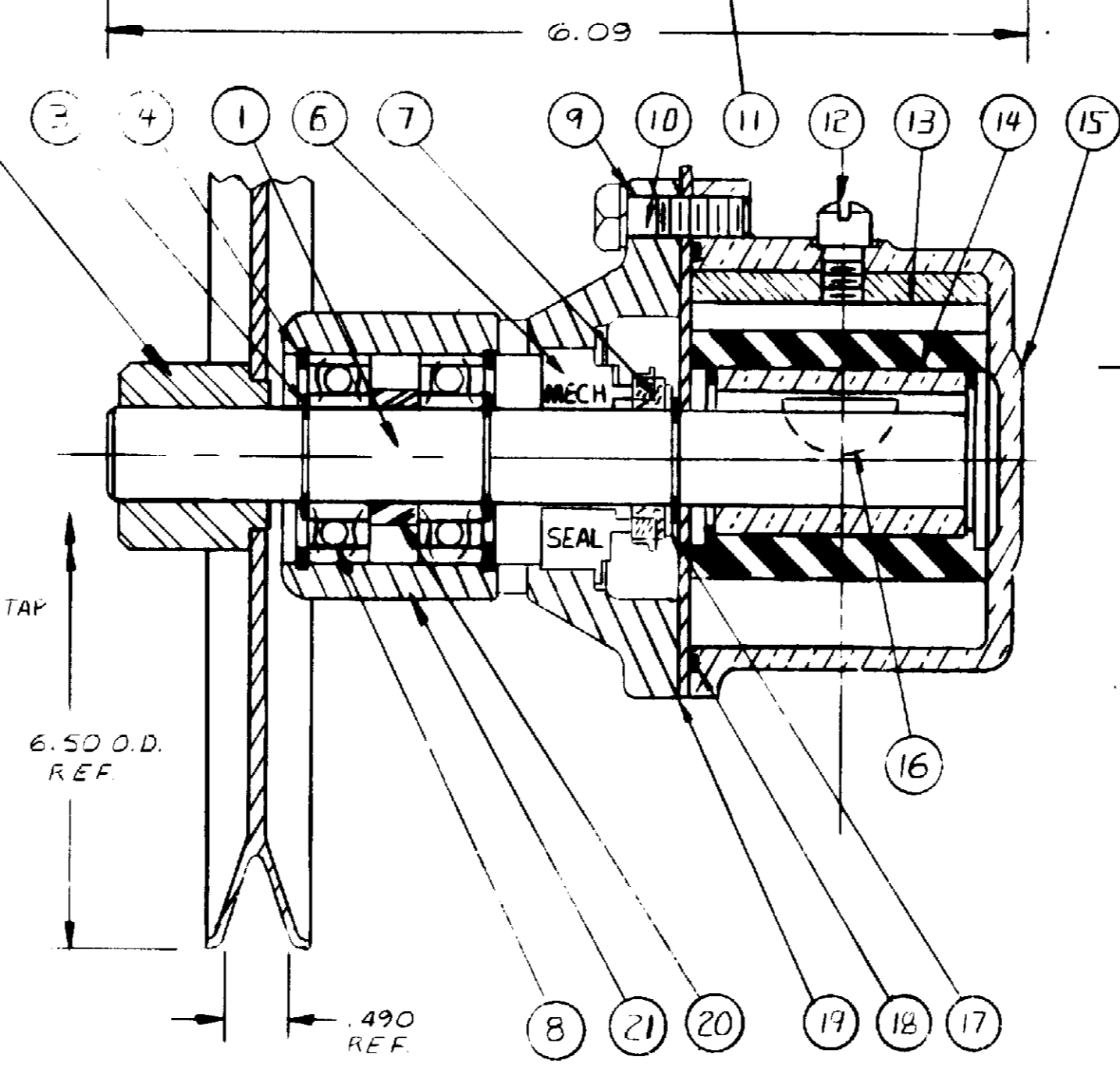
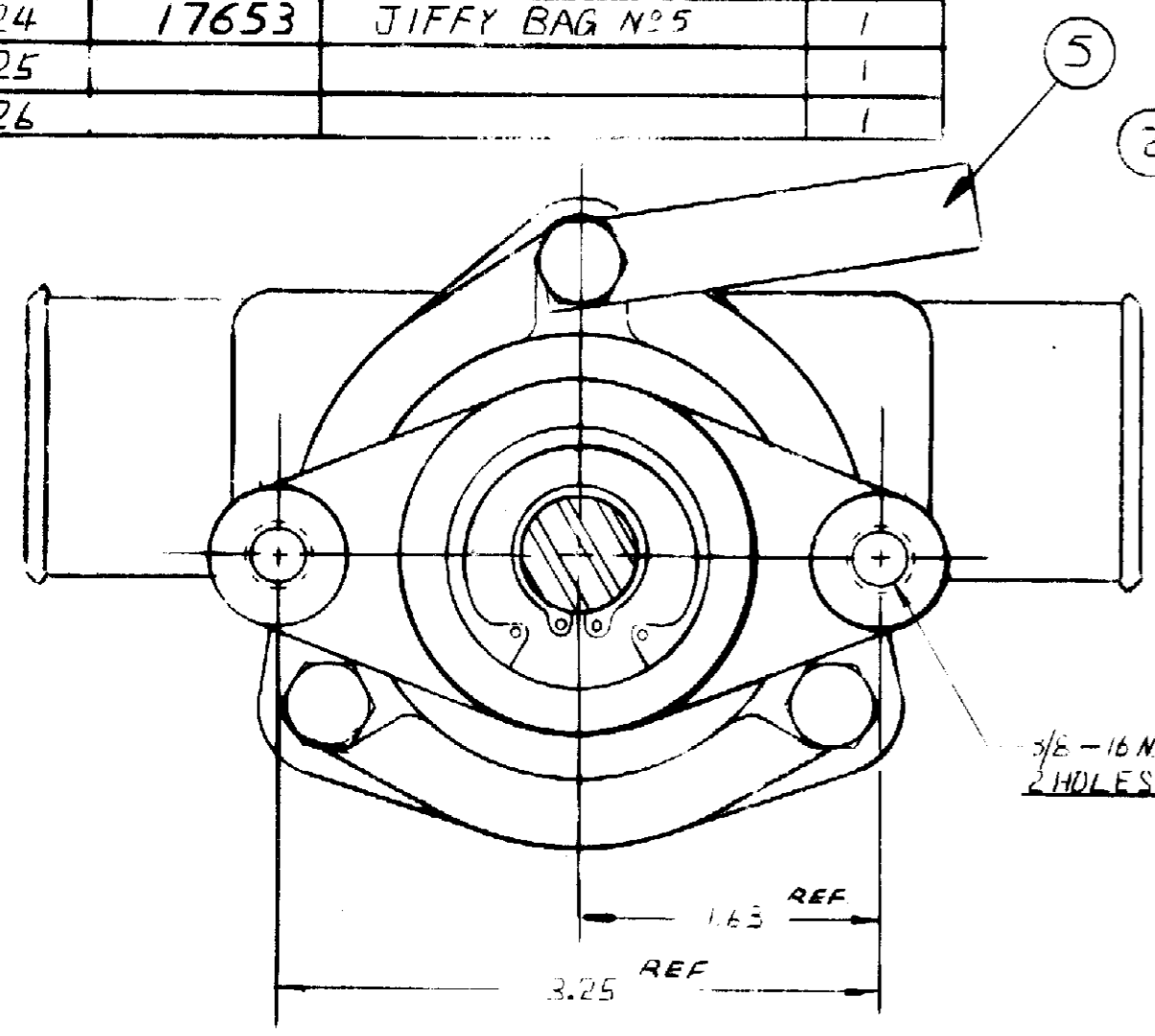
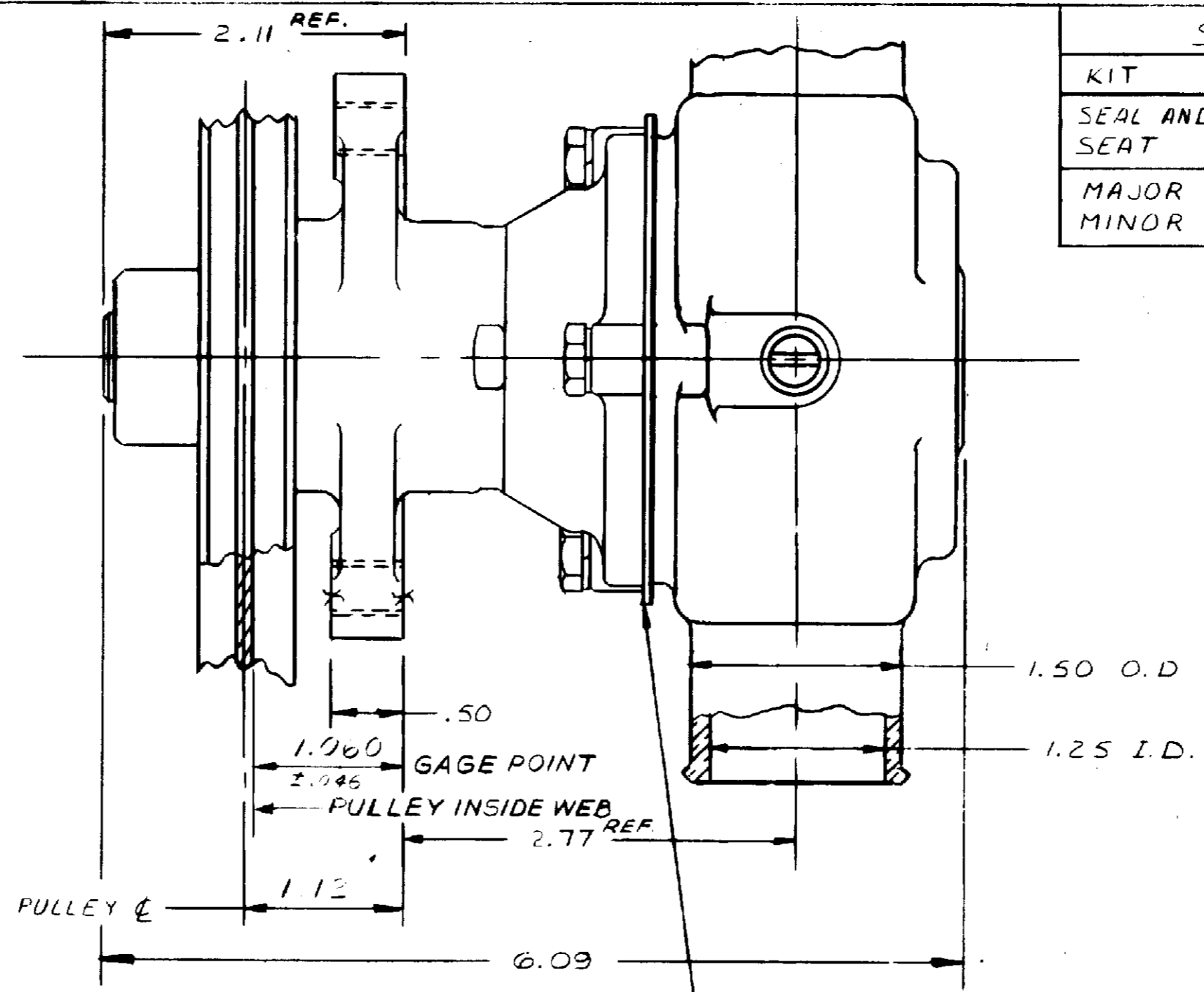

STAMP MODEL N.º; DATE CODE JN
Nº13285 TAG AND ATTACH AS SHOWN

UNLESS OTHERWISE SPECIFIED
TOLERANCE TO BE
CAST DIMENSION ± .020
MACHINED DIMENSION
FRACTIONAL ± .010
DECIMAL ± .008
ANGLES ± 1/2°
MACHINED SURFACE ROUGHNESS
ALLOW 1/16 STOCK ON ALL FINISHED
SURFACES FOR MACHINING
BREAK ALL SHARP EDGES .010 MAX.
CAST. FILLETS AND RADII 1/16 R.

SHERWOOD
A DIVISION OF HYPRO CORPORATION
4331 E. JEFFERSON AVE. - DETROIT, MICHIGAN 48217

DRAFTSMAN	DATE	CHECKER	DATE	PROJ. NO
KB	3-21-91	AVB	4/9/91	778

TITLE: RUBBER IMPELLER PUMP
MATERIAL: SEE DETAILS
DWG NO: G151

REV	DESCRIPTION	APP	DATE
A	WAS 18269 TO 18314	TLG	2-26-92

G Series Technical Guide – 15000 Impeller

Identification



GC1, GC4 & GC5



G151



G1503



G155



G157

Assembly / Disassembly Instructions

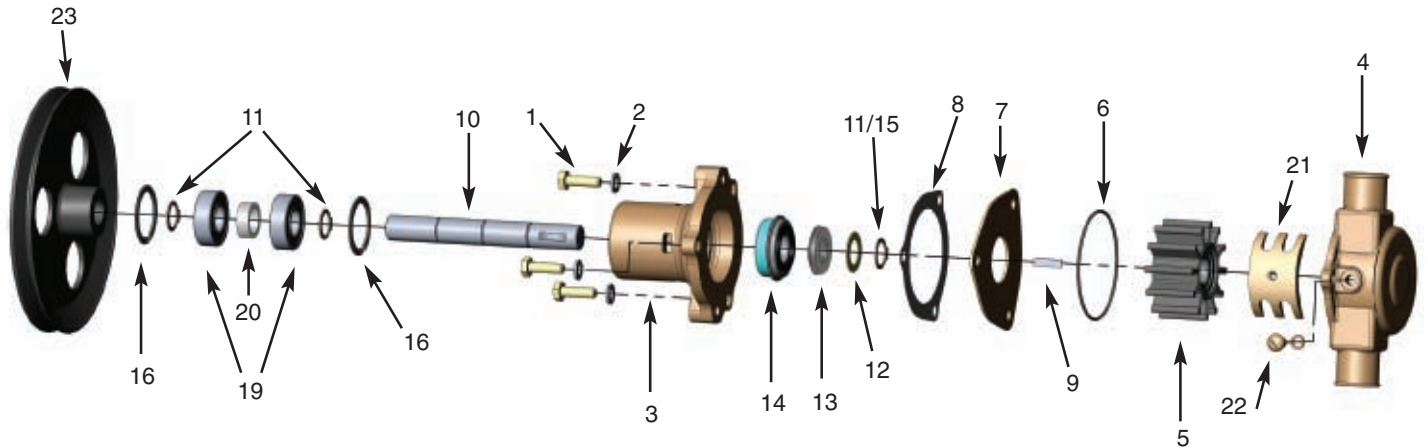

The following assembly/disassembly procedures apply to all G Series pumps. Deviations from pump to pump are primarily a result of different methods of drive and mounting.

Disassembly:

- A. Remove the screws (1) and lockwashers (2) that hold the body (3) and housing (4) together.
- B. The housing assembly including the impeller (5) can be removed from the body assembly, along with the o-ring (6), spacer plate (7) and gasket (8).
- C. Remove the woodruff key (9) from the shaft (10). If the shaft is to be used again, and if it is put in a vise, always use lead over the jaws of the vise so that the shaft is not damaged.
- D. Remove the retaining ring (11 or 15) from the shaft (impeller end). The shoulder washer (12) and seat assembly (13) can now be removed.
- E. From the drive end of the pump (pulley end, hub end, shaft end), remove retaining ring, remove pin (17), remove woodruff key (18) and loosen setscrew if used. **Note:** If the pulley (23) or hub (24) is pressed on the shaft, it will be necessary to locate a support directly between the pump body and pulley or hub as close to the shaft as possible. Press the shaft out of the pulley or hub. Make sure the body is free and not supported.
- F. For the M71, GC1, GC4 and GC5, remove the two bolts that hold the aluminum adapter onto the bearing body. Pull the adapter off of the bearing body and press the lip seal out of the adapter.
- G. Remove the large internal retaining ring (16) from the body at the end of the bearing.
- H. Support the body, and press the shaft, bearings (19), spacer (20) and retaining rings (11) out through the bearing or pulley end of the body.
- I. The seal assembly (14) is pressed into the body. It can be removed by pushing a tool through the bearing end and up against the metal or back side of the seal. **Note:** On some pumps, there is a spacer located between the pulley (hub) and bearing on the shaft. On other pumps, the bearings are positioned on the shaft with a retaining ring on each end. Support the bearings on the inner race, and push the shaft out of the bearings.

Assembly:

- A. When assembling the cam (21), put Permatex #1 on the backside of the cam and the screw (22) that retains the cam. Wipe off any Permatex that gets into the impeller cavity.
- B. Assemble a retaining ring (11) on the shaft into the second groove from the impeller end. Push the ball bearing (19) over the shaft (10). Press on the inner race of the bearing. Push the bearing up against the retaining ring. (Push the bearing on from the pulley or drive end, except for M71, GC1, GC4 and GC5 pumps). Assemble a spacer and then the second ball bearing. Assemble the second retaining ring over the shaft and up against the ball bearing, if required.
- C. There is a large internal retaining ring (16) located in the body that provides a shoulder for the bearings (approximately 1.38" from the bearing end of the body). If it has been removed, it must be inserted at this time.
- D. Press the mechanical seal (14) into the body from the impeller end. Make sure that seal is pressed in square. A tool should be used to assure proper assembly.
- E. Push the bearing and shaft assembly into the body using care not to cock the bearing. A tool is recommended that will give you uniform pressure on the bearing outer race. Lock the bearing in place with the large internal retaining ring.
- F. Assemble the seat assembly (13), shoulder washer (12) and retaining ring (11 or 15) over the shaft from the impeller end. Locate the white ceramic surface against the seal – Do not damage (scratch) the white ceramic surface of the seat, or the seal and seat assembly might leak. Lubricate the rubber part of the seat and use a tool for ease of assembly.
- G. For the M71, GC1, GC4 and GC5, press a new lip seal into the aluminum adapter (with the metal backing ring away from the engine). Replace the adapter onto the bearing body. Assemble the lockwashers and bolts to the adapter. Torque with bolts to 24 ft. lbs.

Assembly / Disassembly Instructions (continued)

- H. While supporting the shaft, press the pulley/gear (23) or hub (24) onto the shaft. Secure pulley/hub with pin (17) or key (18) and retaining ring or setscrew as needed.
- I. Press the woodruff key (9) into the shaft. Make sure the stainless steel key is used at this location.
- J. Assemble the impeller (5) into the housing (4). **Note:** Do not use petroleum-based fluid to lubricate the impeller.
- K. Place the o-ring (6) in the groove in the housing (4). A small dab of grease will help hold it in position until the housing to body screws are tightened. Assemble the gasket (8) and spacer plate (7) on the body (3), and line up the screw holes.
- L. Replace the lockwashers (20) and tighten the screws (1). Torque the screws to 84 in.-lbs.
- M. After installation, inspect the pump seal, lip seal, body, housing and cam areas for leaks.

Sherwood #		GC1	GC4	GC5	G151	G155	G157	G1503
Item	QTY							
1	Screw	3	12857	12857	12857	12857	12857	12857
2	Lockwasher	3	12710	12710	12710	12710	12710	12710
3	Body	1	14160	14160	19907	12227	12227	23231
4	Housing	1	17684	17684	17684	17684	19880	17684
5	Impeller	1	15000	15000	15000	15000	15000	15000
6	O-ring	1	12231	12231	12231	12231	12231	12231
7	End Plate	1	12856	12856	12856	12856	12856	22836
8	Gasket	1	12855	12855	12855	12855	12855	
9	Key	1	4432	4432	4432	4432	4432	4432
10	Shaft	1	21069	21069	19843	19570	19570	21231
11	Retaining Ring (Ext)	2/3	4258	4258	4258	4258	4258	4258
12	Washer	1	4264	4264	4264	4264	4264	4264
15	Retaining Ring (Ext)	1	14161	14161				
16	Retaining Ring (Int)	2	4259	4259	4259	4259	4259	4259
19	Ball Bearing	2	23448	23448	23448	23448	23448	23448
20	Spacer	1	5133	5133	19906	5133	5133	23229
21	Cam	1	18398	18398	18398	18314	18314	18314
22	Cam Screw	1	10515	10515	10515	10515	10515	
23	Drive Pulley or Gear	1	14184	14184	14184	15055	15055	23870
24	Hub	1					21232	
13/14	Water Seal/Seat Assy	1	12859	12859	12859	12859	12859	12859/12966
	Oil Seal	1	10514	10514	10514			12966
	Cover							21173
	Minor Repair Kit		23980	23980	23980	23980	23980	23980
	Major Repair Kit		23981	23981	23981	23981	23981	23256

Inspection

The #1 reason for premature engine wear is overheating.

To maintain engine performance, insist upon genuine Sherwood impellers and service kits.

Recommended inspection to be performed at any service interval:

- ImpellerInspect for cracks or tears. Also, inspect for excessive abrasion of vane ends. Replace annually, or if any of the conditions exist, as in the picture. (See maintenance schedule on back page.)
- Wear PlateInspect for wear, flatness, and pin for fatigue. Replace at major pump rebuild or if wear is evident to maintain pump flow and suction performance.
- CamReplace at minor or major pump rebuild or if pitting/wear is evident.
- CoverReplace at major pump rebuild or if wear exists to maintain pump flow and suction performance.
- Mechanical SealReplace at minor and major pump rebuild or if leaking.
- Lip SealReplace at major pump rebuild or if leaking.
- ShaftInspect for wear in area of lip seal and rubber impeller. Grooving of lip seal area or heavy fretting of the impeller end shaft will require shaft replacement.
- BearingInspect for loss of grease, corrosion or rough rotation. Replace at major pump rebuild.

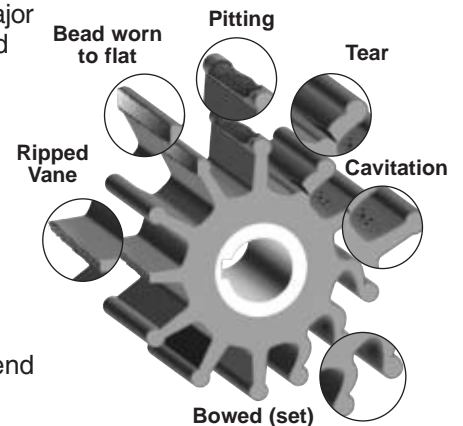

Preventative Maintenance

Maintenance Schedule	Pleasure Boating (Low Hours)		Commercial/Fishing Use (High Hours)	
	Light Duty	Severe Duty (High RPM, Silt or Sand)	Heavy Duty	Severe Duty (High RPM, Silt or Sand)
Impeller Kit	Every year	6 months	6 months	3 months
Minor Kit	2 years	Every year	Every year	6 months
Major Kit	4 years	2 years	2 years	Every year

	Impeller Kit 15000K	Minor Kit 23980	Major Kit 23981
	1-15000 Impeller 1-12231 O-Ring 1-12855 Gasket	1-15000 Impeller 1-12231 O-Ring 1-12855 Gasket 1-12859 Seal 1-04258 Snap Ring 1-04432 Key 1-04264 Washer 2-04259 Snap Rings	1-15000 Impeller 1-12231 O-Ring 1-12855 Gasket 1-12859 Seal 3-04258 Snap Ring 1-04432 Key 1-04264 Washer 2-04259 Snap Rings 2-23448 Bearings 1-12856 End Plate 1-18398 Cam 1-10515 Cam Screw
GC1	X	X	X
GC4	X	X	X
GC5	X	X	X
G151	X	X	X
G155	X	X	X
G157	X	X	X
G1503	X	X	

Note: When using the Minor Kit 23980 or Major Kit 23981 for the GC1, GC4 and GC5, also replace the 10514 Lip Seal, which is not included in these kits. When using Minor Kit 23980 for the G1503, also replace the oil seal 12966.



HYPRO

**Pentair Water
MARINE PRODUCTS GROUP**

375 Fifth Avenue NW • New Brighton, MN 55112
Phone: (651) 766-6300 • 800-471-0460 • Fax: 800-672-7023
www.sherwoodpumps.com