

ITEM NO.	PART NUMBER	DESCRIPTION	QTY.
1	12596	SHAFT	1
2	12211	BALL BEARING	2
3	05133	SPACER	1
4	04258	EXT. RETAINING RING	3
5	04259	INT. RETAINING RING	2
6	04264	FLAT WASHER	1
7	12314	TYPE 6A SEAL/SEAT ASSY	1
8	12328	BODY - MACHINED	1
9	12855	GASKET	1
10	12856	WEAR PLATE	1
11	12907	HOUSING - MACH	1
12	12231	O-RING	1
13	04432	WOODRUFF KEY	1
14	19995	SCREW 1/4-20 ROUND HD	1
15	19996	CAM WASHER	1
16	10944	CAM	1
17	10615	RUBBER IMPELLER	1
18	12926	HUB	1
19	12927	SLEEVE - SHAFT	1
20	09420	TAPER GROOVE PIN	1
21	12857	1/4-20 HHCS	3
22	12710	LOCKWASHER	3
23	13285	TAG	1
24	23083	LABEL	1

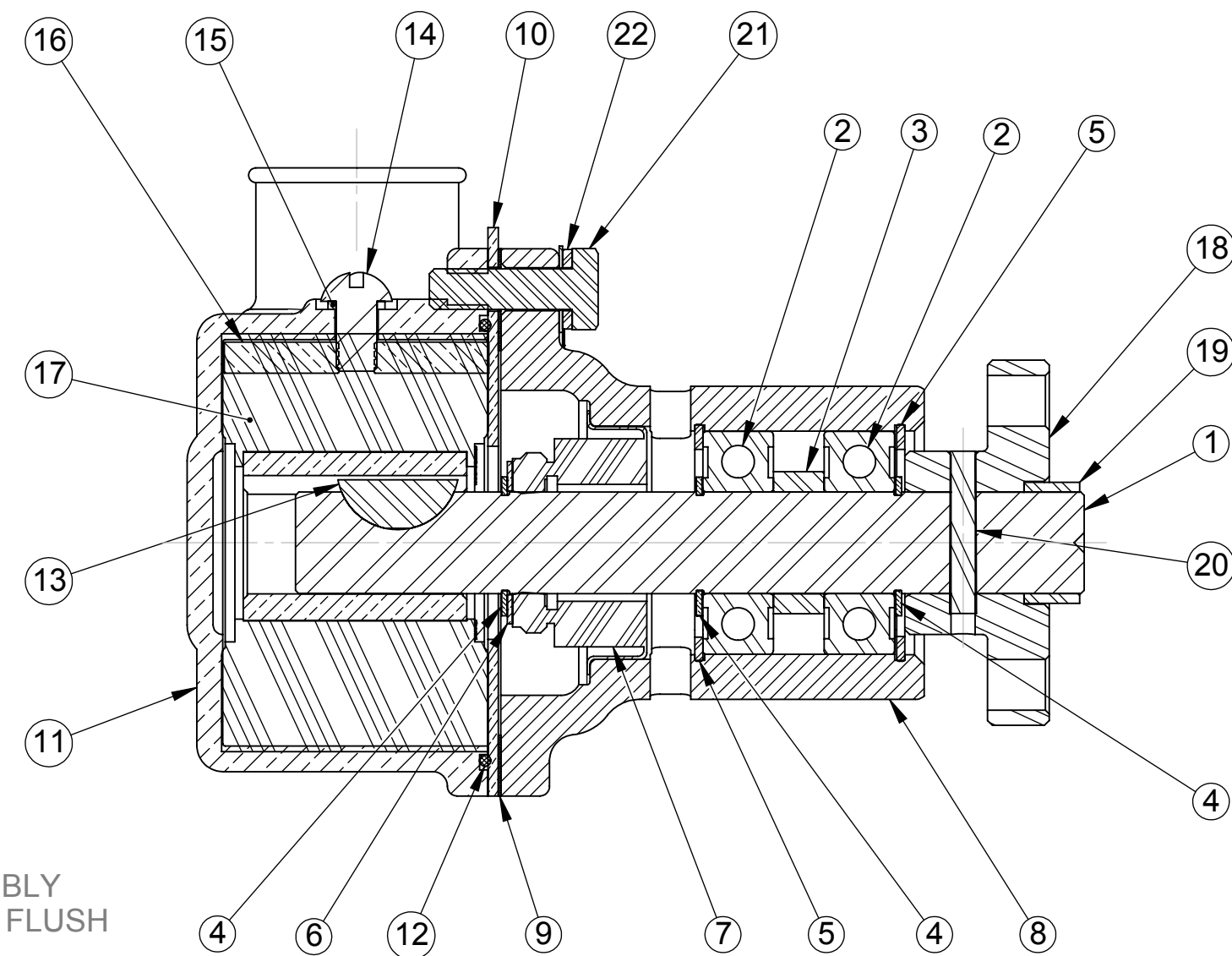
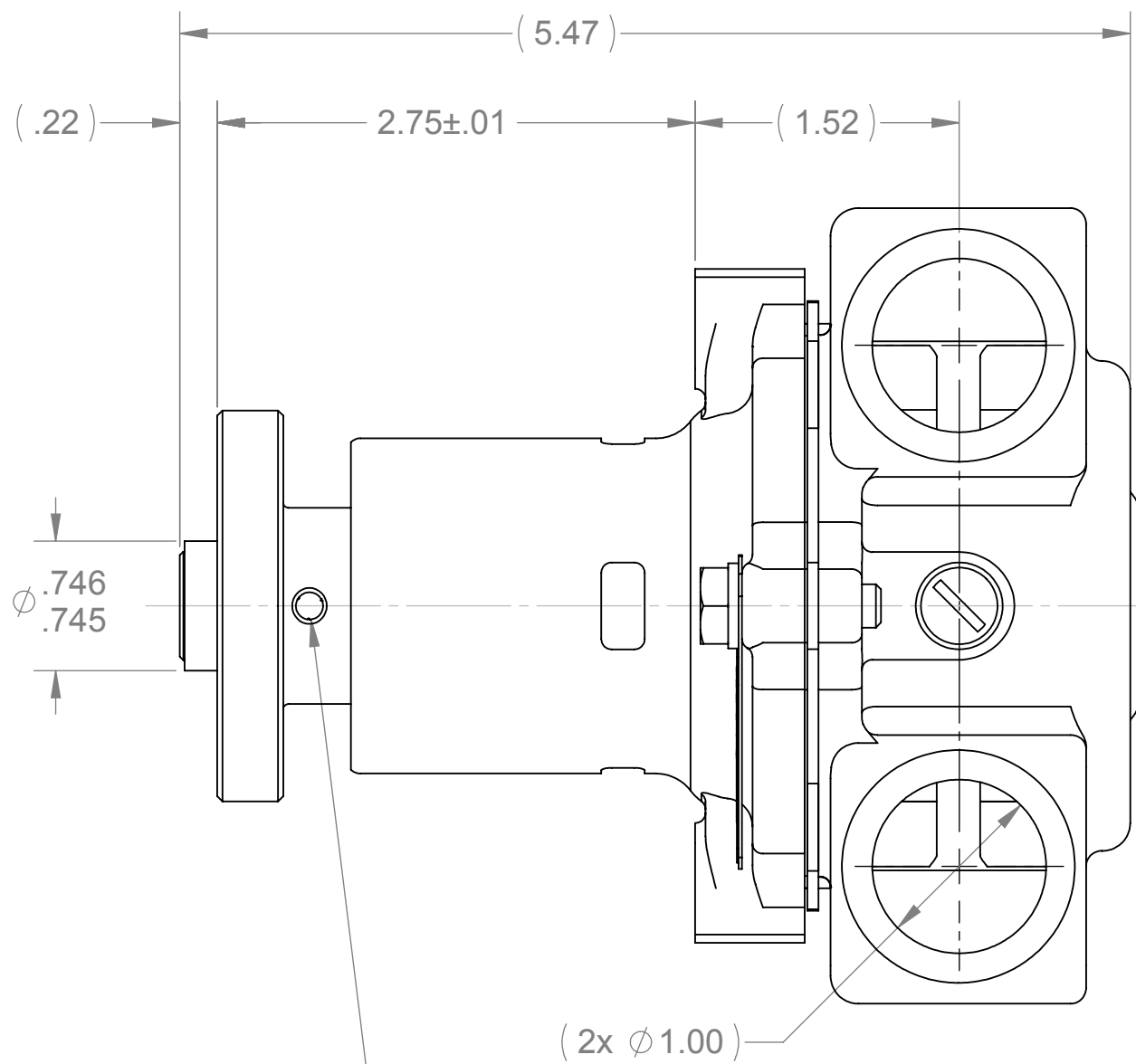

SECTION A-A

Ø 5/32" DRILL THRU TO OTHER SIDE AT ASSEMBLY
DEBURR. PRESS TAPER GROOVE PIN, ITEM 19, FLUSH

NOTES:

1. APPLY BEAD OF PERMATEX AROUND THREADED HOLE IN CAM PRIOR TO ASSEMBLY, (ITEM 16).
2. USE WATER ONLY WHEN INSTALLING TYPE 6A SEAL/SEAT ASSY, (ITEM 7).
3. USE COOLANT TO AID IN INSTALLATION OF RUBBER IMPELLER, (ITEM 17).
4. TORQUE 1/4-20 HHCS TO 5 - 8 FT/LBS, (ITEM 21).
5. PRESSURE TEST PUMP TO 20 - 30 PSI.
6. PRINT "G55" AND "DATE CODE" ON LABEL, (ITEM 24).

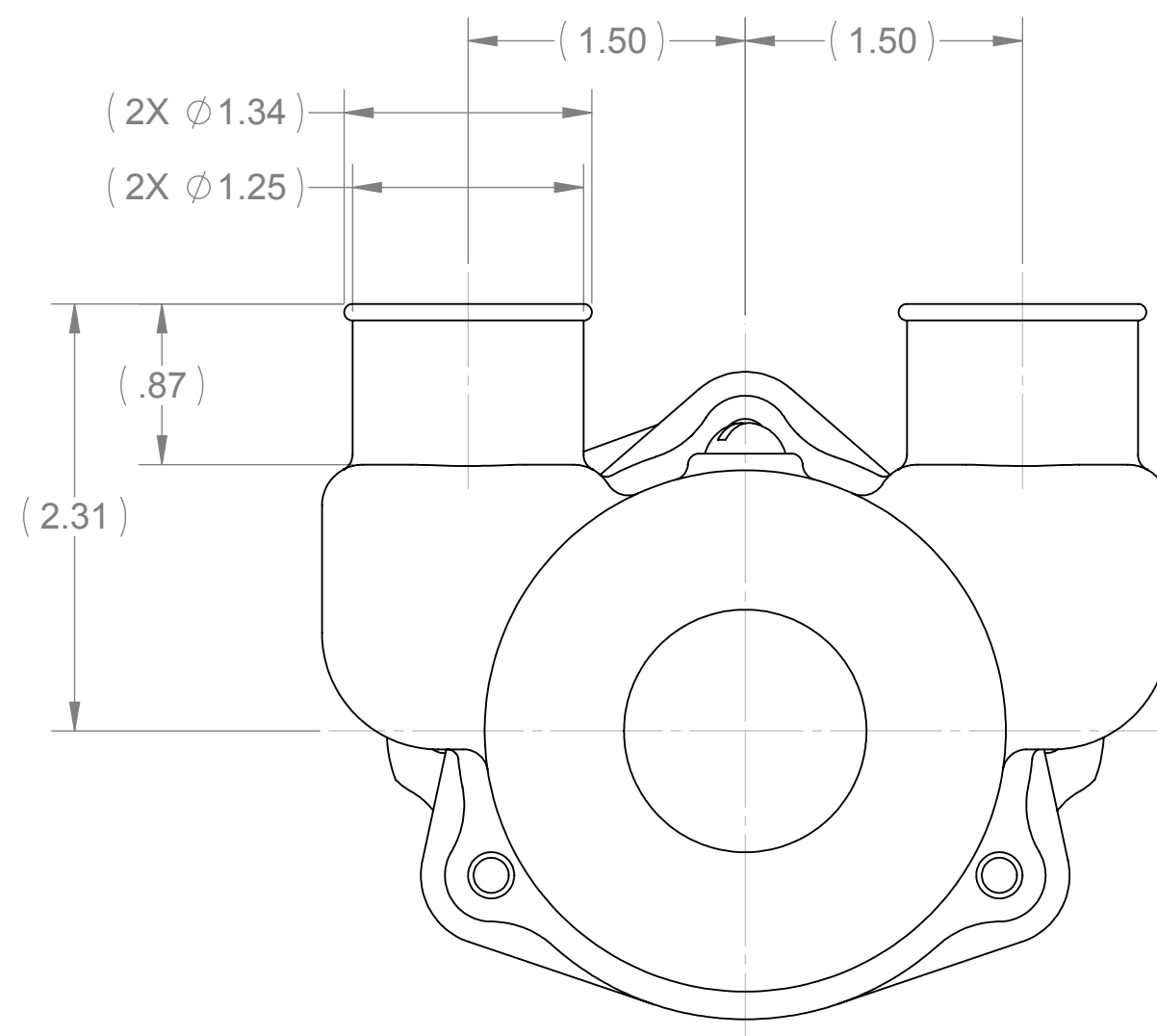
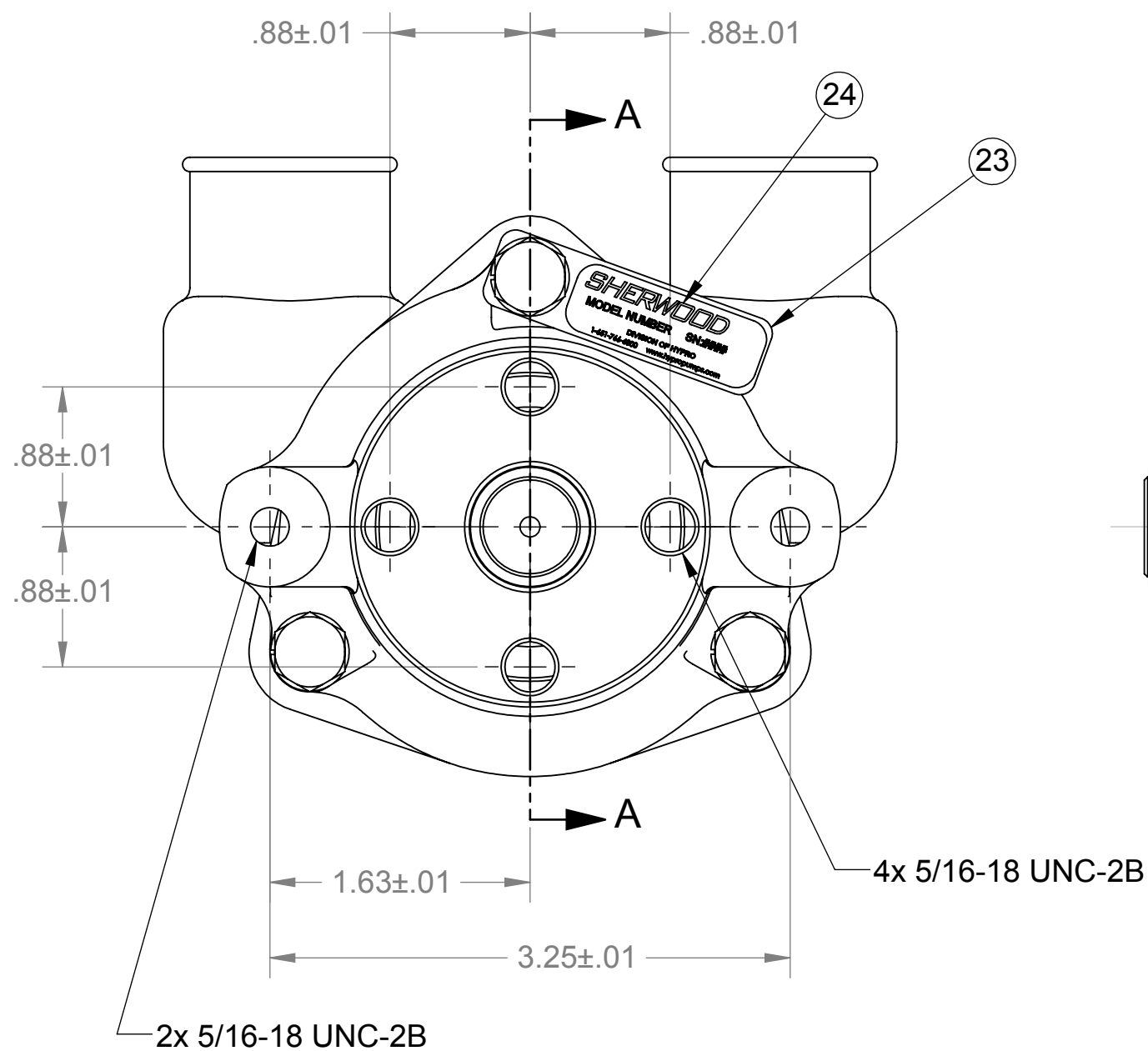

REV.	ECN.	DESCRIPTION	CHKD.	DATE
M	6830	CHANGED 12926 FROM SQUARE TO ROUND, UPDATED DRAWING	PEB	5/9/2008
L	6527	REMOVED 12256 SEAT ASSY. & 10515C CAM SCREW ASSY. ADDED 19995 CAM SCREW & 19996 CAM WASHER. NOTE 2 WAS "USE PAC-EASE OR EQUIV". REDIMENSIONED	PEB	11/15/2007
K	6195	ADDED NOTES, REDRAWN ON NEW FORMAT	PB	6/15/2007

SHERWOOD
A Div. of Hypro Corporation A PENTAIR COMPANY
375 Fifth Avenue NW, New Brighton, MN 55112, (651) 766-6300

DRAWING BASED ON ASME Y14.5M-1994 DO NOT SCALE PRINT

THIRD ANGLE PROJECTION

SCALE 1:1 SHEET NUMBER 1 OF 1

PART DESCRIPTION **RUBBER IMPELLER PUMP**

REPLACES PART NO. _____ REV. _____

DWG BY: BK DATE: 1/6/1978

CHECKED BY: AVB DATE: 3/14/1989

APPROVED BY: _____ DATE: _____

THIS DRAWING IS THE PROPERTY OF HYPRO, AND WITHOUT WRITTEN AUTHORIZATION, MUST NOT BE COPIED OR COMMUNICATED

PART NUMBER **G55-2** REV. **M**

G Series Technical Guide – 10615 Impeller

Identification



G5, G7, G7B & G50



G45-1



G45-2 & G46



M70 & M71



L10B



K90

Assembly / Disassembly Instructions

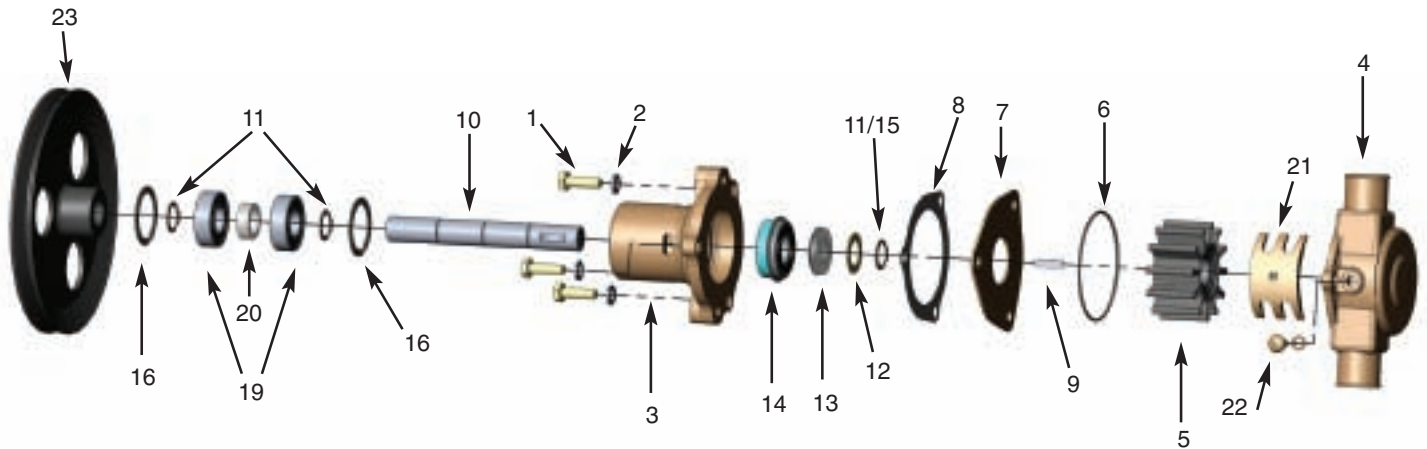

The following assembly/disassembly procedures apply to all G Series pumps. Deviations from pump to pump are primarily a result of different methods of drive and mounting.

Disassembly:

- A. Remove the screws (1) and lockwashers (2) that hold the body (3) and housing (4) together.
- B. The housing assembly including the impeller (5) can be removed from the body assembly, along with the o-ring (6), spacer plate (7) and gasket (8).
- C. Remove the woodruff key (9) from the shaft (10). If the shaft is to be used again, and if it is put in a vise, always use lead over the jaws of the vise so that the shaft is not damaged.
- D. Remove the retaining ring (11 or 15) from the shaft (impeller end). The shoulder washer (12) and seat assembly (13) can now be removed.
- E. From the drive end of the pump (pulley end, hub end, shaft end), remove retaining ring, remove pin (17), remove woodruff key (18) and loosen setscrew if used. **Note:** If the pulley (23) or hub (24) is pressed on the shaft, it will be necessary to locate a support directly between the pump body and pulley or hub as close to the shaft as possible. Press the shaft out of the pulley or hub. Make sure the body is free and not supported.
- F. For the M71, GC1, GC4 and GC5, remove the two bolts that hold the aluminum adapter onto the bearing body. Pull the adapter off of the bearing body and press the lip seal out of the adapter.
- G. Remove the large internal retaining ring (16) from the body at the end of the bearing.
- H. Support the body, and press the shaft, bearings (19), spacer (20) and retaining rings (11) out through the bearing or pulley end of the body.
- I. The seal assembly (14) is pressed into the body. It can be removed by pushing a tool through the bearing end and up against the metal or back side of the seal. **Note:** On some pumps, there is a spacer located between the pulley (hub) and bearing on the shaft. On other pumps, the bearings are positioned on the shaft with a retaining ring on each end. Support the bearings on the inner race, and push the shaft out of the bearings.

Assembly:

- A. When assembling the cam (21), put Permatex #1 on the backside of the cam and the screw (22) that retains the cam. Wipe off any Permatex that gets into the impeller cavity.
- B. Assemble a retaining ring (11) on the shaft into the second groove from the impeller end. Push the ball bearing (19) over the shaft (10). Press on the inner race of the bearing. Push the bearing up against the retaining ring. (Push the bearing on from the pulley or drive end, except for M71, GC1, GC4 and GC5 pumps). Assemble a spacer and then the second ball bearing. Assemble the second retaining ring over the shaft and up against the ball bearing, if required.
- C. There is a large internal retaining ring (16) located in the body that provides a shoulder for the bearings (approximately 1.38" from the bearing end of the body). If it has been removed, it must be inserted at this time.
- D. Press the mechanical seal (14) into the body from the impeller end. Make sure that seal is pressed in square. A tool should be used to assure proper assembly.
- E. Push the bearing and shaft assembly into the body using care not to cock the bearing. A tool is recommended that will give you uniform pressure on the bearing outer race. Lock the bearing in place with the large internal retaining ring.
- F. Assemble the seat assembly (13), shoulder washer (12) and retaining ring (11 or 15) over the shaft from the impeller end. Locate the white ceramic surface against the seal – Do not damage (scratch) the white ceramic surface of the seat, or the seal and seat assembly might leak. Lubricate the rubber part of the seat and use a tool for ease of assembly.
- G. For the M71, GC1, GC4 and GC5, press a new lip seal into the aluminum adapter (with the metal backing ring away from the engine). Replace the adapter onto the bearing body. Assemble the lockwashers and bolts to the adapter. Torque with bolts to 24 ft. lbs.

Assembly / Disassembly Instructions (continued)

- H. While supporting the shaft, press the pulley/gear (23) or hub (24) onto the shaft. Secure pulley/hub with pin (17) or key (18) and retaining ring or setscrew as needed.
- I. Press the woodruff key (9) into the shaft. Make sure the stainless steel key is used at this location.
- J. Assemble the impeller (5) into the housing (4). **Note:** Do not use petroleum-based fluid to lubricate the impeller.
- K. Place the o-ring (6) in the groove in the housing (4). A small dab of grease will help hold it in position until the housing to body screws are tightened. Assemble the gasket (8) and spacer plate (7) on the body (3), and line up the screw holes.
- L. Replace the lockwashers (20) and tighten the screws (1). Torque the screws to 84 in.-lbs.
- M. After installation, inspect the pump seal, lip seal, body, housing and cam areas for leaks.

Sherwood #		G5	G7	G7B	G45-1	G46	G50	G55-2	K90	L10B	M71
Engine Manufacturer		Chrys.	Chrys.	Chrys.	Chris Craft	OMC	Chrys.		Isuzu		
Engine Model		318, 340	318, 360	318, 360	454	V8 Chevy	318, 340		4,6 Cyl Diesel		
ITEM	QTY	3675763	4142878	4142878	16.80-18347	985096	3619212		X-26-230-1023		
1	Screw	3	12857	12857	12857	12857	12857	12857	12857	12857	12857
2	Lockwasher	3	12710	12710	12710	12710	12710	12710	12710	12710	12710
3	Body	1	12227	12227	19789	12328	12328	12227	12328	12227	19948
4	Housing	1	12228	12952	12952	12228	12952	12228	12907	12228	13899
5	Impeller	1	10615	10615	10615	10615	10615	10615	10615	10615	10615
6	O-ring	1	12231	12231	12231	12231	12231	12231	12231	12231	12231
7	End Plate	1	12856	12856	12856	12856	12856	12856	12856	12856	12856
8	Gasket	1	12855	12855	12855	12855	12855	12855	12855	12855	12855
9	Key	1	4432	4432	4432	4432	4432	4432	4432	4432	4432
10	Shaft	1	12233	13363	13363	12612	13363	12233	12596	12596	13363
11	Retaining Ring (Ext)	2/3	4258	4258	4258	4258	4258	4258	4258	4258	4258
12	Washer	1	4264	4264	4264	4264	4264	4264	4264	4264	4264
15	Retaining Ring (Ext)	1	12305				12305				
16	Retaining Ring (Int)	2	4259	4259	4259	4259	4259	4259	4259	4259	4259
17	Pin	1	11541			12791		11541	9420		
18	Key	1	12622				12622				
19	Ball Bearing	2	23448	23448	23448	23448	23448	23448	23448	23448	23448
20	Spacer	1	5133	5133	5133	5133	5133	5133	5133	5133	5133
21	Cam	1	10944	10929	10929	10944	10929	10944	10944	10944	10944
22	Cam Screw	1	10515	10515	10515	10515	10515	10515	10515	10515	10515
23	Drive Pulley or Gear	1	12326	15055	15055		15048	12323		14992	
24	Hub	1				12615			12926		13795
13/14	Water Seal/Seat Assy	1	12859	12859	12859	12859	12859	12859	12859	12859	12859
	Oil Seal	1									10514
	Minor Repair Kit		23976	23976	23976	23976	23976	23976	23976	23976	23976
	Major Repair Kit		23977	23977	23977	23977	23977	23977	23977	23977	23977

Inspection

The #1 reason for premature engine wear is overheating.

To maintain engine performance, insist upon genuine Sherwood impellers and service kits.

Recommended inspection to be performed at any service interval:

- Impeller Inspect for cracks or tears. Also, inspect for excessive abrasion of vane ends. Replace annually, or if any of the conditions exist, as in the picture. (See maintenance schedule on back page.)
- Wear Plate Inspect for wear, flatness, and pin for fatigue. Replace at major pump rebuild or if wear is evident to maintain pump flow and suction performance.
- Cam Replace at minor or major pump rebuild or if pitting/wear is evident.
- Cover Replace at major pump rebuild or if wear exists to maintain pump flow and suction performance.
- Mechanical Seal Replace at minor and major pump rebuild or if leaking.
- Lip Seal Replace at major pump rebuild or if leaking.
- Shaft Inspect for wear in area of lip seal and rubber impeller. Grooving of lip seal area or heavy fretting of the impeller end shaft will require shaft replacement.
- Bearing Inspect for loss of grease, corrosion or rough rotation. Replace at major pump rebuild.

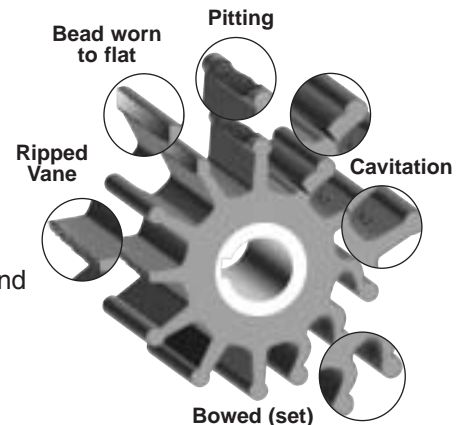

Preventative Maintenance

Maintenance Schedule	Pleasure Boating (Low Hours)		Commercial/Fishing Use (High Hours)	
	Light Duty	Severe Duty <small>(High RPM, Silt or Sand)</small>	Heavy Duty	Severe Duty <small>(High RPM, Silt or Sand)</small>
Impeller Kit	Every year	6 months	6 months	3 months
Minor Kit	2 years	Every year	Every year	6 months
Major Kit	4 years	2 years	2 years	Every year

	Impeller Kit 10615K	Minor Kit 23976	Major Kit 23977
	1-10615 Impeller 1-12231 O-Ring 1-12855 Gasket	1-10615 Impeller 1-12231 O-Ring 1-12855 Gasket 1-12859 Seal 1-04258 Snap Ring 1-04432 Key 1-04264 Washer 2-04259 Snap Rings	1-10615 Impeller 1-12231 O-Ring 1-12855 Gasket 1-12859 Seal 3-04258 Snap Ring 1-04432 Key 1-04264 Washer 2-04259 Snap Rings 2-23448 Bearings 1-12856 End Plate 1-10929 Cam 1-10515 Cam Screw
G5	X	X	X
G7	X	X	X
G7B	X	X	X
G45-1	X	X	X
G46	X	X	X
G50	X	X	X
G55-2	X	X	X
K90	X	X	X
L10B	X	X	X
M71*	X	X	X

** Note: When using the Minor Kit 23976 or Major Kit 23977 for the M71, also replace the 10514 Lip Seal, which is not included in these kits.*



**Pentair Water
MARINE PRODUCTS GROUP**

375 Fifth Avenue NW • New Brighton, MN 55112
Phone: (651) 766-6300 • 800-471-0460 • Fax: 800-672-7023
www.sherwoodpumps.com

