

ITEM NO.	PART NUMBER	DESCRIPTION	QTY.
1	12441	SHAFT, RUBBER IMP.	1
2	12442	COUPLING - DRIVE SHAFT	1
3	12211	BALL BEARING	2
4	12440	BODY - MACHINED	1
5	10514C	LIP SEAL	1
6	04432	WOODRUFF KEY	1
7	10072	CAM	1
8	09959	RUBBER IMPELLER	1
9	19995	SCREW 1/4-20 ROUND HD	1
10	19996	CAM WASHER	1
11	11360	GASKET - FIBER	1
12	11389	PUMP COVER	1
13	11417	FLAT HD MACH SCREW	4

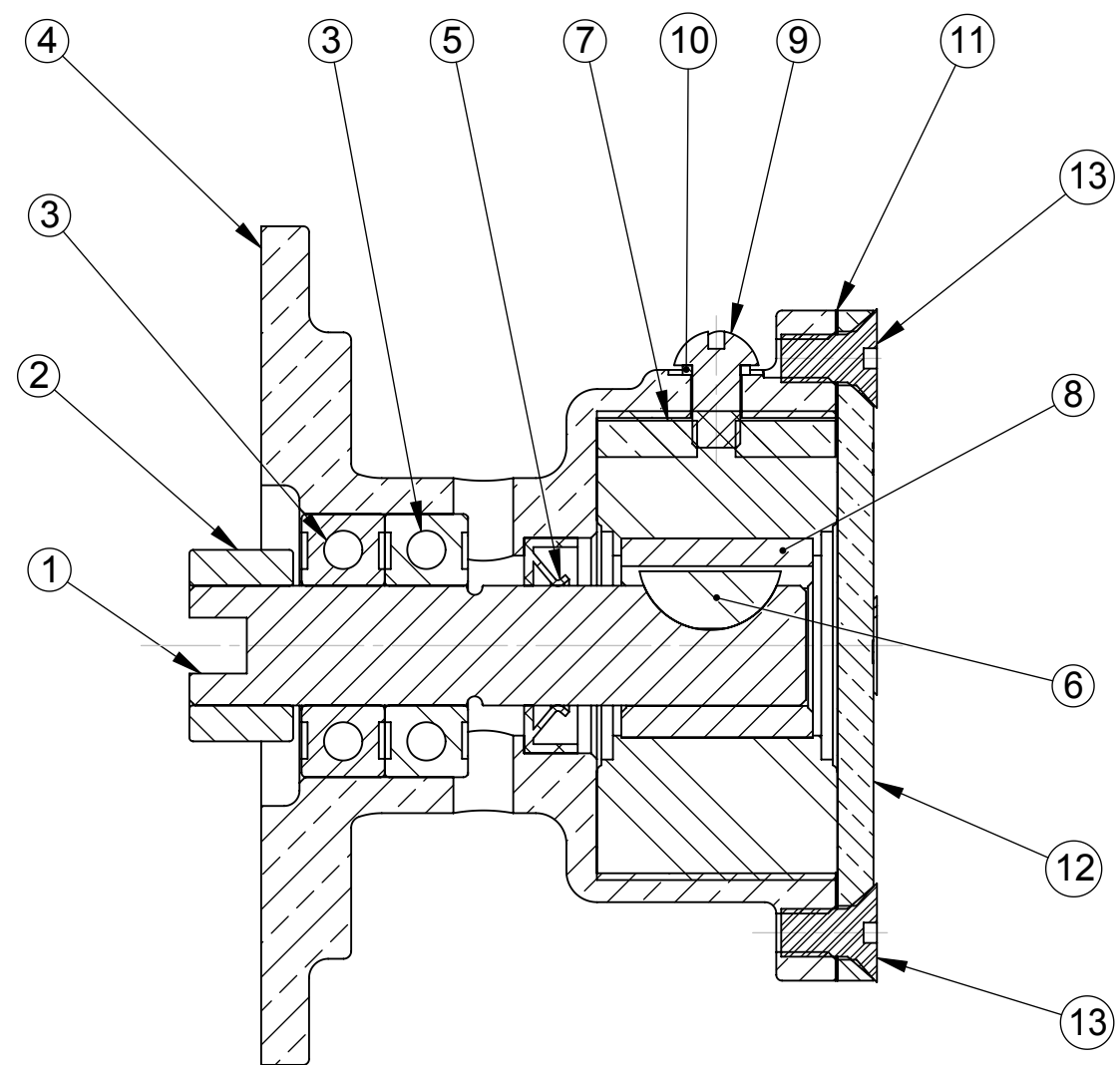

SECTION A-A

NOTES:

- ① 1. APPLY BEAD OF PERMATEX TO O.D. OF LIP SEAL, — LIP SEAL, ITEM 3.
- 2. APPLY SIL-GLYDE TO SEAL LIP I.D. PRIOR TO SHAFT INSTALLATION, ITEM 5
- 3. APPLY BEAD OF PERMATEX AROUND THREADED HOLE IN CAM PRIOR TO ASSEMBLY, ITEM 7.
- 4. USE COOLANT TO AID IN INSTALLATION OF RUBBER IMPELLER, ITEM 8.
- 5. TEST PUMP WITH VALVE OPEN FOR ONE MINUTE, THEN PRESSURIZE PUMP TO 20 - 30 PSI, TO CHECK LIP SEAL FOR LEAKS.
- 6. STAMP "G65" AND "DATE CODE" ON COVER, ITEM 8.

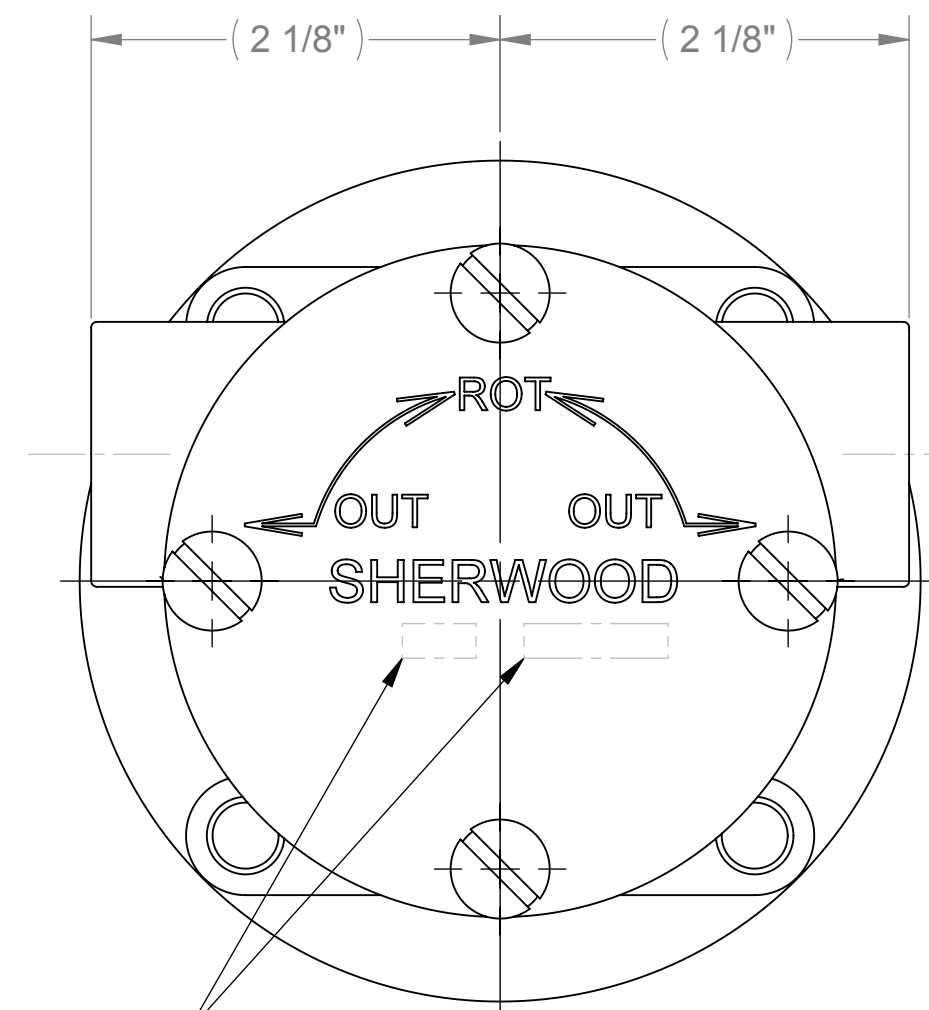
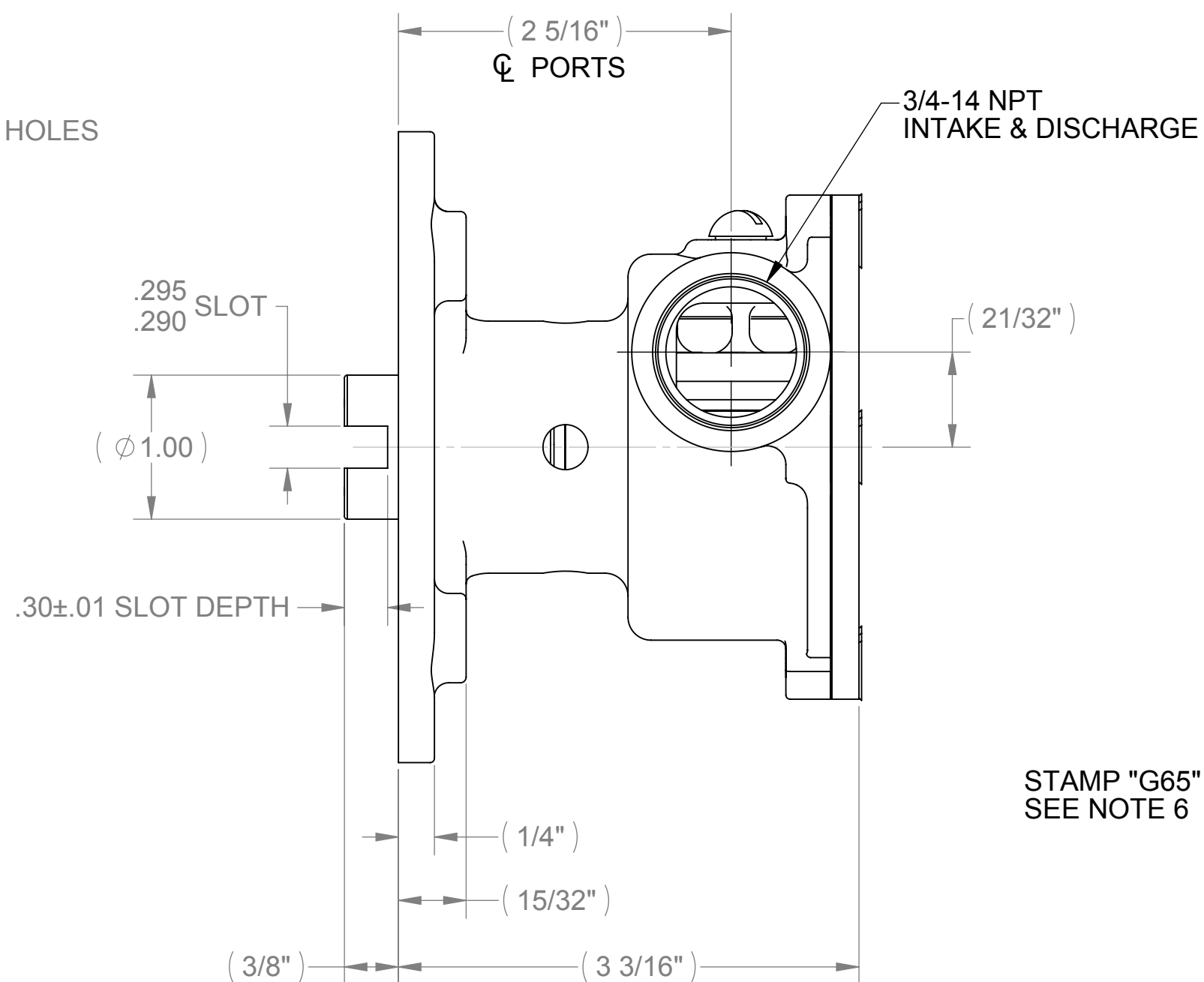
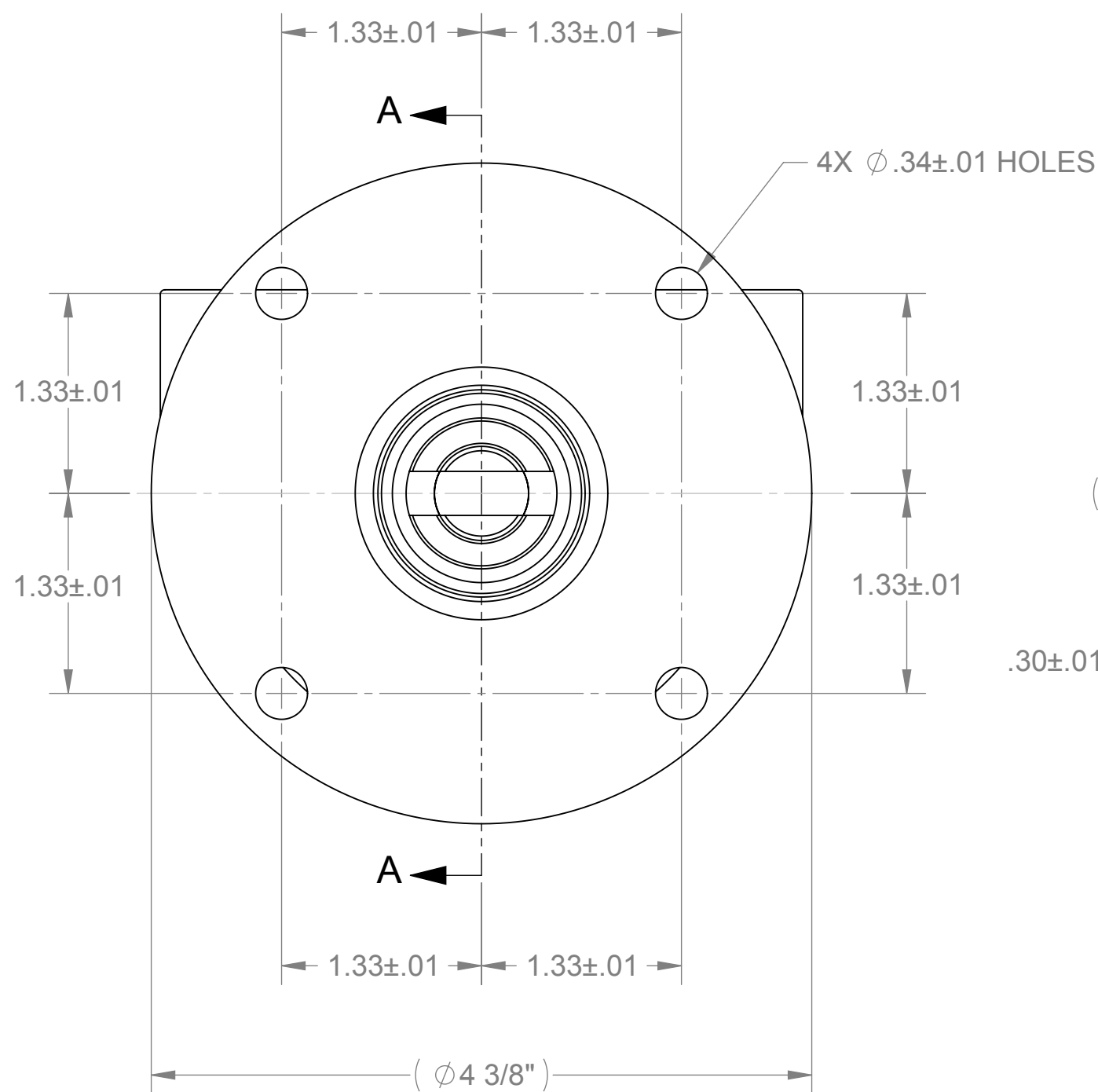

STAMP "G65" & "DATE CODE" SEE NOTE 6

SHERWOOD A Div. of Hypro Corporation A PENTAIR COMPANY 375 Fifth Avenue NW, New Brighton, MN 55112, (651) 766-6300		REPLACES PART NO.	REV.
DRAWING BASED ON ASME Y14.5M-1994 DO NOT SCALE PRINT		DWG BY: RI	DATE: 12/22/1980
THIRD ANGLE PROJECTION		CHECKED BY: RBM	DATE: 12/23/1980
SCALE: 1:1	SHEET NUMBER: 1 OF 1	APPROVED BY:	DATE:
PART DESCRIPTION: PUMP ASSY - RUBBER IMP.		THIS DRAWING IS THE PROPERTY OF HYPRO, AND WITHOUT WRITTEN AUTHORIZATION, MUST NOT BE COPIED OR COMMUNICATED	
		PART NUMBER: G65	REV.: R

REV.	ECN.	DESCRIPTION	CHKD.	DATE
R	6675	REMOVED NOTE 1, REDIMENSIONED	PEB	2/12/2008
P	6386	ADD NOTES, REDRAWN ON NEW FORMAT	PEB	8/7/2007