

ITEM NO.	PART NUMBER	DESCRIPTION	QTY.
1	13272	SHAFT	1
2	13270	HEX NUT - 1/2-20 UNF	1
3	13271	KEY - #405	1
4	04257	BALL BEARING	2
5	06602	O-RING 2-114	1
6	10514C	SEAL, SINGLE LIP	1
7	19995	SCREW 1/4-20 ROUND HD	1
8	19996	CAM WASHER	1
9	12231	O-RING	1
10	11797	1/4-20 FLAT HEAD MACHINE SCR	4
11	15883	CAM	1
12	11795	COVER	1
13	04432	NON-ROCKING WOODRUFF KEY	1
14	09959	RUBBER IMPELLER	1
15	12582	RETAIN RING - EXT	1
16	11794	BODY - RUBBER IMPELLER	1
17	04259	INT. RETAINING RING -137	1
18	13273	WASHER - MACHINED	1

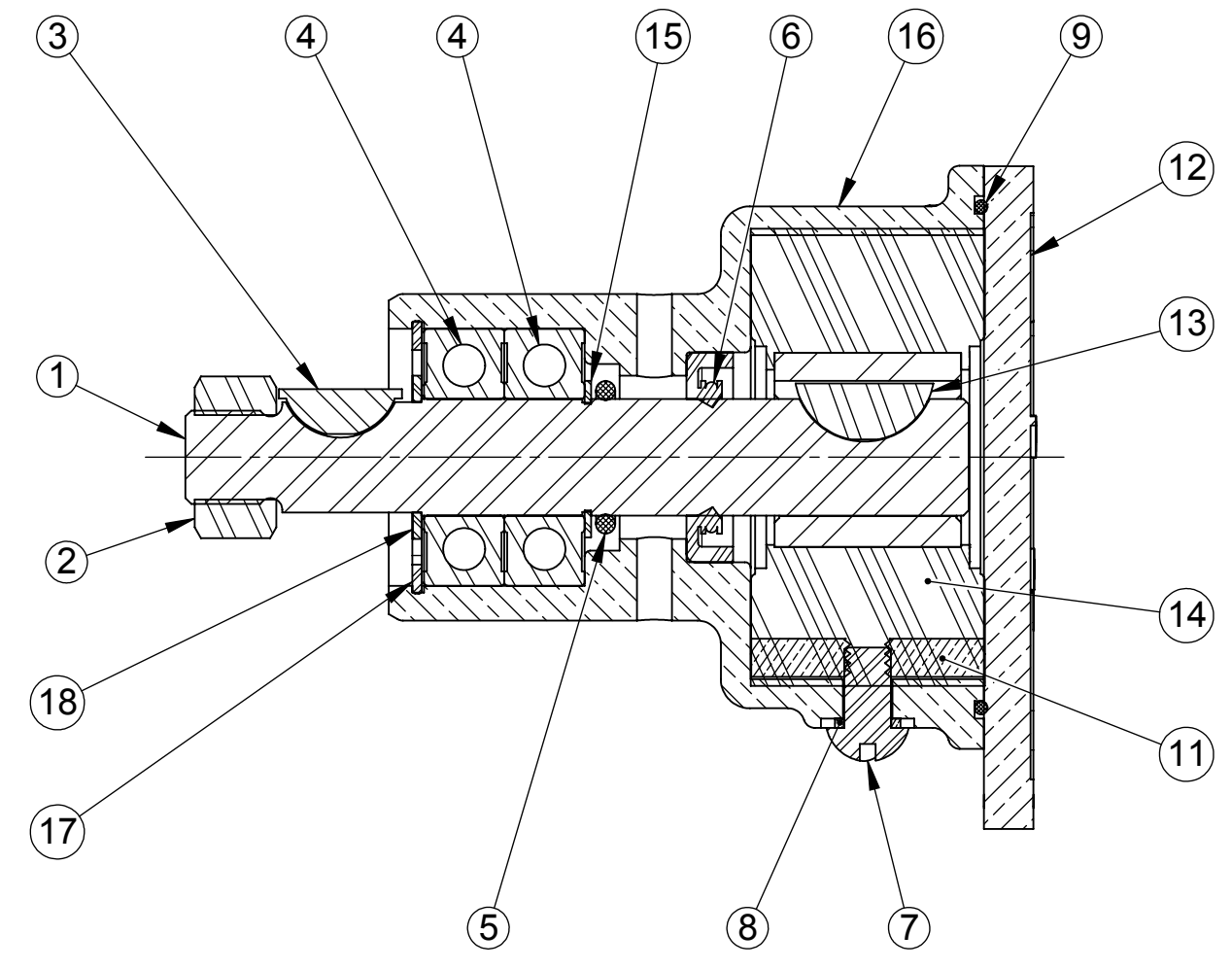

SECTION A-A

NOTES:

- ①. NOTE REMOVED. SEE ECN 7151
- 2. LIP SEAL TO BE INSTALLED DRY, ITEM 6.
- 3. USE COOLANT TO AID IN INSTALLATION OF RUBBER IMPELLER, ITEM 14.
- 4. PRESSURE TEST PUMP TO 20 - 30 PSI.
- 5. PULLEY TO BE FURNISHED AND ASSEMBLED TO PUMP BY CUSTOMER. CUSTOMER TO TORQUE HEX NUT, ITEM 2, TO 30 FT/LBS MAX. OVER-TORQUEING CAN DAMAGE RETAINING RING BEHIND BALL BEARING.

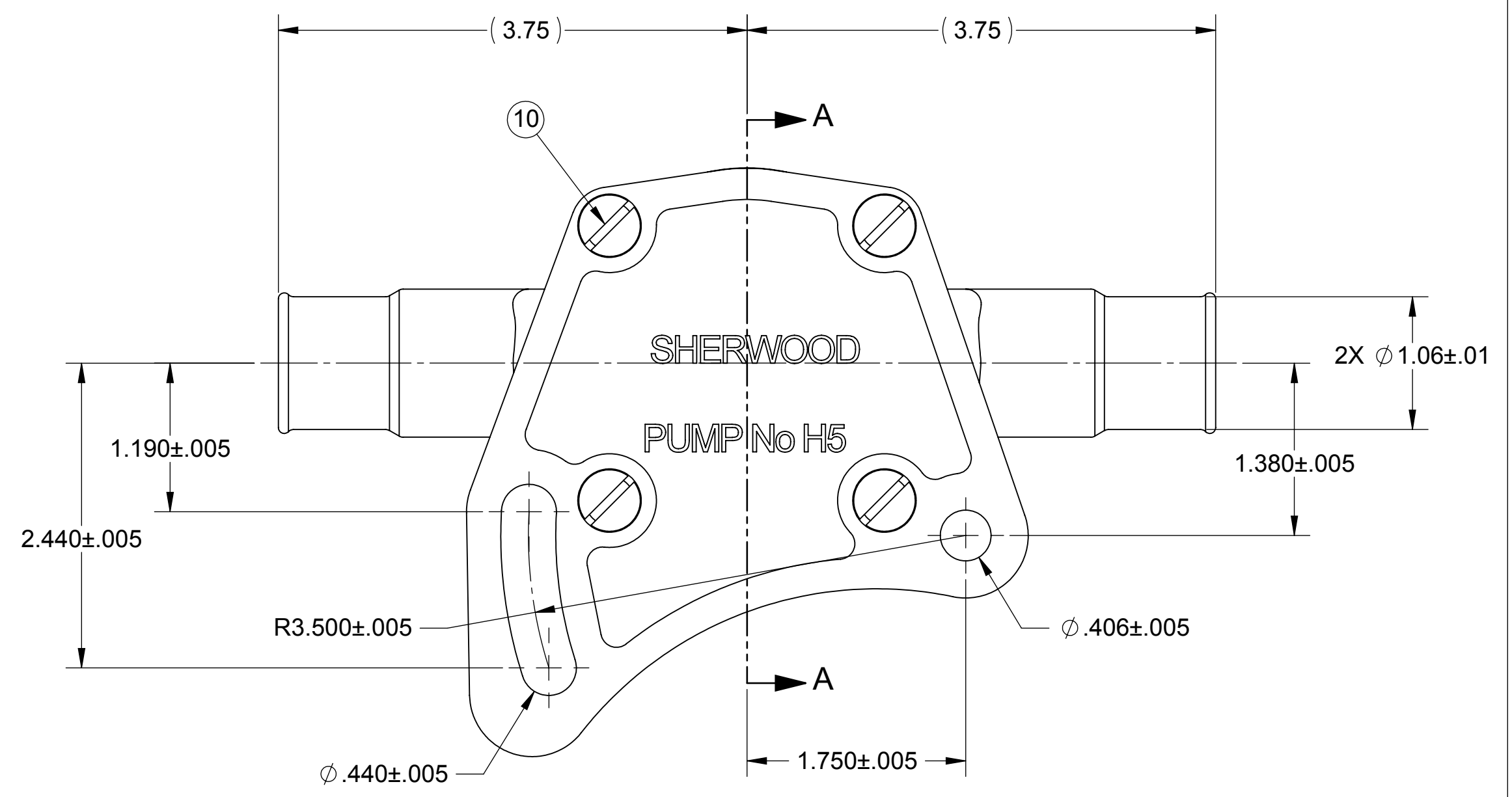
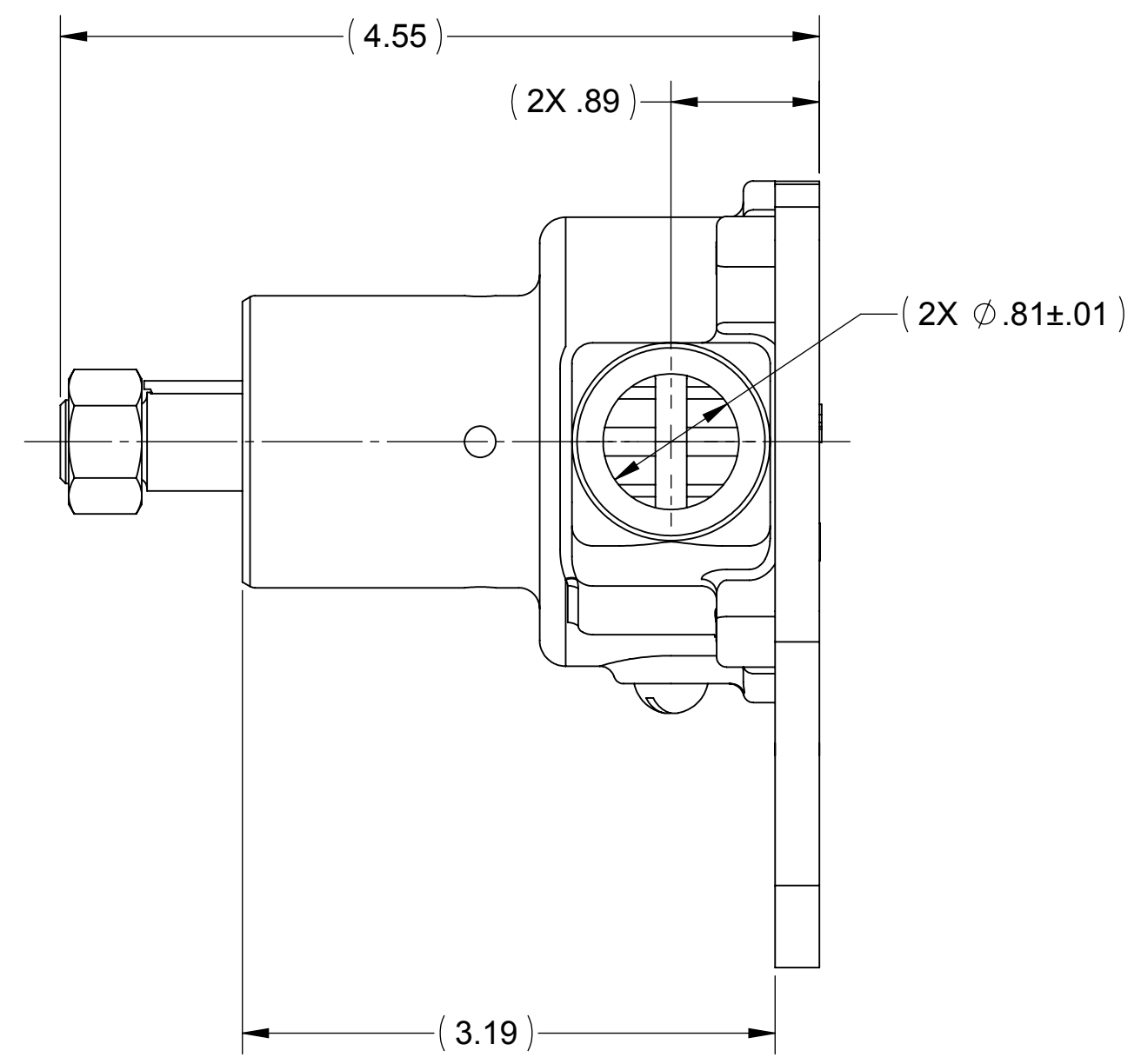

<p>SHERWOOD A Div. of Hypro Corporation A PENTAIR COMPANY 375 Fifth Avenue NW, New Brighton, MN 55112, (651) 766-6300</p>		REPLACES PART NO.	REV.
		DWG BY: RBM DATE: 6/21/1978	CHECKED BY: RBM DATE: 6/21/1978
DRAWING BASED ON ASME Y14.5M-1994		DO NOT SCALE PRINT	SIZE C
SCALE 1:1		SHEET NUMBER 1 OF 1	APPROVED BY: RBM DATE: 6/21/1978
THIRD ANGLE PROJECTION		THIS DRAWING IS THE PROPERTY OF HYPRO, AND WITHOUT WRITTEN AUTHORIZATION, MUST NOT BE COPIED OR COMMUNICATED	
PART DESCRIPTION		PART NUMBER	REV.
RUBBER IMPELLER PUMP ASSY		H5	S

REV.	ECN	REVISION DESCRIPTION	CHKD	DATE
S	7151	REMOVED NOTE 1	JJH	11/4/2008
R	6619	UPDATE BOM, REDRAWN ON NEW FORMAT	PEB	12/4/2007